

ERA Mining Machinery Limited 年代煤礦機電設備制造有限公司

(incorporated in the Cayman Islands with limited liability)

Stock Code: 8043



INTERIM
REPORT
2011

CHARACTERISTICS OF THE GROWTH ENTERPRISE MARKET (“GEM”) OF THE STOCK EXCHANGE OF HONG KONG LIMITED (THE “EXCHANGE”)

GEM has been established as a market designed to accommodate companies to which a high investment risk may be attached. In particular, companies may list on GEM with neither a track record of profitability nor any obligation to forecast future profitability. Furthermore, there may be risks arising out of the emerging nature of companies listed on GEM and the business sectors or countries in which the companies operate. Prospective investors should be aware of the potential risks of investing in such companies and should make the decision to invest only after due and careful consideration. The greater risk profile and other characteristics of GEM means that it is a market more suited to professional and other sophisticated investors.

Given the emerging nature of companies listed on GEM, there is a risk that securities traded on GEM may be more susceptible to high market volatility than securities traded on the Main Board and no assurance is given that there will be a liquid market in the securities traded on GEM.

The principal means of information dissemination on GEM is publication on the internet website operated by the Exchange. Listed companies are not generally required to issue paid announcements in gazetted newspapers. Accordingly, prospective investors should note that they need to have access to the GEM website in order to obtain up-to-date information on GEM-listed issuers.

Hong Kong Exchanges and Clearing Limited and The Exchange take no responsibility for the contents of this report, make no representation as to its accuracy or completeness and expressly disclaim any liability whatsoever for any loss howsoever arising from or in reliance upon the whole or any part of the content of this report.

This report, for which the directors (the “Directors”) of ERA Mining Machinery Limited (the “Company”) collectively and individually accept full responsibility, includes particulars given in compliance with the Rules Governing the Listing of Securities on GEM (the “GEM Listing Rules”) for the purpose of giving information with regard to the Company. The Directors, having made all reasonable enquiries, confirm that, to the best of their knowledge and belief:

- (1) the information contained in this report is accurate and complete in all material respects and not misleading;*
- (2) there are no other matters the omission of which would make any statement in this report misleading; and*
- (3) all opinions expressed in this report have been arrived at after due and careful consideration and are founded on bases and assumptions that are fair and reasonable.*

RESULTS

The Directors are pleased to announce the unaudited condensed consolidated results of the Company and its subsidiaries (together the “Group”) for the three months and six months ended 30 June 2011, together with the unaudited comparative figures for the corresponding periods in 2010 as follows:

CONDENSED CONSOLIDATED INCOME STATEMENT

For the three months and six months ended 30 June 2011

	<i>Note</i>	For the three months ended 30 June		For the six months ended 30 June	
		2011 (unaudited) <i>HK\$'000</i>	2010 (unaudited) (restated) <i>HK\$'000</i>	2011 (unaudited) <i>HK\$'000</i>	2010 (unaudited) (restated) <i>HK\$'000</i>
Turnover	3	513,336	323,992	787,204	422,452
Cost of goods sold		(436,509)	(274,636)	(653,792)	(360,258)
Gross profit		76,827	49,356	133,412	62,194
Other income		27,884	16,204	46,735	20,963
Selling and distribution costs		(30,535)	(25,877)	(50,053)	(41,863)
Administrative expenses		(28,679)	(15,231)	(57,262)	(39,079)
Other operating expenses		(141)	(1)	(307)	(7)
Profit from operations		45,356	24,451	72,525	2,208
Finance costs		(30,483)	(10,183)	(48,551)	(15,765)
Profit/(loss) before tax		14,873	14,268	23,974	(13,557)
Income tax expense	6	(2,680)	(6,119)	(3,124)	(1,977)
Profit/(loss) for the period attributable to owners of the Company	5	12,193	8,149	20,850	(15,534)
		<i>HK cents</i>	<i>HK cents</i>	<i>HK cents</i>	<i>HK cents</i>
Earnings/(loss) per share	7				
– basic		0.21	0.20	0.37	(0.39)
– diluted		0.21	N/A	0.37	N/A

CONDENSED CONSOLIDATED STATEMENT OF COMPREHENSIVE INCOME

For the three months and six months ended 30 June 2011

	For the three months ended 30 June		For the six months ended 30 June	
	2011	2010	2011	2010
	(unaudited)	(unaudited) (restated)	(unaudited)	(unaudited) (restated)
	<i>HK\$'000</i>	<i>HK\$'000</i>	<i>HK\$'000</i>	<i>HK\$'000</i>
Profit/(loss) for the period	12,193	8,149	20,850	(15,534)
Other comprehensive income:				
Exchange differences on translating foreign operations	14,863	-	21,249	-
Total comprehensive income/(loss) for the period attributable to owners of the Company	27,056	8,149	42,099	(15,534)



CONDENSED CONSOLIDATED STATEMENT OF FINANCIAL POSITION

As at 30 June 2011

		30 June 2011 (unaudited) <i>HK\$'000</i>	31 December 2010 (audited) <i>HK\$'000</i>
	<i>Note</i>		
Non-current assets			
Property, plant and equipment	8	414,015	345,264
Prepaid land lease payments		28,707	13,691
Goodwill		461,866	461,866
Intangible assets		11,817	6,965
		916,405	827,786
Current assets			
Inventories		311,369	202,014
Trade and other receivables	9	2,307,190	1,914,153
Prepaid land lease payments		679	364
Current tax assets		-	9
Pledged bank deposits		780,063	334,109
Bank and cash balances		62,795	102,664
		3,462,096	2,553,313
Current liabilities			
Trade and other payables	10	1,836,656	1,535,710
Borrowings	11	1,160,818	496,442
Provisions		5,801	5,670
Derivative component of convertible bond		-	23,967
Finance lease payables		31,131	22,189
Convertible bond		-	12,761
Amounts due to directors		85	99
Current tax liabilities		15,921	40,626
		3,050,412	2,137,464
Net current assets		411,684	415,849

		30 June 2011 (unaudited) HK\$ '000	31 December 2010 (audited) HK\$ '000
	<i>Note</i>		
Total assets less current liabilities		1,328,089	1,243,635
Non-current liabilities			
Finance lease payables		<u>17,935</u>	<u>21,310</u>
NET ASSETS		<u>1,310,154</u>	<u>1,222,325</u>
Capital and reserves			
Issued equity	<i>12</i>	<u>847,322</u>	<u>846,632</u>
Reserves		<u>462,832</u>	<u>375,693</u>
TOTAL EQUITY		<u>1,310,154</u>	<u>1,222,325</u>



CONDENSED CONSOLIDATED STATEMENT OF CHANGES IN EQUITY

For the six months ended 30 June 2011

	(Unaudited)					
	Attributable to owners of the Company					
	Issued equity <i>HK\$'000</i>	Share premium <i>HK\$'000</i>	Statutory reserve <i>HK\$'000</i>	Exchange reserve <i>HK\$'000</i>	Retained profits <i>HK\$'000</i>	Total equity <i>HK\$'000</i>
At 1 January 2011	846,632	-	60,782	32,578	282,333	1,222,325
Profit for the period	-	-	-	21,249	20,850	42,099
Issue of shares	191	7,449	-	-	-	7,640
Conversion of convertible bonds	499	37,591	-	-	-	38,090
At 30 June 2011	<u>847,322</u>	<u>45,040</u>	<u>60,782</u>	<u>53,827</u>	<u>303,183</u>	<u>1,310,154</u>

	(Unaudited) (restated)					
	Attributable to owners of the Company					
	Issued equity <i>HK\$'000</i>	Share premium <i>HK\$'000</i>	Statutory reserve <i>HK\$'000</i>	Exchange reserve <i>HK\$'000</i>	Retained profits <i>HK\$'000</i>	Total equity <i>HK\$'000</i>
At 1 January 2010	1	-	35,246	11,675	172,770	219,692
Loss for the period	-	-	-	-	(15,534)	(15,534)
At 30 June 2010	<u>1</u>	<u>-</u>	<u>35,246</u>	<u>11,675</u>	<u>157,236</u>	<u>204,158</u>

CONDENSED CONSOLIDATED STATEMENT OF CASH FLOWS

For the six months ended 30 June 2011

	For the six months ended 30 June	
	2011 (unaudited) <i>HK\$'000</i>	2010 (unaudited) (restated) <i>HK\$'000</i>
NET CASH (USED IN)/GENERATED FROM OPERATING ACTIVITIES	(176,479)	171,160
NET CASH USED IN INVESTING ACTIVITIES	(503,857)	(340,918)
NET CASH GENERATED FROM FINANCING ACTIVITIES	<u>634,812</u>	<u>221,277</u>
NET (DECREASE)/INCREASE IN CASH AND CASH EQUIVALENTS	(45,524)	51,519
Effect of foreign exchange rate changes	5,655	–
CASH AND CASH EQUIVALENTS AT BEGINNING OF PERIOD	<u>102,664</u>	<u>30,947</u>
CASH AND CASH EQUIVALENTS AT END OF PERIOD	<u><u>62,795</u></u>	<u><u>82,466</u></u>
ANALYSIS OF CASH AND CASH EQUIVALENTS, REPRESENTED BY		
Bank and cash balances	<u><u>62,795</u></u>	<u><u>82,466</u></u>

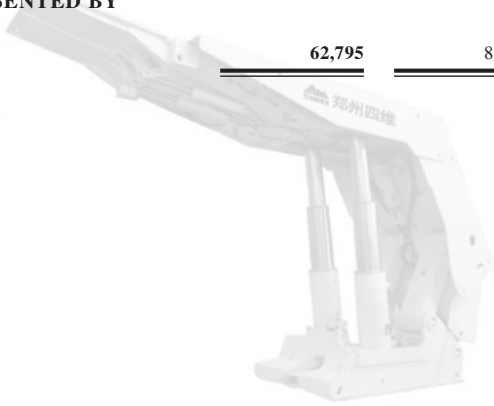

NOTES TO THE CONDENSED CONSOLIDATED FINANCIAL STATEMENTS

1. Basis of preparation

The condensed consolidated financial statements have been prepared in accordance with the applicable disclosure requirements of Chapter 18 of the Rules Governing the Listing of Securities on the Growth Enterprise Market of The Stock Exchange of Hong Kong Limited (the GEM Rules) and with Hong Kong Accounting Standard 34 (HKAS 34), Interim Financial Reporting.

The accounting policies adopted in preparing the unaudited consolidated results for the period under review are consistent with those followed in the Company's annual financial statements for the year ended 31 December 2010. The consolidated results for the six months ended 30 June 2011 are unaudited and have been reviewed by the audit committee of the Company.

The Group has not applied the new standards, amendments or interpretations which have been issued but are not yet effective. The Group has already commenced an assessment of their impact but is not yet in a position to state whether they would have a material impact on its results of operations and financial positions.

2. Adoption of new and revised Hong Kong Financial Reporting Standards

In the current period, the Group has applied, for the first time, a number of new or revised Standards and Interpretations ("new or revised HKFRSs") issued by the Hong Kong Institute of Certified Public Accountant ("HKICPA").

The Group has not applied the new or revised HKFRSs that have been issued but are not yet effective. The Group has already commenced an assessment of the impact of these new HKFRSs but is not yet in a position to state whether these new HKFRSs would have a material impact on its results of operations and financial position.

3. Turnover

Turnover which represents sales of mining machinery, related spare parts and consultancy services income for the six months ended 30 June 2010 and 2011 are as follows:

	For the six months ended 30 June	
	2011 (unaudited) <i>HK\$'000</i>	2010 (unaudited) (restated) <i>HK\$'000</i>
Sales of mining machinery	758,167	398,180
Sales of spare parts	28,808	24,272
Consultancy services income	229	–
	<u>787,204</u>	<u>422,452</u>

4. Segment information

The directors of the Company consider that the Group operates in a single reportable segment which is managed as a single strategic business unit that is engaged in the manufacturing and sale of coal mining machinery with similar technology and marketing strategy. The Group's operating profit or loss is earned or incurred within the People's Republic of China ("PRC") and all its operating assets are principally located in the PRC. Therefore, no business segment or geographical segment is presented.

5. Profit/(loss) for the period attributable to owners of the Company

The Group's profit/(loss) for the period attributable to owners of the Company is stated after charging:

	For the three months ended 30 June		For the six months ended 30 June	
	2011 (unaudited) <i>HK\$'000</i>	2010 (unaudited) (restated) <i>HK\$'000</i>	2011 (unaudited) <i>HK\$'000</i>	2010 (unaudited) (restated) <i>HK\$'000</i>
Amortisation of intangible assets (included in administrative expenses)	407	297	920	791
Cost of inventories sold	436,509	274,636	653,792	360,258
Depreciation	5,817	4,807	11,646	8,678
Operating lease charges				
– Amortisation of prepaid land lease payments	167	87	336	175
– Land and buildings rentals	286	212	917	831
Research and development expenditure	620	1,407	2,510	2,915
	<u>620</u>	<u>1,407</u>	<u>2,510</u>	<u>2,915</u>

6. Income tax expense

No provision for Hong Kong Profits Tax has been made for the periods as the Group did not generate any assessable profits arising in Hong Kong during the periods.

Under the Law of the PRC on Enterprise Income Tax (the “EIT Law”) and Implementation Regulation of the EIT Law, the tax rate of the PRC subsidiary, Zhengzhou Siwei Mechanical & Electrical Equipment Manufacturing Co., Ltd. (“Zhengzhou Siwei”), is 25% from 1 January 2008 onwards.

According to the new EIT law, entities that qualify as “High and New Technology Enterprises” are entitled to the preferential EIT rate of 15%. Zhengzhou Siwei received approval for the status as a “High and New Technology Enterprises”. The status is valid for three years starting from January 2008 and will be renewed after evaluation by relevant government authorities every three years. Zhengzhou Siwei is located in Zhengzhou High and New Technology Industries Development Zone, and was entitled to a PRC income tax rate of 15%. Zhengzhou Siwei is now in the process to renew its status.

7. Earnings/(loss) per share

The calculation of the basic and diluted earnings per share attributable to the ordinary equity holders of the Company is based on the following data:

	For the three months ended 30 June		For the six months ended 30 June	
	2011 (unaudited)	2010 (unaudited) (restated)	2011 (unaudited)	2010 (unaudited) (restated)
	HK\$'000	HK\$'000	HK\$'000	HK\$'000
Earnings				
Earnings for the purpose of basic and diluted earnings per share (Profit/(loss) for the period attributable to owners of the Company)	12,193	8,149	20,850	(15,534)
	'000	'000	'000	'000
Number of shares				
Weighted average number of ordinary shares for the purpose of basic earnings per share	5,683,450	4,000,000	5,681,758	4,000,000
Effect of share options	8,755	-	9,423	-
Weighted average number of ordinary shares for the purpose of diluted earnings per share	5,692,205	4,000,000	5,691,181	4,000,000

8. Property, plant and equipment

During the six months ended 30 June 2011, the Group acquired property, plant and equipment of HK\$34,306,000 (30 June 2010 (restated): HK\$15,459,000).

9. Trade and other receivables

Trade and other receivables include trade receivables of approximately HK\$1,786,806,000 (31 December 2010: HK\$1,577,266,000). The Group's trading terms with customers other than those for retention receivables are due on delivery. Deposit payments are normally required. The credit term for retention receivables is generally one year. The Group seeks to maintain strict control over its outstanding receivables. Overdue balances are reviewed regularly by the directors. The ageing analysis of trade receivables, based on the delivery date, and net of allowance, at the end of reporting period is as follows:

	30 June 2011 (unaudited) HK\$'000	31 December 2010 (audited) HK\$'000
0 – 90 days	533,122	914,651
91 – 180 days	183,208	210,320
181 – 365 days	749,574	160,715
Over 1 year	320,902	291,580
	<u>1,786,806</u>	<u>1,577,266</u>

As of 30 June 2011, trade receivables of approximately HK\$1,325,140,000 (31 December 2010: HK\$1,390,311,000) were past due but not impaired. These relate to a number of independent customers for whom there is no recent history of default. The ageing analysis of these trade receivables is as follows:

	30 June 2011 (unaudited) HK\$'000	31 December 2010 (audited) HK\$'000
0 – 90 days	416,316	770,736
91 – 180 days	106,080	192,743
181 – 365 days	547,159	143,086
Over 1 year	255,585	283,746
	<u>1,325,140</u>	<u>1,390,311</u>

10. Trade and other payables

Trade and other payables include trade payables and bills payables of approximately HK\$878,470,000 and HK\$820,089,000 respectively (31 December 2010: HK\$873,251,000 and HK\$451,728,000 respectively). The ageing analysis of trade payables, based on the date of receipt of goods, is as follows:

	30 June 2011 (unaudited) HK\$'000	31 December 2010 (audited) HK\$'000
0 – 90 days	313,304	539,346
91 – 180 days	242,746	96,787
181 – 365 days	273,826	102,421
Over 1 year	48,594	134,697
	878,470	873,251

11. Borrowings

	30 June 2011 (unaudited) HK\$'000	31 December 2010 (audited) HK\$'000
Short term bank loans, secured	1,160,818	496,042
Other loans	–	400
	1,160,818	496,442

The borrowings are repayable on demand or within one year.

12. Issued equity

Number of shares	Issued equity HK\$'000
5,683,974,395	847,322

Share capital of the Company

The movements in the share capital of the Company are as follows:

	Number of shares	Nominal value HK\$'000
Ordinary shares		
Authorised:		
Ordinary shares of HK\$0.01 each		
At 1 January 2010,		
31 December 2010 and		
30 June 2011	10,000,000,000	100,000
Issued and fully paid:		
Ordinary shares of HK\$0.01 each		
at 1 January 2011	5,614,942,395	56,149
Conversion of convertible bonds	49,932,000	499
Exercise of share options	19,100,000	191
At 30 June 2011	5,683,974,395	56,839



13. Contingent liabilities

Legal titles of certain land and buildings

The Group erected four buildings on certain parcels of land which the Group did not have relevant land use rights. Notwithstanding the local government authorities, including Planning Administration Bureau of Xingyang (滎陽市規劃管理局), Construction Administration Bureau of Xingyang (滎陽市建設管理局), Real Estate Administration Bureau of Xingyang (滎陽市房地產管理局) and Land Resources Bureau of Xingyang (滎陽市國土資源局), have issued certificates of confirmation in respect of the Group's right to use these buildings and parcels of land, the Group may subject to penalty for the breach of PRC laws and regulations. The directors do not consider a provision for liability be necessary on the grounds that there are no reliable estimate that can be made; and based on the above certificates of confirmation, the probability of penalty is low.

Financial guarantees issued

Pursuant to directors' meetings of Zhengzhou Siwei held on 18 August 2010 and 20 April 2011, the directors of Zhengzhou Siwei resolved to approve cross guarantee agreements from which Zhengzhou Siwei and two third parties mutually agreed to issue cross guarantee to the extent of approximately HK\$120,438,000 (31 December 2010: HK\$117,702,000) and HK\$156,570,000 (31 December 2010: HK\$153,013,000) respectively, to banks in respect of banking facilities granted to Zhengzhou Siwei and the third parties. Under such cross guarantees, Zhengzhou Siwei and the third parties are jointly and severally liable for all or any of each of their borrowings from the banks for one year.

At 30 June 2011, the directors of the Group do not consider it probable that a claim will be made against Zhengzhou Siwei under the above guarantees as the default risk is low. The maximum liability of Zhengzhou Siwei as at 30 June 2011 under the guarantees is the amount of bank loans drawn under the cross guarantees by the third parties at that date of approximately HK\$144,526,000.

INTERIM DIVIDEND

The Directors do not recommend the payment of any interim dividend for the six months ended 30 June 2011 (for the six months ended 30 June 2010: Nil)

CHAIRMAN'S STATEMENT

To Stakeholders:

On behalf of the Board of Directors and management of ERA, we thank you for the opportunity to share with you ERA's results from the first half of 2011.

Once again, we recorded significant year-on-year progress on our major goals, including:

- 86.3%, 6.3% and 580% increases in turnover, net profit and EBITDA respectively;

Our order book at the end of June 2011 was strong, at approximately HK\$1.1 billion, 20% higher than it was one year earlier.

- improved operating efficiencies due to the substantial completion of our newly consolidated manufacturing facilities in Zhengzhou, and decreases in SG&A expenses as a percent of sales;
- Three joint ventures with:
 - Marco Systemanalyse und Entwicklung GmbH to develop and manufacture electro-hydraulic control systems, placing us at the forefront of the coming wave of automation in China's coal mining industry;
 - Zhengzhou Xinxing Metal Surface Engineering Co., Ltd. to build our aftermarket sales for rebuilt hydraulic cylinders; and
 - a joint venture with new customer Xishan Coal Electricity Group, an affiliate of Shanxi Coking Coal Group, China's 4th largest coal mining company.

We believe 2011 will continue to be a year of significant continued growth and accomplishment, and for this we once again thank our investors who have made this possible.

Respectfully,
Emory Williams
Chairman

10 August 2011

MANAGEMENT DISCUSSION AND ANALYSIS

Business Overview

Products

At present, the sole products of the Group's principal subsidiary, Zhengzhou Siwei Mechanical & Electrical Equipment Manufacturing Co., Ltd ("Zhengzhou Siwei") are hydraulic roof supports ("shields") and related equipments for the underground coal mining industry. Zhengzhou Siwei designs and manufactures a full range of shields ranging from 0.8 m to 7.3 m in height and from 1,800 KN to 18,000 KN in terms of working resistance. All shields delivered are custom manufactured to the mining requirements of each customer.

Expansion of Manufacturing Capabilities and Capacity

Zhengzhou Siwei has been constantly expanding its manufacturing capacity and capabilities. During the first half of 2011, most of this expansion has occurred in Zhengzhou Siwei's newest Guangwu factory location in Zhengzhou, where Zhengzhou Siwei is consolidating all of its shield manufacturing. Significant additions to manufacturing capacity have been made across the board, especially in advanced electro-plating, welding and machining.

Market Overview

China's ever increasing demand for highly mechanized coal mining equipment has been driven principally by two factors, China's increasing demand for electricity and China's government policy directed at improving the safety and efficiency of Chinese mining. These government policies are reflected in the consolidation of the small and medium sized coal mines and the mandating of increasingly rigorous safety measures. While growth of new mines may slow during China's 12th Five Year Plan, management expects this development to intensify the trend of comprehensive mechanization in China's existing and newly consolidated mines. The management expects these factors to continue to result in continued strong short and mid-term growth for China's mining machinery market.

Approximately 97% of the China's coal mines are located underground below 400 meters. Over 55% of the capital expenditure spending at the working phase of the underground coal mining is attributable to by shields, and the balance represents the sum of armored face conveyors, shearers and roadheaders.

Prospects

Indicators point to continued strong economic growth in China. Continued initiatives by China's central government strengthening policies aimed at improving mine safety, efficiency and mitigating environmental impact, requiring mine mechanization and further consolidation of small and medium sized coal mines also bode well for the coal mining industry. ERA has continuously spent the first half of 2011 building the foundations for future growth. Heavy investment in new, efficient manufacturing facilities, in human resources, in improved manufacturing and new products give the board and management reason to believe that they can achieve significant sales growth while improving profitability.

Financial Review

Turnover

China's continued strong economic growth, demand for energy and government policies encouraging coal mine mechanization helped the Group to achieve record sales and earnings. For the six months ended 30 June 2011, the Group recorded a turnover of approximately HK\$787.2 million, represents a growth of 86.3% when compared to the same period last year.

The Group's sales are typically highly seasonal, with a majority of turnover occurring in the second half of the year.

Cost of Sales

For the six months ended 30 June 2011, cost of sales was approximately HK\$653.8 million or 83.1% of turnover compared to HK\$360.3 million or 85.3% of turnover in 2010.

Gross Profit and Gross Margin

The Group's gross profit for the six months ended 30 June 2011 was HK\$133.4 million, 114.5% higher in comparison to the same period last year. Gross profit margin increased to 16.9% from 14.7%, with margin increases primarily attributable to increases in average selling prices due to the sale of larger units and new patented products.

Selling and Distribution Costs

For the six months ended 30 June 2011, the Group incurred selling and distribution costs of approximately HK\$50.1 million, an increase of approximately HK\$8.2 million or 19.6% when compared to the same period last year. Increase were primarily attributable to higher turnover volume. The selling and distribution costs in percentage to turnover decreased from 10% to 6%.

Administrative Expenses

For the six months ended 30 June 2011, the Group incurred administrative expenses of approximately HK\$57.3 million, an increase of approximately HK\$18.2 million or 46.5% when compared to the same period last year. The increase in administrative expenses was principally due to additional salary and benefits, finance lease charges on leased equipments and professional fee. The administrative expenses in percentage to turnover decreased from 9% to 7%.

Finance Costs

For the six months ended 30 June 2011, the Group incurred finance costs of approximately HK\$48.6 million, an increase of approximately HK\$32.8 million or 208.0% when compared to the same period last year. Additional finance costs incurred for the current reporting period represent charges on short term bank borrowings (for working capital and capacity expansion) and interests on bills.

Net Profit Attributable to Owners of the Company

For the six months ended 30 June 2011, the Group's net profit attributable to owners of the Company was approximately HK\$20.9 million.

EBITDA

Given the Group's increased financial costs due to continued growth in fixed assets and working capital needs, the management team believes EBITDA (a non HKFRS accounting standard metric comprised of net profit before income tax, net finance costs, depreciation and amortization) is a good metric for assessing at the Group's results. EBITDA for the six months ended 30 June 2011 was approximately HK\$85.4 million.

	For the six months ended 30 June		
	2011	2010	Variance in
	(unaudited)	(unaudited)	%
	HK\$'000	(restated) HK\$'000	
Profit/(loss) before tax	23,974	(13,557)	N/A
Depreciation & amortization	12,902	9,644	33.8
Net finance costs	48,551	15,765	208.0
EBITDA	85,427	11,852	620.8

Liquidity and Financial Resources

Borrowings and banking facilities

As at 30 June 2011, the Company had bank loans, finance lease payables and a 6-month redeemable fixed coupon promissory note of approximately HK\$910,818,000, HK\$49,066,000 and HK\$250,000,000 respectively.

Foreign exchange exposure

Transactions of the Group were mainly denominated either in Hong Kong dollars, United States dollars and Renminbi. In view of the stability of the exchange rate between these currencies, the Directors do not consider that the Group was significantly exposed to foreign exchange risk.

Capital structure

As at 30 June 2011, the Group uses a combination of cash generated from operations and bank loans to meet our financial obligations. Total net assets were approximately HK\$1,310.2 million as at 30 June 2011, representing an increase of approximately 7.2% over that of 31 December 2010.

Employee information

As at 30 June 2011, the Group had a total of 3,342 employees. The total staff costs, including directors' emoluments, amounted to approximately HK\$74.9 million for the period under review.

Save as disclosed hereof, no information in relation to the Group's performance has changed materially from the information disclosed in the Company's 2010 annual report.



DIRECTORS' AND CHIEF EXECUTIVES' INTERESTS AND SHORT POSITIONS IN SHARES, UNDERLYING SHARES AND DEBENTURES

As at 30 June 2011, the interests of the Directors and the chief executives of the Company in shares, underlying shares or debentures of the Company or any of its associated corporations (within the meaning of Part XV of the Securities and Futures Ordinance (Chapter 571 of the laws of Hong Kong) (the "SFO")) which would have to be notified to the Company and the Exchange pursuant to the provisions of Divisions 7 and 8 of Part XV of the SFO (including interests and/or short positions of which they were taken or deemed to have taken under such provisions of the SFO) and/or required to be entered in the register maintained by the Company pursuant to Section 352 of the SFO or which had to be notified to the Company and the Exchange pursuant to Rules 5.46 to 5.68 of the GEM Listing Rules relating to securities transactions by the Directors were as follows:

Interests in shares of the Company

Name of Directors	Capacity	Number and class of shares held	Approximate percentage of issued share capital
Mr. Emory Williams	Corporate Interest (Note 1)	2,667,597,312 ordinary shares (long position)	46.93%
Mr. Lee Jong Dae	Corporate Interest (Note 2)	20,000,000 ordinary shares (long position)	0.35%
Mr. Christopher John Parker	Corporate Interest (Note 3)	20,148,000 ordinary shares (long position)	0.35%

Notes:

1. Out of the total 2,667,597,312 ordinary shares, 2,617,507,028 ordinary shares in the Company owned by Mr. Emory Williams are beneficially owned by and registered in the name of Mining Machinery Ltd. Mr. Emory Williams has 32.25% equity interests in Mining Machinery Ltd. And 20,500,000 ordinary shares in the Company owned by Mr. Emory Williams are beneficially owned by and registered in the name of Power Castle Development Limited. Madam Liu Jie, the spouse of Mr. Emory Williams, beneficially owns 15,402,284 ordinary shares in the Company.
2. The 20,000,000 ordinary shares in the Company owned by Mr. Lee Jong Dae are beneficially owned by and registered in the name of Wah Hong Investment Limited.
3. The 20,148,000 ordinary shares in the Company owned by Mr. Christopher John Parker are beneficially owned by and registered in the name of Clydesdale International Ltd.

Long positions in underlying shares of equity derivatives of the Company

Name of Directors	Capacity	Description of equity derivatives (number and class of underlying shares)	Approximate percentage of issued share capital
Mr. Li Rubo	Beneficial owner	share options to subscribe for shares (3,200,000 ordinary shares) (<i>Note</i>)	0.06%
Mr. Lee Jong Dae	Beneficial owner	share options to subscribe for shares (3,800,000 ordinary shares) (<i>Note</i>)	0.07%
Mr. David Marc Boulanger	Beneficial owner	share options to subscribe for shares (900,000 ordinary shares) (<i>Note</i>)	0.02%
Mr. Christopher John Parker	Beneficial owner	share options to subscribe for shares (900,000 ordinary shares) (<i>Note</i>)	0.02%
Mr. Chan Sze Hon	Beneficial owner	share options to subscribe for shares (300,000 ordinary shares) (<i>Note</i>)	0.01%

Note: The aforesaid share options are classified as “long position” under the SFO. For details of the share options granted, please refer to the section headed “Share Option Scheme” below.

Save as disclosed above, as at 30 June 2011, none of the Directors nor the chief executive of the Company had any interests or short positions in any shares, underlying shares or debentures of the Company or any associated corporations (within the meaning of Part XV of the SFO) which would have to be notified to the Company and the Exchange pursuant to the provisions of Divisions 7 and 8 of Part XV of the SFO (including interests and/or short positions which they were taken or deemed to have taken under such provisions of the SFO), or which were required, pursuant to Section 352 of the SFO, to be entered in the register referred to therein, or which were required, pursuant to Rules 5.48 to 5.67 of the GEM Listing Rules, to be notified to the Company and the Exchange.

SHARE OPTION SCHEME

The following table discloses details of options outstanding under the Company's share option scheme (the "Share Option Scheme") adopted by the Company on 5 June 2001.

Name of grantee	Date of grant	Outstanding as at 1 January 2011	Number of shares options			Outstanding as at 30 June 2011
			Exercised	Granted	Lapsed	
Directors						
Mr. Emory Williams	10 July 2008	3,200,000	(3,200,000)	-	-	-
Mr. Li Rubo	10 July 2008	3,200,000	-	-	-	3,200,000
Mr. Lee Jong Dae	10 July 2008	3,800,000	-	-	-	3,800,000
Mr. David Marc Boulanger	10 July 2008	900,000	-	-	-	900,000
Mr. Christopher John Parker	10 July 2008	900,000	-	-	-	900,000
Mr. Chan Sze Hon	10 July 2008	300,000	-	-	-	300,000
Mr. Lee Sung Min <i>(resigned on 13 October 2010)</i>	10 July 2008	900,000	(900,000)	-	-	-
Mr. Kim Beom Soo <i>(resigned on 13 October 2010)</i>	10 July 2008	900,000	(900,000)	-	-	-
			<hr/>	<hr/>	<hr/>	<hr/>
		14,100,000	(5,000,000)	-	-	9,100,000
			<hr/>	<hr/>	<hr/>	<hr/>
Employees in aggregate	10 July 2008	4,900,000	-	-	-	4,900,000
Advisors and Consultants	10 July 2008	19,400,000	(13,200,000)	-	-	6,200,000
			<hr/>	<hr/>	<hr/>	<hr/>
Total		38,400,000	(18,200,000)	-	-	20,200,000
			<hr/> <hr/>	<hr/> <hr/>	<hr/> <hr/>	<hr/> <hr/>

The share options were granted on 10 July 2008 at the exercise price of HK\$0.40 per share with exercisable period from 10 July 2009 to 9 July 2013.

Mr. Lee Sung Min and Kim Beom Soo resigned as directors of the Company on 13 October 2010, according to the Share Option Scheme, Mr. Lee Sung Min and Mr. Kim Beom Soo are eligible to exercise the option within three months after resignation.

Details of the Share Option Scheme are set out in the Company's 2010 annual report.

SUBSTANTIAL SHAREHOLDERS' AND OTHER PERSON'S INTERESTS AND SHORT POSITIONS IN SHARES AND UNDERLYING SHARES AND DEBENTURES

As at 30 June 2011, so far as is known to the Directors, the following persons (not being a Director or a chief executive of the Company) had an interest and/or a short position in the shares and/or underlying shares of the Company which would fall to be disclosed to the Company and the Exchange pursuant to the provisions of Divisions 2 and 3 of Part XV of the SFO and/or required to be entered in the register maintained by the Company pursuant to Section 336 of the SFO and/or were directly or indirectly interested in 10% or more of the nominal value of any class of share capital carrying rights to vote in all circumstances at general meetings of any members of the Group.

Name of substantial shareholder	Capacity	Number and class of shares held	Approximate percentage of issued share capital
Mining Machinery Ltd.	Beneficial owner	2,617,507,028 ordinary shares (long position) (Note)	46.1%

Note: Mr. Emory Williams and Mr. James Edward Thompson III have 32.25% and 67.25% equity interests, respectively, in Mining Machinery Ltd. Mr. Emory Williams is the chairman and an executive Director of the Company.

Save as disclosed above, as at 30 June 2011, there was no person who had an interest and/or a short position in the shares and/or underlying shares of the Company which would fall to be disclosed to the Company and the Exchange under the provisions of Divisions 2 and 3 of Part XV of the SFO and/or required to be entered in the register maintained by the Company pursuant to Section 336 of the SFO and/or was directly or indirectly interested in 10% or more of the nominal value of any class of share capital carrying rights to vote in all circumstances at general meetings of any members of the Group, or any options in respect of such capital.

PURCHASE, REDEMPTION AND SALE OF THE COMPANY'S LISTED SECURITIES

Neither the Company nor any of its subsidiaries has purchased, redeemed or sold any of the Company's listed securities during the period under review.

COMPETING INTEREST

As at 30 June 2011, the Directors are not aware of any business or interest of each Director, initial management shareholder and their respective associates (as defined in the GEM Listing Rules) that competes or may compete with the business of the Group and any other conflicts of interest which any such person has or may have with the Group.

AUDIT COMMITTEE

As required by the GEM Listing Rules, the Company has established an audit committee (the "Audit Committee") with written terms of reference which deal clearly with its authority and duties. Its principal duties are to review and supervise the Group's financial reporting process and internal control systems. The Audit Committee comprises three independent non-executive Directors, Mr. Chan Sze Hon, Mr. David Marc Boulanger and Mr. Christopher John Parker. The Group's unaudited results for the six months ended 30 June 2011 have been reviewed by the Audit Committee, which was of the opinion that the preparation of such results complied with the applicable accounting standards, the GEM Listing Rules and legal requirements, and that adequate disclosures have been made.

COMPLIANCE WITH RULES 5.48 TO 5.67 OF THE GEM LISTING RULES

The Company has adopted a code of conduct regarding Directors' securities transactions on terms no less exacting than the required standard of dealings as set out in Rules 5.48 to 5.67 of the GEM Listing Rules throughout the period under review. Having made specific enquiry, the Directors have confirmed that they have complied with such code of conduct and required standard of dealings throughout the period under review.

COMPLIANCE WITH CODE ON CORPORATE GOVERNANCE PRACTICES

The Company has established a formal and transparent procedure to protect the interests of the shareholders of the Company. The Company applied the principles and complied with all the code provisions as set out in the Code on Corporate Governance Practices contained in Appendix 15 of the GEM Listing Rules throughout the year under review.

By Order of the Board
ERA Mining Machinery Limited
Emory Williams
Chairman

Hong Kong, 10 August 2011

As at the date of this report, the executive directors are Mr. Emory WILLIAMS, Mr. LEE Jong-Dae, Mr. LI Rubo, Mr. WANG Fu and Dr. Phil Qiu JIN; and the independent non-executive directors are Mr. BOULANGER David Marc, Mr. PARKER Christopher John, Mr. CHAN Sze Hon, Mr. DONG Xiangge and Mr. JIANG Ming.