

# MOBI 摩比

MOBI Development Co., Ltd.  
摩比發展有限公司

(Incorporated in the Cayman Islands with limited liability)

Stock code: 947



## GLOBAL OFFERING

Global Coordinator, Lead Manager  
and Joint Bookrunner

Piper Jaffray

Joint Sponsor

Joint Bookrunner, Joint Sponsor  
and Co-Lead Manager

Piper Jaffray



---

## IMPORTANT

---

*If you are in any doubt about any of the contents to this prospectus, you should obtain independent professional advice.*

# MOBI 摩比

## MOBI Development Co., Ltd.

### 摩比發展有限公司

*(incorporated in the Cayman Islands with limited liability)*

### GLOBAL OFFERING

**Number of Offer Shares : 175,515,000 Shares (subject to the Over-allotment Option)**

**Number of Hong Kong Offer Shares : 17,552,000 New Shares (subject to adjustment)**

**Number of International Placing Shares : 157,963,000 New Shares (subject to adjustment and the Over-allotment Option)**

**Maximum Offer Price : HK\$3.50 per Offer Share (payable in full in Hong Kong dollars on application plus brokerage of 1%, SFC transaction levy of 0.004% and Stock Exchange trading fee of 0.005% and subject to refund)**

**Nominal value : US\$0.000001 per Share**

**Stock code : 947**

*Global Coordinator, Lead Manager and Joint Bookrunner*

# Piper Jaffray

*Joint Sponsor*

*Joint Bookrunner, Joint Sponsor and Co-Lead Manager*

## Piper Jaffray



---

The Hong Kong Exchanges and Clearing Limited, The Stock Exchange of Hong Kong Limited and Hong Kong Securities Clearing Company Limited take no responsibility for the contents to this prospectus, make no representation as to its accuracy or completeness and expressly disclaim any liability whatsoever for any loss howsoever arising from or in reliance upon the whole or any part of the contents to this prospectus.

A copy of this prospectus, having attached thereto the documents specified in the section headed "Documents delivered to the Registrar of Companies" in Appendix VII to this prospectus, has been registered by the Registrar of Companies in Hong Kong as required by Section 342C of the Companies Ordinance (Chapter 32 of the Laws of Hong Kong). The Securities and Futures Commission of Hong Kong and the Registrar of Companies in Hong Kong take no responsibility as to the contents to this prospectus or any other documents referred to above.

We expect to determine the Offer Price by agreement with the Global Coordinator (on behalf of the Hong Kong Underwriters) on the Price Determination Date. The Price Determination Date is expected to be on or around December 10, 2009 and, in any event, not later than December 12, 2009. The Offer Price will be not more than HK\$3.50, unless otherwise announced. Applicants for the Offer Shares are required to pay, on application, the maximum Offer Price of HK\$3.50 for each Hong Kong Offer Share together with 1.0% brokerage, 0.004% SFC transaction levy and 0.005% Stock Exchange trading fee subject to refund if the Offer Price as finally determined should be lower than HK\$3.50.

The Global Coordinator (on behalf of the Underwriters, and with our consent) may reduce the number of Offer Shares being offered under the Global Offering and/or the indicative offer price range that is stated in this prospectus (which is HK\$2.72 to HK\$3.50 per Share) at any time prior to the morning of the last day for the lodging of applications under the Hong Kong Public Offering. In such a case, notices of the reduction in the number of Offer Shares and/or the indicative offer price range will be published in the South China Morning Post (in English) and the Hong Kong Economic Times (in Chinese) and on the website of the Stock Exchange ([www.hkex.com.hk](http://www.hkex.com.hk)) and the website of the Company ([www.mobi-antenna.com](http://www.mobi-antenna.com)) not later than the morning of the day which is the last day for lodging applications under the Hong Kong Public Offering. Further details are set out in the sections headed "Structure of the Global Offering" and "How to apply for Hong Kong Offer Shares". If, for whatever reason, we and the Global Coordinator are not able to agree on the Offer Price, the Global Offering will not proceed and will lapse.

Pursuant to the force majeure provisions contained in the Hong Kong Underwriting Agreement, the Global Coordinator (on behalf of the Hong Kong Underwriters) has the right in certain circumstances, in its sole and absolute discretion, to terminate the obligations of the Hong Kong Underwriters pursuant to the Hong Kong Underwriting Agreement at any time prior to 8:00 a.m. (Hong Kong time) on the Listing Date (such first dealing date is currently expected to be December 17, 2009). Further details of the terms of the force majeure provisions are set out in the paragraph headed "Grounds for termination" under the section headed "Underwriting" in this prospectus.

The Offer Shares have not been and will not be registered under the U.S. Securities Act and may not be offered, sold, pledged or transferred within the United States or to, or for the account or benefit of U.S. persons, unless the Offer Shares are registered under the U.S. Securities Act, or an exemption from the registration requirements of the U.S. Securities Act is available. The Offer Shares are being offered, sold or delivered to non-U.S. persons outside the United States in offshore transactions pursuant to Regulation S.

December 4, 2009

---

## EXPECTED TIMETABLE<sup>(1)</sup>

---

Application lists open <sup>(2)</sup> .....	11:45 a.m. on December 9, 2009
Latest time for lodging <b>WHITE</b> and <b>YELLOW</b> Application Forms and giving <b>electronic application</b> instructions to HKSCC <sup>(3)</sup> .....	12:00 noon on December 9, 2009
Latest time to complete electronic applications under <b>White Form eIPO</b> service through the designated website <b><u>www.eipo.com.hk</u></b> <sup>(4)</sup> .....	11:30 a.m. on December 9, 2009
Latest time to complete payment of <b>White Form eIPO</b> applications by effecting internet banking transfer(s) or PPS payment transfer(s) .....	12:00 noon on December 9, 2009
Application lists close <sup>(2)</sup> .....	12:00 noon on December 9, 2009
Expected Price Determination Date <sup>(5)</sup> .....	December 10, 2009
(1): Announcement of the Offer Price and the indication of the levels of interest in the International Placing, the level of applications in respect of the Hong Kong Public Offering and the basis of allotment of the Hong Kong Offer Shares to be published in the South China Morning Post (in English) and the Hong Kong Economic Times (in Chinese) on or before .....	December 16, 2009
(2): Results of allocation in the Hong Kong Public Offering (with successful applicants' identification document numbers, where applicable) will be available through a variety of channels as described in the section headed "How to apply for Hong Kong Offer Shares" from .....	December 16, 2009
(3): A full announcement of the Hong Kong Public Offering containing (1) and (2) above will be published on the website of the Hong Kong Stock Exchange at <b><u>www.hkex.com.hk</u></b> and our Company's website at <b><u>www.mobi-antenna.com</u></b> from .....	December 16, 2009
Results of allocations in the Hong Kong Public Offering will be available at <b><u>www.iporesults.com.hk</u></b> with a "search by ID" function .....	December 16, 2009
Dispatch of share certificates in respect of wholly or partially successful applications on or before <sup>(6)</sup> .....	December 16, 2009
Dispatch of White Form e-Refund payment instructions or refund checks in respect of wholly successful (if applicable) or wholly or partially unsuccessful applications on or before <sup>(7)</sup> .....	December 16, 2009
Dealings in Shares on the Stock Exchange to commence on .....	9:30 a.m. on December 17, 2009

*Notes:*

- (1) All times refer to Hong Kong local time. Details of the structure of the Global Offering, including its conditions, are set out in the section headed "Structure of the Global Offering" in this prospectus.
- (2) If there is a "black" rainstorm warning or a tropical cyclone warning signal number eight or above in force in Hong Kong at any time between 9:00 a.m. and 12:00 noon on December 9, 2009, the application lists will not open and close on that

---

## EXPECTED TIMETABLE<sup>(1)</sup>

---

day. Further information is set out in the paragraph headed “Effect of bad weather on the opening of the application lists” under the section headed “How to apply for Hong Kong Offer Shares” in this prospectus. If the application lists do not open and close on December 9, 2009, the dates mentioned in this section headed “Expected Timetable” may be affected. An announcement will be made by our Company in such event.

- (3) Applicants who apply by giving **electronic application** instructions to the HKSCC should refer to the paragraph headed “If you apply by giving **electronic application** instruction to HKSCC” under the section headed “How to apply for Hong Kong Offer Shares” in this prospectus.
- (4) You will not be permitted to submit your application through the designated website at [www.eipo.com.hk](http://www.eipo.com.hk) after 11:30 a.m. on the last day for submitting applications. If you have already submitted your application and obtained an application reference number from the designated website prior to 11:30 a.m., you will be permitted to continue the application process (by completing payment of application monies) until 12:00 noon on the last day for submitting applications, when the application lists close.
- (5) We expect to determine the Offer Price by agreement with the Global Coordinator on behalf of the Hong Kong Underwriters on the Price Determination Date. The Price Determination Date is expected to be on or around December 10, 2009 and, in any event, not later than December 12, 2009.
- (6) Share certificates for the Hong Kong Offer Shares are expected to be issued on December 16, 2009 but will only become valid certificates of title provided that (i) the Global Offering has become unconditional in all respects, and (ii) the right of termination as described in the paragraph headed “Grounds for termination” under the section headed “Underwriting” in this prospectus has not been exercised and has lapsed.
- (7) e-Refund payment instruction or refund checks will be issued in respect of wholly or partially unsuccessful applications and in respect of successful applications if the Offer Price is less than the price payable on application. Part of the applicant’s Hong Kong identity card number or passport number, or, if the application is made by joint applicants, part of the Hong Kong identity card number or passport number of the first-named applicant, provided by the applicant(s) may be printed on the refund check, if any. Such data would also be transferred to a third party for refund purpose. Banks may require verification of an applicant’s Hong Kong identity card number or passport number before cashing the refund check. Inaccurate completion of an applicant’s Hong Kong identity card number or passport number may lead to delay in encashment of or may invalidate the refund check.

Applicants who apply on **WHITE** Application Forms for 1,000,000 Shares or more under the Hong Kong Public Offering and have indicated in their Application Forms that they wish to collect refund checks (where applicable) and (where applicable) share certificates in person from our Company’s Hong Kong Share Registrar may collect refund checks (where applicable) and (where applicable) share certificates in person from our Company’s Hong Kong Share Registrar, Computershare Hong Kong Investor Services Limited at Shops 1712-1716, 17th Floor, Hopewell Centre, 183 Queen’s Road East, Wanchai, Hong Kong, from 9:00 a.m. to 1:00 p.m. on December 16, 2009. Identification and (where applicable) authorization documents acceptable to Computershare Hong Kong Investor Services Limited must be produced at the time of collection.

Applicants who apply via the **White Form eIPO** service by submitting an electronic application to the designated White Form eIPO Service Provider through the designated website at [www.eipo.com.hk](http://www.eipo.com.hk) for 1,000,000 Shares or more under the Hong Kong Public Offering, may collect share certificates (where applicable) in person from Computershare Hong Kong Investor Services Limited at Shops 1712-1716, 17th Floor, Hopewell Centre, 183 Queen’s Road East, Wanchai, Hong Kong, from 9:00 a.m. to 1:00 p.m. on December 16, 2009. Identification and (where applicable) authorization documents acceptable to Computershare Hong Kong Investor Services Limited must be produced at the time of collection. Applicants who apply via the **White Form eIPO** service by paying the application monies through a single bank account, e-Refund payment instructions (if any) will be despatched to their application payment bank account on or around December 16, 2009. Applicants who apply via the **White Form eIPO** service by paying the application monies through multiple bank accounts, refund check(s) will be despatched to the address specified in their **White Form eIPO** application on or around December 16, 2009, by ordinary post and at their own risk.

Applicants who apply on **YELLOW** Application Forms for 1,000,000 Shares or more under the Hong Kong Public Offering and have indicated in their Application Forms that they wish to collect refund checks in person may collect their refund checks (if any) but may not elect to collect their share certificates, which will be deposited into CCASS for credit to their designated CCASS Participants’ stock accounts or CCASS Investor Participant stock accounts, as appropriate. The procedure for collection of refund checks for applicants who apply on **YELLOW** Application Forms for Shares is the same as that for **WHITE** Application Form applicants. Uncollected checks will be despatched by ordinary post (at the applicants’ own risk) to the addresses specified in the relevant Application Forms. Further information is set out in the paragraph headed “Despatch/Collection of Share Certificates/e-Refund payment instructions/Refund Checks” under the section headed “How to apply for Hong Kong Offer Shares” in this prospectus. For details of the structure of the Global Offering, including its conditions, please refer to the section headed “Structure of the Global Offering”.

---

## CONTENTS

---

*You should rely only on the information contained in this prospectus and the Application Forms to make your investment decision.*

*We have not authorized anyone to provide you with information that is different from what is contained in this prospectus.*

*Any information or representation not made in this prospectus must not be relied on by you as having been authorized by us, the Global Coordinator, the Underwriters, any of their respective directors or any other person or party involved in the Global Offering.*

	<i>Page</i>
<b>Expected Timetable</b> .....	i
<b>Summary</b> .....	1
<b>Definition</b> .....	13
<b>Glossary of Technical Terms</b> .....	22
<b>Forward-looking Statements</b> .....	25
<b>Risk Factors</b> .....	26
<b>Waivers from Compliance with the Companies Ordinance and the Listing Rules</b> .....	46
<b>Information about the Prospectus and the Global Offering</b> .....	50
<b>Directors and Parties Involved in the Global Offering</b> .....	55
<b>Corporate Information</b> .....	59
<b>Industry Overview</b> .....	61
<b>Regulation</b> .....	67
<b>History and Development</b> .....	72
<b>Business</b> .....	89
<b>Our Relationship with Certain Customers and Suppliers</b> .....	115
<b>Directors and Senior Management</b> .....	124
<b>Share Capital</b> .....	129
<b>Substantial Shareholders</b> .....	132
<b>Financial Information</b> .....	134
<b>Future Plans and Use of Proceeds</b> .....	175
<b>Underwriting</b> .....	177
<b>Structure of the Global Offering</b> .....	184
<b>How to Apply for Hong Kong Offer Shares</b> .....	191
<b>Appendix I — Accountants' Report</b> .....	I-1
<b>Appendix II — Unaudited Pro Forma Financial Information</b> .....	II-1
<b>Appendix III — Profit Forecast</b> .....	III-1
<b>Appendix IV — Property Valuation</b> .....	IV-1
<b>Appendix V — Summary of the Constitution of our Company and Cayman Islands Company Law</b> .....	V-1
<b>Appendix VI — Statutory and General Information</b> .....	VI-1
<b>Appendix VII — Documents Delivered to the Registrar of Companies and Available for Inspection</b> .....	VII-1

---

## SUMMARY

---

*This summary aims to give you an overview of the information contained in this prospectus. As this is a summary, it does not contain all the information that may be important to you. You should read the entire prospectus before you decide to invest in our Offer Shares. There are risks associated with any investment. Some of the particular risks in investing in our Offer Shares are set out in the section headed "Risk Factors". You should read this section carefully before you decide to invest in our Offer Shares.*

### OVERVIEW

We are one of the few one-stop providers of wireless communication antennas and base station radio frequency, or RF, subsystems in China. By strategically locating our principal operations in China, we aim to capitalize on its fast growing mobile communication and equipment manufacturing industry that supplies the rapidly growing worldwide demand for mobile communication infrastructure equipment. Our business consists of the design, manufacture, marketing and sale of antennas, base station RF subsystems and solutions that are the required components of mobile communication coverage systems, including wireless access systems (WiFi and PHS), 2G (GSM and CDMA), 3G (TD-SCDMA, CDMA 2000, W-CDMA and WiMax), satellite communication and microwave transmission networks. Our product portfolio is categorized into three principal groups: antenna systems, base station RF subsystems and coverage extension solutions. We sell our products to network operators in China and overseas directly for deployment into the networks they are constructing and operating. We also sell our products to wireless network solution providers who incorporate our products into their wireless coverage solutions, such as their proprietary base stations, which they then sell to network operators worldwide.

Our sophisticated technical skills and design experience in developing antennas and base station RF subsystems enable us to be qualified as an equipment supplier to some of the world's leading wireless network solution providers, such as ZTE, Nokia Siemens Networks and Alcatel-Lucent. We also focus our marketing strategy on expanding our market share in China and certain international markets, particularly the rapidly growing emerging market countries that represent some of the greatest growth opportunities in the construction of wireless communication infrastructure, as wireless networks offer a highly cost-effective way of establishing communication infrastructure in these regions.

We are committed to providing quality and sophisticated products and building long term relationships with our customers. For the years ended December 31, 2006, 2007, 2008 and the eight months ended August 31, 2009, our revenues were approximately RMB361.0 million, RMB626.8 million, RMB671.2 million and RMB632.4 million, respectively. Our net profits for the same periods were approximately RMB31.5 million, RMB56.8 million, RMB61.9 million and RMB84.2 million, respectively.

The following table sets forth the revenue in each of our product groups and as a percentage of our total revenue for the periods indicated.

	For the Year Ended December 31,						For the Eight Months Ended August 31,			
	2006		2007		2008		2008		2009	
	<i>RMB</i>	%	<i>RMB</i>	%	<i>RMB</i>	%	<i>RMB</i>	%	<i>RMB</i>	%
	<i>(unaudited)</i>									
	<i>(in thousands, except percentages)</i>									
<b>Antenna System</b>	186,392	51.7%	268,751	42.9%	260,543	38.8%	129,641	30.4%	276,282	43.7%
<b>Base Station RF Subsystem</b>	165,433	45.8%	340,940	54.4%	388,675	57.9%	285,025	66.8%	274,501	43.4%
<b>Coverage Extension Solution</b>	9,131	2.5%	17,115	2.7%	21,964	3.3%	11,772	2.8%	81,584	12.9%
<b>Total Revenues</b>	<u>360,956</u>	<u>100.0%</u>	<u>626,806</u>	<u>100.0%</u>	<u>671,182</u>	<u>100.0%</u>	<u>426,438</u>	<u>100.0%</u>	<u>632,367</u>	<u>100.0%</u>

---

## SUMMARY

---

### OUR COMPETITIVE STRENGTHS

We believe we benefit from the following competitive strengths:

- strong relationships with all the PRC domestic wireless network operators and many of the world's leading wireless network solution providers;
- strong research and development capability;
- comprehensive product portfolio for the RF path;
- close proximity to suppliers and customers, and competitive cost structure; and
- capable management and engineering team.

### OUR BUSINESS STRATEGIES

We seek to increase our revenue, market share and customer base while controlling our working capital requirements and maintain low costs through implementing the following strategies:

- maximize 3G opportunities by working closely with our key customers;
- leverage our research and development platform to develop our customer base and increase our technology sophistication;
- capitalize on our low cost structure to gain market shares; and
- further expand our customer base to other solution providers and network operators worldwide.

### INFORMATION ON OUR FINANCIAL INVESTORS

SB Asia, Cisco and Manitou are financial investors who have invested in our Company. SB Asia will be a substantial shareholder of our Company upon Listing. Yan Andrew Y. and Yang Dong were nominated by SB Asia as our Directors. We do not have any past or current business relationship with SB Asia. Each of Cisco and Manitou is an Independent Third Party without any past or current business relationship with us.

#### **SB Asia**

SB Asia is a US\$404 million fund established under the laws of Cayman Islands in 2001 and managed by SOFTBANK, Inc. SAIF Advisors Limited is an investment advisor to SAIF Management II Limited. Our Director, Yan Andrew Y., was the founder of and has been the managing partner of SAIF Advisors Limited since 2001, and our Director, Yang Dong, is currently a partner at an affiliate of SAIF Advisors Limited.

#### **Cisco**

Cisco, a private company with limited liability incorporated under the laws of the Netherlands, is a wholly-owned subsidiary of Cisco Systems, Inc. Cisco Systems, Inc. is a leader in the innovation of Internet Protocol (IP)-based networking technologies and the development of routing and switching and numerous advanced technologies including application networking services, collaboration home networking, security, storage area networking, telepresence systems, unified communications, unified computing, video systems and wireless.

---

## SUMMARY

---

### Manitou

Manitou is a venture fund established in 2001 under the laws of the State of Delaware, the United States and managed by Manitou Venture Management I, LLC. Manitou invests in early and mid-stage companies, based either in Asia or the United States, with a focus on Asian markets such as the PRC and Taiwan. The primary investment focus of Manitou is high growth technology sectors including telecommunications, internet, new media, semiconductors and information technology services.

### LEGAL PROCEEDINGS

In December 2004, MOBI Shenzhen was alleged to have infringed a utility model patent of Guangdong Tongyu Communications Equipment Co., Ltd., (formerly known as Zhong Shan Tongyu Communications Equipment Co., Ltd.) (“Tongyu”), which utility model patent is a type of waterproof feeder structure for omni-directional antennas. Subsequently, we made an application to the Patent Review Committee to invalidate that utility model patent. Thereafter, the Patent Review Committee invalidated Tongyu’s utility model patent in part, which ruling was then upheld by The Beijing First Intermediate People’s Court and The Beijing Superior People’s Court, respectively, within their jurisdiction. On September 3, 2007, The Intermediate People’s Court of Shenzhen issued a first instance verdict in the corresponding civil proceedings dismissing the allegation of patent infringement. On September 30, 2007, an appeal against such first instance verdict was filed with The Guangdong Superior People’s Court. On June 23, 2008, The Guangdong Superior People’s Court issued a final civil judgment to affirm the first instance decision and dismissed the allegation of patent infringement. MOBI Shenzhen was found not liable for any damages. On September 15, 2009, Tongyu filed an application for retrial with The Supreme People’s Court of the PRC. On November 2, 2009, the Company received a notice dated October 16, 2009 from The Supreme People’s Court of the PRC stating that the said retrial application was accepted. We have been advised by our legal advisers as to PRC laws that after acceptance of Tongyu’s application for retrial, The Supreme People’s Court of the PRC will review the application and make a decision as to whether to retry the case within three months from the date of the acceptance of the application. If The Supreme People’s Court of the PRC decides not to retry the case on the ground for retrial presented by Tongyu, the case will be closed unless Tongyu files a new retrial application based on other grounds. Any such new application for retrial must be made within 2 years from June 23, 2008, being the effective date of the final judgment issued by The Guangdong Superior People’s Court, or where the said judgment is revoked or modified after the said 2-year period and it is established that there had been misconduct by the personnel handling the original trial, within three months from the date Tongyu became aware of the same or should be aware of the same. If The Supreme People’s Court of the PRC decides to retry the case, it may retry the case by itself or order The Guangdong Superior People’s Court or other Superior People’s Court to retry it. In accordance with the retrial application, Tongyu seeks to revoke the final civil judgment granted by The Guangdong Superior People’s Court and to claim an aggregate amount of RMB20.0 million as damages for infringement. As of the Latest Practicable Date, our legal advisers as to PRC laws estimated that in the event that Tongyu succeeds in its claim against us in the retrial and if the retrial court is unable to assess the amount of profits that had been earned by the patent in dispute, we may be exposed to a maximum potential liability, if any, of approximately RMB500,000 under the PRC laws. A provision of RMB500,000 was made as at August 31, 2009.

Pursuant to a deed of indemnity dated November 27, 2009, the Beneficial Owners and Fangyi Holdings, our single largest shareholder, with equity interests in approximately 29.86% of our entire issued share capital, have jointly and severally given indemnities in favour of us (for ourselves and as trustee for our subsidiaries) for any claims, damages, losses, liabilities, expenses and proceedings incurred or suffered, or which may be incurred or suffered, by us in an aggregate amount exceeding RMB500,000 in respect of the aforesaid legal proceedings and other potential litigations.

Save as disclosed above, as at the Latest Practicable Date, there were no legal proceedings or arbitrations, pending or threatened, against us that could have a material adverse effect on our financial condition or results of operation.

---

## SUMMARY

---

### BASIS OF PRESENTATION

Our Company is an exempted company incorporated with limited liability in the Cayman Islands on December 16, 2002. Our Company is an investment holding company. The principal activities of our subsidiaries are the manufacture and sale of antennas and base station RF subsystems. Our financial information is presented in Renminbi, which is also our functional currency. The consolidated statement of comprehensive income and the consolidated statement of cash flow for the three years ended December 31, 2008 and eight months ended August 31, 2009 present the results of operations and cash flows. Our consolidated statement of financial position as of December 31, 2006, December 31, 2007, December 31, 2008 and August 31, 2009 present our assets and liabilities as of those dates.

### SUMMARY CONSOLIDATED FINANCIAL STATEMENTS

The summary selected consolidated statements of comprehensive income and consolidated statements of financial position information presented below for the periods indicated is derived from our consolidated financial statements included in Appendix I — “Accountants’ Report” and you should read the entire financial statements included therein, including the notes thereto, for more details. Our consolidated financial information has been prepared in accordance with HKFRSs.

	For the Year Ended December 31,			For the Eight Months Ended August 31,	
	2006	2007	2008	2008	2009
	<i>(unaudited)</i>				
	<i>(RMB in thousands, except per share information)</i>				
<b>Selected Consolidated Statements of Comprehensive Income</b>					
Revenue	360,956	626,806	671,182	426,438	632,367
Cost of sales	(275,888)	(472,674)	(487,884)	(312,593)	(451,873)
Gross profit	85,068	154,132	183,298	113,845	180,494
Other income	3,741	2,943	7,103	3,647	3,610
Research and development costs	(15,171)	(24,945)	(34,550)	(21,654)	(21,305)
Distribution and selling expenses	(19,223)	(27,875)	(35,170)	(17,606)	(32,055)
Administrative expenses	(20,762)	(41,819)	(47,401)	(31,766)	(31,181)
Finance costs	(153)	(2,899)	(3,803)	(2,932)	(2,664)
Profit before taxation	33,500	59,537	69,477	43,534	96,899
Income tax expense	(2,019)	(2,764)	(7,552)	(6,186)	(12,694)
Profit and the total comprehensive income for the year/period and attributable to owners of our Company	<u>31,481</u>	<u>56,773</u>	<u>61,925</u>	<u>37,348</u>	<u>84,205</u>
Earnings per share					
— basic <sup>(1)</sup>	<u>7.91 cents</u>	<u>15.21 cents</u>	<u>15.41 cents</u>	<u>8.83 cents</u>	<u>21.38 cents</u>
— diluted <sup>(2)</sup>	<u>5.99 cents</u>	<u>10.62 cents</u>	<u>11.60 cents</u>	<u>6.93 cents</u>	<u>15.50 cents</u>

## SUMMARY

*Notes:*

- (1) Basic earnings per Share of 7.91 RMB cents, 15.21 RMB cents, 15.41 RMB cents, 8.83 RMB cents and 21.38 RMB cents for the year ended December 31, 2006, 2007, 2008 and the eight months ended August 31, 2008 and 2009, respectively, are calculated by reference to the earnings of RMB29.5 million, RMB56.8 million, RMB57.6 million, RMB33.0 million and RMB79.8 million in each of the respective periods and weighted average number of Shares of 372,500,000, 373,232,000, 373,543,000, 373,543,000 and 373,543,000 in each of the respective periods.
- (2) Diluted earnings per Share of 5.99 RMB cents, 10.62 RMB cents, 11.60 RMB cents, 6.93 RMB cents and 15.50 RMB cents for the year ended December 31, 2006, 2007, 2008 and the eight months ended August 31, 2008 and 2009, respectively, are calculated by reference to the earnings of RMB31.5 million, RMB56.8 million, RMB61.9 million, RMB37.3 million and RMB84.2 million in each of the respective periods and weighted average number of Shares of 525,445,000, 534,405,000, 533,954,000, 538,789,000 and 543,140,000 in each of the respective periods.

	As of December 31,			As of
	2006	2007	2008	August 31,
	<i>(RMB in thousands)</i>			2009
<b>Selected Consolidated Statements of Financial Position</b>				
<b>Non-current assets</b>				
Property, plant and equipment	70,253	89,029	107,484	117,711
Prepaid lease payments	4,324	4,233	21,570	21,303
Deferred tax assets	—	1,527	6,000	7,384
	<u>74,577</u>	<u>94,789</u>	<u>135,054</u>	<u>146,398</u>
<b>Current assets</b>				
Inventories	51,808	127,442	222,049	290,767
Trade and other receivables	205,882	280,747	362,159	513,902
Prepaid lease payments	98	98	471	453
Pledged bank balances	1,308	8,006	14,739	41,592
Bank balances and cash	43,080	131,470	59,067	69,203
	<u>302,176</u>	<u>547,763</u>	<u>658,485</u>	<u>915,917</u>
<b>Current liabilities</b>				
Trade and other payables	153,327	281,500	380,311	490,370
Dividend payable	—	—	429	758
Tax payable	495	2,404	8,033	11,325
Entrusted bank loan	—	5,000	—	—
Short-term bank borrowings	7,909	69,500	73,454	157,744
Deferred income	54	563	563	746
Provision	500	500	500	500
	<u>162,285</u>	<u>359,467</u>	<u>463,290</u>	<u>661,443</u>
Net current assets	<u>139,891</u>	<u>188,296</u>	<u>195,195</u>	<u>254,474</u>
Total assets less current liabilities	<u>214,468</u>	<u>283,085</u>	<u>330,249</u>	<u>400,872</u>
<b>Non-current liabilities</b>				
Deferred income	1,297	3,236	2,673	3,600
Net assets	<u>213,171</u>	<u>279,849</u>	<u>327,576</u>	<u>397,272</u>
<b>Capital and reserves</b>				
Share capital	1	1	1	1
Reserves	213,170	279,848	327,575	397,271
Equity attributable to owners of our Company	<u>213,171</u>	<u>279,849</u>	<u>327,576</u>	<u>397,272</u>

---

## SUMMARY

---

### THE GLOBAL OFFERING

The Global Offering consists of:

- the offer of initially 17,552,000 Hong Kong Offer Shares for subscription by the public in the Hong Kong Public Offering; and
- the offering of initially 157,963,000 International Placing Shares outside the United States in reliance on Regulation S under the U.S. Securities Act, including to professional investors in Hong Kong, referred to in this prospectus as the International Placing.

The number of Hong Kong Offer Shares and International Placing Shares, or collectively, Offer Shares, is subject to adjustment and the Over-allotment Option as described in the section headed “Structure of the Global Offering.”

### THE EFFECT OF OUR PRE-IPO STOCK INCENTIVE PLANS

We have adopted Pre-IPO Stock Incentive Plans in 2003 and 2004 to give our officers, Directors, consultants and employees an opportunity to share our success and to motivate them, to optimize their performance and efficiency and also to retain these personnel whose contributions are important to our long term growth and profitability.

Assuming that all the outstanding options granted under the Pre-IPO Stock Incentive Plans were exercised in full on the Listing Date, the then original shareholding interest of the public would be reduced from approximately 31.6% to approximately 30.5% of the total issued share capital of our Company immediately after completion of the Global Offering, taking no account of any Shares that may be issued pursuant to the exercise of the Over-allotment Option, any Shares that may be allotted and issued pursuant to the exercise of any options granted under the Share Option Scheme or any Shares that may be issued by our Company pursuant to the general mandate as described under the paragraph headed “Extraordinary general meeting of our Company” in Appendix VI — Statutory and General Information.

Our shareholding immediately following the Global Offering, assuming the Over-allotment Option is not exercised, would be diluted by approximately 3.5% upon the exercise of the Pre-IPO Options. Assuming that (i) the Global Offering had occurred on January 1, 2009; (ii) a total of 702,057,995 Shares had been in issue during the year; (iii) all the Pre-IPO Options were exercised in full on January 1, 2009; and (iv) taking no account of any Shares that may be issued pursuant to the exercise of the Over-allotment Option, any Shares that may be allotted and issued pursuant to the exercise of any options granted under the Share Option Scheme or any Shares that may be issued by our Company pursuant to the general mandate as described under the paragraph headed “Extraordinary general meeting of our Company” in Appendix VI — Statutory and General Information, the exercise of the Pre-IPO Options will have diluted the unaudited pro forma forecast basic earnings per Share for the year ending December 31, 2009 from RMB0.1449 to RMB0.1398. Except as disclosed above, no further options will be granted under the Pre-IPO Stock Incentive Plans after the date of this prospectus.

---

## SUMMARY

---

### FUTURE PLANS

We are currently constructing our major manufacturing facility located in Jizhou Industrial Zone, Jian City, Jiangxi Province and our manufacturing and research and development facility in Xian, Shaanxi Province. The estimated capital expenditure for each of the Jian and Xian facilities (including purchases of machinery and equipment) for the three years ending December 31, 2012 are RMB61.0 million and RMB32.0 million, respectively. Please see “Business — Our Strategy” for a more detailed description of our future plans.

### USE OF PROCEEDS

We estimate that the aggregate net proceeds to us from the Global Offering (after deducting underwriting fees and estimated expenses payable by us in connection with the Global Offering and assuming an Offer Price of HK\$3.11 per Share, being the mid-point of the indicative range of the Offer Price of HK\$2.72 to HK\$3.50 per Share, and assuming the Over-allotment Option is not exercised) will be approximately HK\$510.3 million.

The principal purposes of our Global Offering are to:

- Create a public market for our ordinary shares for the benefit of all of our shareholders;
- Attract and retain high caliber employees by share options granted and to be granted; and
- Raise funds for the purposes described as follows.

We expect to spend much of the net proceeds from the Global Offering to achieve our primary objectives as follows:

#### 1. Expansion of manufacturing capacity:

In order to satisfy the increasing demand from our customers in China and overseas, we intend to use approximately HK\$153.1 million, representing approximately 30% of our net proceeds from the Global Offering, to finance further expansion of our manufacturing capacity, including without limitation, the construction of facilities in Jian and Xian, for which we expect to spend approximately RMB68.0 million, RMB6.5 million and RMB18.5 million in the year ending December 31, 2010, 2011 and 2012, respectively.

#### 2. Merger and acquisition reserve:

Although we have not identified any specific target, we intend to reserve approximately HK\$229.6 million, representing approximately 45% of our net proceeds from the Global Offering, for future acquisition of companies, businesses, assets or teams for the purpose of enhancing our position in China and overseas markets, including, without limitation:

- Expanding our product portfolio in wireless communication devices in order to maximize 3G opportunities in China and the growing demand from our international customers;
- Expanding our presence in the overseas network operator market; and
- Expanding our manufacturing capacity and sales network.

In the absence of suitable acquisition target, we intend to invest such reserved proceeds to pursue internal growth including, but not limited to, building facilities for research and development, manufacturing and storage, purchasing land, plant and equipment, establishing overseas sales offices and recruiting more staff.

---

## SUMMARY

---

### 3. Research and development on strategic products and technologies:

We intend to use approximately HK\$76.6 million, representing approximately 15% of our net proceeds from the Global Offering, to finance our research and development efforts in products and technologies development and manufacturing process improvement. We will continue to enhance our technology and develop more new products for TD-SCDMA, CDMA2000, W-CDMA, GSM, CDMA and LTE (Long Term Evolution) in the next generation of standards and protocols.

### 4. General corporate purposes:

We intend to use approximately HK\$51.0 million, representing approximately 10% of our net proceeds from the Global Offering, for general corporate purposes, including increasing our working capital as we expand.

In the event that the Offer Price is set at the high-end of the proposed Offer Price range, we will receive net proceeds of approximately HK\$576.9 million. The additional net proceeds of about HK\$66.6 million (when compared to the net proceeds with the Offer Price being determined at the mid-point of the stated range) will be allocated pro rata as if the Offer Price is set at the mid-point of the stated range of the Offer Price.

In the event that the Offer Price is set at the low-end of the proposed Offer Price range, we will receive net proceeds of approximately HK\$443.8 million. Under such circumstances, the net proceeds will be allocated pro rata as if the Offer Price is set at the mid-point of the stated range of the Offer Price.

### PROFIT FORECAST FOR THE YEAR ENDING DECEMBER 31, 2009

All statistics in this table are based on the assumption that the Over-allotment Option is not exercised.

Forecast consolidated profit attributable to owners of the Company <sup>(1)</sup> .....	Not less than RMB101.7 million (equivalent to approximately HK\$115.9 million)
Unaudited pro forma forecast basic earnings per Share <sup>(2)</sup> .....	Not less than RMB0.14 (equivalent to approximately HK\$0.16)

---

*Notes:*

1. The bases and principal assumptions on which the forecast consolidated profit attributable to owners of the Company for the year ending December 31, 2009 are extracted from the section headed "Profit Forecast" in Appendix III of the prospectus. The bases on which the above profit forecast for the year ending December 31, 2009 have been prepared are summarized in the section headed "Profit Forecast" in Appendix III to the prospectus and assuming the translation of Hong Kong dollars to Renminbi with the exchange rate at RMB1.00 to HK\$1.14.
2. The calculation of the unaudited pro forma forecast basic earnings per Share is based on the forecast consolidated profit attributable to owners of the Company for the year ending December 31, 2009 assuming that the Global Offering had occurred on January 1, 2009 and a total of 702,057,995 Shares had been in issue during the year, but does not take into account any Shares which may be issued upon the exercise of the Over-allotment Option and assuming the translation of Hong Kong dollars to Renminbi with the exchange rate at RMB1.00 to HK\$1.14.

---

## SUMMARY

---

### GLOBAL OFFERING STATISTICS

All statistics in this table are based on the assumption that the Over-allotment Option is not exercised.

	<b>Based on an Offer Price of HK\$2.72</b>	<b>Based on an Offer Price of HK\$3.50</b>
Market capitalization <sup>(1)</sup> . . . . .	HK\$1,909.6 million	HK\$2,457.2 million
Prospective price/earnings multiple on a pro forma basis <sup>(2)</sup> . . . . .	17.0 times	21.9 times
Unaudited pro forma adjusted consolidated net tangible assets per Share <sup>(3)</sup> . . . . .	RMB1.12 (equivalent to approximately HK\$1.28)	RMB1.29 (equivalent to approximately HK\$1.47)

---

*Notes:*

- (1) The calculation of market capitalization is based on 702,057,995 Shares expected to be in issue following the Global Offering.
- (2) The calculation of the prospective price/earnings multiple on a pro forma basis is based on the unaudited pro forma forecast earnings per Share at the respective issue prices of HK\$2.72 and HK\$3.50.
- (3) The unaudited pro forma net tangible asset value per Share has been arrived at after adjustment referred to in the paragraph headed “Unaudited pro forma adjusted net tangible assets” in the Unaudited Pro Forma Financial Information in Appendix II to this prospectus, and is based on 702,057,995 Shares expected to be in issue following the Global Offering.

### SUMMARY OF RISK FACTORS

#### Risks Related to our Company

- Our business and results of operations are affected by economic cycles, including the recent global financial and economic crisis.
- We rely upon a few customers for the majority of our revenues and the loss of any one of these customers, or a significant loss, reduction or rescheduling of orders from any of these customers, could have a material adverse effect on our business, results of operations and financial condition.
- We generally do not enter into long-term contracts with our customers.
- Failure by the wireless telecommunication sector in China to maintain its current pace of growth could materially and adversely affect our profitability and future prospects.
- If we cannot continue to rapidly develop, manufacture and market innovative products and services that meet customer requirements for performance and reliability, we may lose market share and our revenue may suffer.
- If we lose our ability to design customized products and solutions to meet our customers’ requirements, our reputation and relationships with our customers may be damaged and we may incur significant warranty costs or other liabilities, any of which may materially and adversely affect our revenue growth.
- Sales of our RF products and solutions may decrease as a result of our failure to develop commercially successful or viable RF products and solutions.

---

## SUMMARY

---

- We are subject to risks related to product defects that could result in product recalls and could subject us to warranty claims that are greater than anticipated. If we were to experience a product recall or an increase in warranty claims that exceed our forecast, our sales and operating results could be adversely affected.
- If we fail to effectively implement our production plan, our results of operations may be materially and adversely affected.
- Our failure to acquire raw materials or to fill our customers' orders in a timely and cost-effective manner could materially and adversely affect our business operations.
- Our suppliers, contract manufacturers or customers could become competitors.
- A substantial portion of our sales is made outside the PRC. Conducting business in international markets involves risks and uncertainties such as foreign exchange rate exposure and political and economic instability that could lead to reduced international sales and reduced profitability associated with such sales.
- We have experienced, and will continue to experience, significant fluctuations in sales and operating results from period to period.
- The initial vendor qualification cycle associated with the sales of our products is typically lengthy, often lasting from six months to a year, which could cause delays in forecasted sales and cause us to incur substantial expenses before we record any associated revenues.
- Our key managerial and technical personnel are critical to the success of our business and if we fail to attract or retain such personnel we may compromise our ability to maintain strong relationships with customers and suppliers, develop new products and effectively carry on our research and development and other efforts.
- The selling prices of our earlier products have decreased over time, and we anticipate that the selling prices for our existing products may decrease over time. If we cannot supplement our product portfolio with new products that have higher selling prices or lower the production costs of our products, our gross margin will decline.
- We may experience delays or defaults in collecting trade receivables from our customers, which may adversely affect our cash flow and working capital, financial condition and operating results.
- The non-transferrability of the property right in one of the properties we own may undermine our ownership interest.
- Our operations may be disrupted due to our landlords' lack of the relevant title certificates as to certain leased properties.
- Our lack of comprehensive intellectual property rights may undermine our competitive position, and litigation to protect our intellectual property rights or to defend against third-party allegations of infringement may be costly.
- We may be exposed to infringement or misappropriation claims by third parties, which, if determined adversely to us, could cause us to pay significant damage awards.
- We generally do not carry product liability insurance for our RF products and solutions, and any significant product liability claim could have a material and adverse effect on our financial condition.

---

## SUMMARY

---

### **Risks Related to our Industry**

- Failure of commercialization of 3G services, particularly TD-SCDMA technology in China or globally, could materially and adversely affect our profitability and future prospects.
- The telecommunications industry has experienced significant consolidation and this trend is expected to continue. Any disruption in our direct business relationship with any of our major customers as a result of market consolidation will adversely affect our sales and profitability.
- The competitive bidding process in the telecommunication infrastructure industry can result in our revenues fluctuating significantly from period to period.
- Our success is tied to the growth of the market for wireless communications services and our future revenue growth is dependent upon the expected increase in the size of this market.
- The wireless communication industry in China is extremely competitive and our inability to compete effectively would be detrimental to our current business and prospects for future growth.
- Our business may be subject to various regulatory restrictions, and any new regulation may restrict our methods of conducting business and subject us to severe penalties.
- Actual or perceived health risks from the electromagnetic fields generated by base stations and mobile devices could negatively affect our operations by leading regulatory authorities to impose more stringent telecommunication equipment standards or causing consumers to reduce their use of mobile devices.

### **Risks Related to our Operations in the PRC**

- Changes in the PRC's political, economic and social conditions, laws, regulations and policies may have an adverse effect on us.
- The PRC's legal system embodies uncertainties that could adversely affect our business and results of operations.
- A newly enacted PRC tax law could affect tax exemptions on dividends received by us and our shareholders and increase our enterprise income tax rate.
- Gain on the sales of our Shares and dividends on our Shares may be subject to PRC income taxes.
- Fluctuations in the exchange rates of the RMB may adversely affect your investment and could materially affect our financial condition and results of operations.
- It may be difficult to effect service of process upon us or our Directors who live in the PRC or to enforce against us or them in the PRC judgments obtained from non-PRC courts.
- An outbreak of Severe Acute Respiratory Syndrome (SARS), Avian Flu (H5N1), Influenza A (H1N1) or any other similar epidemic may, directly or indirectly, adversely affect our operating results and the price of our Shares.
- Our corporate structure may restrict our ability to receive dividends from, and transfer funds to, our PRC operating subsidiary, which could restrict our ability to act in response to changing market conditions in a timely manner.

---

## SUMMARY

---

### **Risk Related to the Global Offering**

- Purchasers of our Offer Shares will experience substantial and immediate dilution and may experience further dilution if we issue additional Shares in the future.
- Dividends declared in the past may not be indicative of our dividend policy in the future.
- Future sales by our Directors, officers and our current shareholders of a substantial number of our Shares in the public market could materially and adversely affect the prevailing market price of our Shares.
- The interests of our substantial shareholders may differ from your interests and their votes may disadvantage our minority shareholders.
- We cannot guarantee the accuracy of certain facts and statistics with respect to the PRC, the PRC economy and the wireless communication industry contained in this prospectus.
- Investors should read this entire prospectus carefully and we strongly caution you not to place any reliance on any information contained in press articles or other media regarding us and the Global Offering including, in particular, any financial projections, valuations or other forward looking statement.

---

## DEFINITION

---

In this prospectus, unless the context otherwise requires, the following expressions shall have the following meanings. Certain other terms are explained in the section headed “Glossary of Technical Terms”.

“Andrew”	Andrew Corporation, an Independent Third Party, and its affiliated entities where the context so requires
“Alcatel”	Alcatel SA, an Independent Third Party, and its affiliated entities where the context so requires
“Alcatel-Lucent”	Alcatel Lucent and its affiliated entities where the context so requires, an Independent Third Party
“Application Form(s)”	<b>WHITE</b> Application Form(s), <b>YELLOW</b> Application Form(s) and <b>GREEN</b> Application Form(s), or where the context so requires, any of them, relating to the Hong Kong Public Offering
“Articles”	the articles of association of our Company (as amended from time to time)
“Beneficial Owners”	the 39 shareholders of Fangyi Holdings whose names and respective shareholdings in Fangyi Holdings are set forth in the section headed “History and Development” of this prospectus
“Capitalization Issue”	the issue of Shares to be made upon the capitalization of part of the share premium account of our Company
“CCASS”	the Central Clearing and Settlement System established and operated by HKSCC
“CCASS Clearing Participant”	a person admitted to participate in CCASS as a direct clearing participant or general clearing participant
“CCASS Custodian Participant”	a person admitted to participate in CCASS as a custodian participant
“CCASS Investor Participant”	a person admitted to participate in CCASS as an investor participant who may be an individual or joint individuals or a corporation
“CCASS Participant”	a CCASS Clearing Participant, a CCASS Custodian Participant or a CCASS Investor Participant
“CCID”	CCID Consulting Company Limited, an industry research firm affiliated with the PRC Ministry of Information Industry
“China” or “PRC”	the People’s Republic of China excluding, for the purpose of this prospectus, Hong Kong, the Macau Special Administrative Region of the PRC and Taiwan
“China Mobile”	China Mobile Communication Corporation, an Independent Third Party, and its affiliated entities where the context so requires

---

## DEFINITION

---

“China Netcom”	China Network Communications Group Corporation, an Independent Third Party, and its affiliated entities where the context so requires
“China Telecom”	China Telecommunications Corporation, an Independent Third Party, and its affiliated entities where the context so requires
“China Unicom”	China United Telecommunications Corporation, an Independent Third Party, and its affiliated entities where the context so requires
“Cisco”	Cisco Systems International B.V., a shareholder of the Company
“Comba”	Comba Telecom Systems Holdings Limited (京信通信系統控股有限公司), an Independent Third Party, and its affiliated entities where the context so requires
“CommScope”	CommScope, Inc., an Independent Third Party, and its affiliated entities where the context so requires
“Company”, “MOBI”, “our”, “we” and “us”	MOBI Development Co., Ltd. (摩比發展有限公司), an exempted company incorporated in the Cayman Islands on December 16, 2002 under the Companies Law with limited liability
“Companies Law”	the Companies Law, Cap 22 (Law 3 of 1961, as amended, supplemented or otherwise modified from time to time) of the Cayman Islands
“Companies Ordinance”	the Companies Ordinance, Chapter 32 of the Laws of Hong Kong, as amended and supplemented from time to time
“CSRC”	the China Securities Regulatory Commission
“Datang Telecom”	Datang Telecom Technology Co., Ltd. (大唐電信科技股份有限公司), an Independent Third Party, and its affiliated entities where the context so requires
“Director(s)” or “Board of Directors”	director(s) or the board of directors of our Company, respectively
“Fangyi Holdings”	Fangyi Collaboration Holdings Limited, a limited liability company incorporated under the laws of the British Virgin Islands and a substantial shareholder of the Company
“Fingu”	Wuhan Fingu Electronic Technology Co., Ltd. (武漢凡谷電子技術股份有限公司), an Independent Third Party, and its affiliated entities where the context so requires
“First Shanghai Capital”	First Shanghai Capital Limited, which is licensed under the SFO for type 6 (advising on corporate finance) regulated activity as defined under the SFO

---

## DEFINITION

---

“First Shanghai Securities”	First Shanghai Securities Limited, which is licensed under the SFO for type 1 (dealing in securities), type 4 (advising in securities), type 6 (advising on corporate finance) and type 9 (asset management) regulated activities as defined under the SFO
“Global Offering”	the Hong Kong Public Offering and the International Placing
“Green Application Form(s)”	the application form(s) to be completed by White form eIPO Service Provider designated by our Company
“Grentech”	China Grentech Co., Ltd. (深圳國人通信股份有限公司), an Independent Third Party, and its affiliated entities where the context so requires
“Group”	our Company and its subsidiaries (or our Company and any one or more of its subsidiaries, as the context may require)
“Guangdong Shenglu”	Guangdong Shenglu Telecommunication Tech Co., Ltd. (廣東盛路通信科技股份有限公司), an Independent Third Party, and its affiliated entities where the context so requires
“HK\$” or “HK dollars” and “cents”	Hong Kong dollars and cents respectively, the lawful currency of Hong Kong
“HKFRSs”	Hong Kong Financial Reporting Standards
“HKSCC”	Hong Kong Securities Clearing Company Limited
“HKSCC Nominees”	HKSCC Nominees Limited
“Hong Kong”	the Hong Kong Special Administrative Region of the PRC
“Hong Kong Offer Shares”	the 17,552,000 New Shares being initially offered by our Company at the Offer Price pursuant to the Hong Kong Public Offering (subject to reallocation as described in the section headed “Structure of the Global Offering” in this prospectus)
“Hong Kong Public Offering”	our offer to the public in Hong Kong for subscription of the Hong Kong Offer Shares for cash (subject to adjustment as described in the section headed “Structure of the Global Offering” in this prospectus) at the Offer Price (plus brokerage fee of 1.0%, Stock Exchange trading fee of 0.005%, and SFC transaction levy of 0.004%) on the terms and subject to the conditions described in this prospectus and the Application Forms, as further described in the paragraph headed “The Hong Kong Public Offering” under the section headed “Structure of the Global Offering” in this prospectus
“Hong Kong Underwriters”	the underwriters listed in the paragraph headed “Underwriters — Hong Kong Underwriters” under the section headed “Underwriting” in this prospectus, being the underwriters of the Hong Kong Public Offering

---

## DEFINITION

---

“Hong Kong Underwriting Agreement”	the underwriting agreement dated December 3, 2009 relating to the Hong Kong Public Offering and entered into by, among others, the Global Coordinator, the Hong Kong Underwriters and our Company, as further described in the paragraph headed “Underwriting arrangements and expenses” under the section headed “Underwriting” in this prospectus
“Huawei”	Huawei Technologies Co., Ltd. (華為技術有限公司), an Independent Third Party, and its affiliated entities where the context so requires
“Independent Third Party(ies)”	party which is not a connected person (as defined in the Listing Rules) and “Independent Third Parties” shall be construed accordingly
“International Placing”	the conditional placing of the International Placing Shares by the International Underwriters with professional and institutional investors at the Offer Price, as further described in the section headed “Structure of the Global Offering” in this prospectus
“International Placing Shares”	the 157,963,000 New Shares initially being offered by our Company for subscription at the Offer Price under the International Placing together, where relevant, with any additional Shares that may be issued pursuant to any exercise of the Over-allotment Option
“International Underwriting Agreement”	the International Underwriting Agreement relating to the International Placing to be entered into on or about December 10, 2009 by, among others, the Global Coordinator, the International Underwriters and our Company, as further described in the paragraph headed “International Placing” under the section headed “Underwriting” in this prospectus
“International Underwriters”	the underwriters listed in the paragraph headed “Underwriters — International Underwriters” under the section headed “Underwriting” in this prospectus, being the underwriters of the International Placing
“ITI”	ITI Limited, an Independent Third Party, and its affiliated entities where the context so requires
“Joint Bookrunners”	Piper Jaffray Asia Securities and First Shanghai Securities
“Joint Sponsors”	Piper Jaffray Asia and First Shanghai Capital
“Junyi Holdings”	Junyi Holdings Ltd., a limited liability company incorporated under the laws of the British Virgin Islands, a shareholder of the Company
“Kang Cheng”	Shenzhen Kang Cheng Jixie Shebei Co., Ltd. (深圳市康誠機械設備有限公司)

---

## DEFINITION

---

“Kathrein-Werke”	Kathrein-Werke KG, an Independent Third Party, and its affiliated entities where the context so requires
“Latest Practicable Date”	November 27, 2009, being the latest practicable date for the purpose of ascertaining certain information contained in this prospectus prior to its publication
“Listing”	listing of the Shares on the Main Board of the Stock Exchange
“Listing Date”	the date, expected to be on or about December 17, 2009, on which our Shares are listed and from which dealings therein are permitted to take place on the Stock Exchange
“Listing Rules”	the Rules Governing the Listing of Securities on the Stock Exchange (as amended from time to time)
“Lucent”	Lucent Technologies, an Independent Third Party, and its affiliated entities where the context so requires
“Main Board”	the stock exchange (excluding the option market) operated by the Stock Exchange which is independent from and operated in parallel with the Growth Enterprise Market of the Stock Exchange
“Manitou”	Manitou Ventures I, L.P., a shareholder of the Company
“Memorandum of Association” or “Memorandum”	the memorandum of association of the Company (as amended from time to time)
“MII”	Ministry of Information Industry of the PRC
“MOBI Jian”	MOBI Telecommunication Technologies (Jian) Co., Ltd. (摩比通訊技術(吉安)有限公司), a company established in the PRC and a wholly-owned subsidiary of our Company
“MOBI Shenzhen”	MOBI Antenna Technologies (Shenzhen) Co., Ltd. (摩比天線技術(深圳)有限公司), a company established in the PRC and a wholly-owned subsidiary of our Company
“MOBI Xian”	MOBI Technologies (XI’ AN) Co., Ltd. (摩比科技(西安)有限公司), a company established in the PRC and a wholly-owned subsidiary of MOBI Shenzhen
“Motorola”	Motorola, Inc. and its affiliated entities where the context so requires, an Independent Third Party
“NEC”	NEC Corporation and its affiliated entities where the context so requires, an Independent Third Party
“New Shares”	a total of 175,515,000 Shares initially being offered by our Company under the Global Offering
“Nortel Networks”	Nortel Networks Corporation, an Independent Third Party, and its affiliated entities where the context so requires

---

## DEFINITION

---

“Offer Price”	the final offer price per Offer Share (exclusive of brokerage fee of 1.0%, SFC transaction levy of 0.004% and Stock Exchange trading fee of 0.005%) of not more than HK\$3.50, such price to be agreed upon by our Company and the Global Coordinator (on behalf of the Underwriters) on or around Price Determination Date
“Offer Shares”	the Hong Kong Offer Shares and the International Placing Shares
“Over-allotment Option”	the option to be granted by our Company to the Global Coordinator (on behalf of the International Underwriters), pursuant to the International Underwriting Agreement, to require our Company to issue up to an aggregate of 26,327,000 additional New Shares at the Offer Price to cover, among other things, over-allocations in the International Placing, if any, exercisable at any time from the date of International Underwriting Agreement up to (and including) the date which is the 30th day from the last day for the lodging of applications under the Hong Kong Public Offering
“Piper Jaffray Asia”	Piper Jaffray Asia Limited, which is licensed under the SFO for type 1 (dealing in securities) and type 6 (advising on corporate finance) regulated activities as defined under the SFO
“Piper Jaffray Asia Securities” or “Global Coordinator” or “Lead Manager”	Piper Jaffray Asia Securities Limited, which is licensed under the SFO for type 1 (dealing in securities) and type 4 (advising on securities) regulated activities as defined under the SFO
“Powerwave”	Powerwave Technologies, Inc. and its affiliated entities where the context so requires
“Pre-IPO Options”	options granted to eligible persons under the Pre-IPO Stock Incentive Plans
“Pre-IPO Stock Incentive Plans”	the 2003 Stock Incentive Plan and the 2005 Stock Incentive Plan
“Preferred Shares”	voting preferred shares in our Company with a nominal value of US\$0.000001 each
“Price Determination Agreement”	the agreement to be entered into between us and the Global Coordinator (on behalf of the Hong Kong Underwriters) pursuant to the Hong Kong Underwriting Agreement on the Price Determination Date to record and fix the Offer Price
“Price Determination Date”	on or around December 10, 2009 (Hong Kong time) at which time the Offer Price is determined, or such later time as our Company and the Global Coordinator (on behalf of the Hong Kong Underwriters) may agree, but in any event not later than December 12, 2009
“Property Valuation Report”	the summary of valuation and valuation certificates from Savills Valuation and Professional Services Limited, as set out in Appendix IV to this prospectus

---

## DEFINITION

---

“RAB”	Radio Administration Bureau (State Radio Office) of the MII
“Regulation S”	Regulation S under the U.S. Securities Act
“Reliance”	Reliance Communications Limited, an Independent Third Party, and its affiliated entities where the context so requires
“Reorganization”	the reorganization of our Group in preparation for the listing of the Shares on the Stock Exchange, details of which are set out in the sub-paragraph headed “Corporate reorganization” under the paragraph headed “Further information about our Company” in Appendix VI to this prospectus
“RFS”	Radio Frequency Systems and its affiliated entities where the context so requires
“RMB”	Chinese Yuan Renminbi, the lawful currency of the PRC, excluding, for purposes of this prospectus, Hong Kong, the Macau Special Administrative Region of the PRC and Taiwan
“SAFE”	The State Administration of Foreign Exchange
“SAIC”	The State Administration for Industry and Commerce
“SB Asia”	SB Asia Infrastructure Fund L.P., a substantial shareholder of the Company
“Series A Preferred Share Warrant”	warrant granted by our Company to SB Asia, details of which are set out in the paragraph headed “Post-reorganization Developments” in the section headed “History and Development” of this prospectus
“Series A Preferred Shares”	the 50,000,000 Preferred Shares that have been designated as “Series A Preferred Shares”
“SFC”	The Securities and Futures Commission of Hong Kong
“SFO”	The Securities and Futures Ordinance, Chapter 571 of the Laws of Hong Kong, as amended and supplemented from time to time
“Share Option Scheme”	the Share Option Scheme conditionally adopted by us on November 25, 2009, details of which are set out in the paragraph headed “Share Option Scheme” in Appendix VI to this prospectus
“Share Warrant”	warrant granted by our Company to Shenzhen Weixiantong acting for and on behalf of the Beneficial Owners, details of which are set out in the paragraph headed “Post-reorganization Developments” in the section headed “History and Development” of this prospectus

---

## DEFINITION

---

“Shareholders’ Agreement”	a shareholders’ agreement dated December 19, 2002 entered into among our Company, MOBI Shenzhen, SB Asia, Shenzhen Weixiantong, Qu Deqian, Wang Beirong, Hu Xiang, Wang Guoying, Shao Zhiguo, Hou Weigui and the 39 Employee Shareholders
“Shares”	voting ordinary shares in our Company with a nominal value of US\$0.000001 each
“Shenglongfeng”	Shenzhen Shenglongfeng Industrial Co., Ltd. (深圳市盛隆豐實業有限公司)
“Shenzhen Land Bureau”	Shenzhen Municipal Bureau of Land Resources and Housing Management
“Shenzhen Weixiantong”	Shenzhen Zhongxin Weixiantong Shebei Co., Ltd. (深圳市中興維先通設備有限公司), which is owned by the Beneficial Owners in the same proportion to their shareholding in Fangyi Holdings
“Shenzhen Zhongxingxin”	Shenzhen Zhongxingxin Tongxun Shebei Co., Ltd. (深圳市中興新通訊設備有限公司)
“SIPO”	the State Intellectual Property Office of the PRC
“Stabilization Manager”	Piper Jaffray Asia Securities
“State Council”	The State Council of the People’s Republic of China (中華人民共和國國務院)
“Stock Borrowing Agreement”	the stock borrowing agreement expected to be entered into on or about the Price Determination Date between the Stabilization Manager (or its affiliate acting on its behalf) and Fangyi Holdings, pursuant to which Fangyi Holdings will agree to lend up to 26,327,000 Shares to the Stabilization Manager on the terms set forth therein
“Stock Exchange”	The Stock Exchange of Hong Kong Limited, a wholly-owned subsidiary of Hong Kong Exchanges and Clearing Limited
“Takeovers Code”	the Code on Takeovers and Mergers of Hong Kong
“Underwriters”	the Hong Kong Underwriters and the International Underwriters
“Underwriting Agreements”	the Hong Kong Underwriting Agreement and the International Underwriting Agreement
“U.S.” or “United States”	the United States of America, its territories, its possessions and all areas subject to its jurisdiction
“US\$” or “U.S. dollars”	United States dollars, the lawful currency of the United States
“U.S. Securities Act”	the United States Securities Act of 1933 (as amended from time to time)
“UTStarcom”	UTStarcom, Inc., an Independent Third Party, and its affiliated entities when the context so requires

---

## DEFINITION

---

“Warrants”	the Share Warrant and the Series A Preferred Share Warrant
“White Form eIPO”	the application for Hong Kong Offer Shares to be issued in the applicant’s own name by submitting applications online through the designated website of White Form eIPO <a href="http://www.eipo.com.hk">www.eipo.com.hk</a>
“White Form eIPO Service Provider”	Computershare Hong Kong Investor Services Limited
“Xi’an Haitian”	Xi’an Haitian Antenna Technologies Co., Ltd. (西安海天天綫科技股份有限公司), an Independent Third Party, and its affiliated entities where the context so requires
“Zhongxingxindi”	Shenzhen Zhongxingxindi Tongxin Qicai Co., Ltd. (深圳市中興新地通信器材有限公司)
“ZTE”	ZTE Corporation (中興通訊股份有限公司), a company listed on the Main Board of the Stock Exchange (stock code: 0763) and on the Shenzhen Stock Exchange (stock code: 000063) and its affiliated entities where the context so requires
“2003 Stock Incentive Plan”	the pre-IPO stock incentive plan approved and adopted by our Company on January 15, 2003, the principal terms of which are summarized in the section headed “5. Pre-IPO Options” in Appendix VI to this prospectus
“2005 Stock Incentive Plan”	the pre-IPO stock incentive plan approved and adopted by our Company on July 10, 2005, the principal terms of which are summarized in the section headed “5. Pre-IPO Options” in Appendix VI to this prospectus
“39 Employee Shareholders”	the 39 individuals who were allotted and issued a total of 3,255,650 Shares on December 19, 2002 and who were either employees or consultants of our Group at the time of such allotment and issuance (with only 25 employees and three consultants remaining with our Group as of the Latest Practicable Date. Two out of the three consultants are also employees of our Group involved in provision of legal and technology advisory services to our Group respectively)

In this prospectus, the terms “associate”, “connected person”, “connected transaction”, “controlling shareholder”, “subsidiary” and “substantial shareholder” shall have the meanings given to such terms in the Listing Rules, unless the context otherwise requires.

In this prospectus, unless otherwise stated, certain amounts denominated in Renminbi have been translated into HK dollars at an exchange rate of RMB1.00 = HK\$1.14 for illustration purpose only. Such conversions shall not be construed as representations that amounts in Renminbi were or may have been converted into HK dollars, U.S. dollars or Euros at such rates or any other exchange rates.

Certain amounts and percentage figures included in this prospectus have been subject to rounding adjustments. Accordingly, figures shown as totals in certain tables may not be an arithmetic aggregation of the figures preceding them.

In this prospectus, if there is any inconsistency between the Chinese names of the entities or enterprises established in the PRC and their English translations, the Chinese names shall prevail.

---

## GLOSSARY OF TECHNICAL TERMS

---

*This glossary contains explanations of certain terms used in this prospectus in connection with our Company and our business. The terms and their meanings may not correspond to standard industry meaning or usage of these terms.*

“active module”	A radio frequency module which amplifies and changes the frequencies of radio frequency signals and requires external power to operate. Examples include repeaters, trunk amplifiers, tower amplifiers and base station amplifiers
“base station”	The radio part of a cellular radio transmission site. A single base station usually contains several radio transmitters, receivers, control sections and power supplies. Base stations are sometimes called a land station or a cell site
“base station controller (BSC)”	A combination of device and software used by a base station to register call setup, call termination or transfer the cellular phone transmission from within a cell to an adjacent cell
“Code Division Multiple Access (CDMA)”	A system that allows multiple users to share one or more radio channels for service by adding a unique code to each data signal that is being sent to and from each of the radio transceivers. These codes are used to spread the data signal to a bandwidth much wider than is necessary to transmit the data signal without the code
“Code Division Multiple Access 2000 (CDMA2000)”	CDMA2000 is an evolved version of the CDMA system that uses wider bandwidth radio channels and enhanced packet transmission protocols to provide for advanced high-speed data services. The CDMA2000 system uses multiples of the standard radio channels. These multiples are 3, 6, 9 or 12 times the standard 1.25 MHz wide bandwidth. These wider bandwidths allow for user data transmission rates of up to 2 megabits per second
“combiner”	A device that is used to combine several channels onto a common transmission line or antenna system
“coupler”	A device that is used to transfer signal from one transmission medium to another transmission medium. A coupler may also be used to insert a signal from one transmission line to another transmission line
“dBi”	Decibel isotropic — the measurement of the forward gain of an antenna compared to a fictitious isotropic antenna, which uniformly distributes energy in all directions
“duplexer”	A combined filter device that permits a transmitter and receiver to share the same antenna assembly by using filters with different frequency bands. The use of a duplexer prevents transmitter power output to the antenna from transferring to sensitive receiver assembly

---

## GLOSSARY OF TECHNICAL TERMS

---

“fiber optic converter module”	A self-contained assembly of devices that changes one set of codes, modes, sequences or frequencies to a different set via optically transparent fiber through which light can be transmitted by successive internal reflections, installed as a unit
“filter”	A device that selectively transmits signals having certain properties (often, a particular range of wavelengths/frequencies), while blocking the remainder
“frequency band”	A section of the radio frequency spectrum defining a certain number of adjacent frequencies
“Gigahertz (GHz)”	One billion cycles per second, a measurement unit for frequency
“GPS”	Global Positioning System
“Global System For Mobile Communications (GSM)”	A digital cellular telephone system that originated in Europe and is now available in most parts of the world. The GSM system uses 200 kHz wide channels that are divided into frames that hold 8 time slots
“integrated module”	A collection of distinct elements or self-contained components that have been built into one single package
“ISO”	International Organization for Standardization
“ITU”	International Telecommunication Union
“Megahertz (MHz)”	One million cycles per second, a measurement unit for frequency
“passive module”	A radio frequency module that filters, combines and splits radio frequency signals. Examples include filters, duplexers, multi-frequency splitters and combiners
“Personal HandyPhone System (PHS)”	A lightweight portable wireless telephone that functions as a cordless phone in the home and as a mobile phone elsewhere
“power amplifier”	A device that amplifies and re-transmits signals, without significantly altering any characteristics of the incoming signal other than its amplitude
“radio frequency” or “RF”	Those frequencies of the electromagnetic spectrum normally associated with radio wave propagation. RF sometimes is defined as transmission at any frequency at which coherent electromagnetic energy radiation is possible
“receiver”	The portion of the communication system that includes a detector and signal processing electronics to convert electrical signals (electric waves) to audio or data signals. It provides reception and, if necessary, demodulation of electronic signals

---

## GLOSSARY OF TECHNICAL TERMS

---

“repeater”	An electronic device that receives a weak or low-level signal and retransmits it at a higher level or higher power, so that the signal can cover longer distances without degradation
“RoHS”	Directive on the Restriction of the Use of Certain Hazardous Substances in Electrical and Electronic Equipment 2002/95/EC
“second generation (2G)”	A term commonly used to describe the second technology used in a specific application or industry. In cellular telecommunications, 2G systems use digital radio technology with advanced messaging and data capabilities
“third generation (3G)”	A term commonly used to describe the third generation of technology used in a specific application or industry. In cellular telecommunications, third generation systems use wideband digital radio technology as compared to 2G narrowband digital radio
“Time Division Synchronous Code Division Multiple Access (TD-SCDMA)”	A 3G mobile standard developed in the PRC and approved by the International Telecommunication Union
“tower mount amplifier”	A device that uses a small amount of energy to control a larger amount of energy through the part of a transmission line that holds the conductors in place and off the ground
“transducer”	A device or substance that converts one type of energy to another for various purposes including measurement or information transfer
“trunk amplifier”	A device that uses a small amount of energy to control a larger amount of energy through a circuit between switchboards or other switching equipment
“UCS”	Universal Certification Service Co., Ltd.
“Wideband Code Division Multiple Access (W-CDMA)”	A 3G digital cellular system that uses radio channels and has a wider bandwidth than 2G digital cellular systems
“WiFi”	Wireless fidelity — a type of WLAN
“WiMax”	A standard for fixed broadband wireless metropolitan access networks that use point-to-multipoint architecture
“WLAN”	Wireless local-area network

---

## FORWARD-LOOKING STATEMENTS

---

This prospectus contains many statements that are “forward-looking”. You can identify these statements by the use of terms such as “believe,” “anticipate,” “expect,” “estimate,” “future,” “intend,” “may,” “ought to,” “plan,” “should,” “will,” negatives of such terms or other similar statements. You should not place undue reliance on any of these forward-looking statements. Although we believe our assumptions in making these forward-looking statements are reasonable, our assumptions may prove to be incorrect and you are cautioned not to place undue reliance on such statements. The forward-looking statements in this prospectus include, but are not limited to, statements relating to:

- our goals and strategies and our various measures to implement such strategies;
- our future business development, results of operations and financial condition;
- expected growth of and changes in the PRC telecommunication industry;
- projected revenues, profits, earnings and other estimated financial information;
- our ability to capture future market share in China;
- our ability to maintain strong relationships with our customers and suppliers;
- our planned use of proceeds;
- our ability to protect our intellectual property rights; and
- PRC government policies regarding the telecommunication industry.

The forward-looking statements included in this prospectus are subject to risks, uncertainties and assumptions about our businesses and business environments. These statements reflect our current views with respect to future events and are not a guarantee of future performance. Actual results of our operations may differ materially from information contained in the forward-looking statements as a result of many factors, including but not limited to the following:

- competition in the wireless communication industry;
- growth of, and risks inherent in, the wireless communication industry in China;
- our reliance on our key customers for our revenue;
- our ability to continuously keep up with changes in RF technology;
- maintaining the quality of our wireless coverage solutions;
- our ability to attract and retain qualified executives and personnel; and
- our ability to protect and enforce our intellectual property rights.

We undertake no obligation to publicly update or revise any forward-looking statements contained in this prospectus, whether as a result of new information, future events or otherwise, except as required by law and the Listing Rules. All forward-looking statements contained in this prospectus are qualified by reference to this cautionary statement.

---

## RISK FACTORS

---

*You should carefully consider all of the information set out in this prospectus before making an investment in the Offer Shares, including the risks and uncertainties described below in respect of our business and our industry and the Global Offering. You should pay particular attention to the fact that we are a company incorporated in the Cayman Islands and that our principal operations are conducted in China and are governed by a legal and regulatory environment that in some respects differs from what prevails in other countries. Our business, financial condition or results of operations could be affected materially and adversely by any of these risks.*

### RISKS RELATED TO OUR COMPANY

**Our business and results of operations are affected by economic cycles, including the recent global financial and economic crisis.**

Since the second half of 2008, the global financial system has experienced significant difficulties and disruptions, leading to reduced liquidity, greater volatility, widened credit spreads and a lack of price transparency in the global credit and financial markets. The difficulties in global credit and financial markets have also resulted in a widening global economic crisis. There are indications that the current financial and economic downturn may persist or worsen. The slowdown experienced in the economies of the United States, the European Union and certain Asian countries adversely affected the capital expenditures of the network providers in different countries, which we believe has consequentially affected the demand of our products. For example, one of our customers, Reliance, has significantly delayed or decreased its order with us in 2008 and 2009, while another customer, Nortel Networks, filed for protection from creditors under Chapter 11 of the United States Bankruptcy Code on January 14, 2009, both of which have resulted in a decline in our overseas sales. The decrease and slowdown in demand for mobile communication infrastructure equipment resulted from the global financial and economic crisis has put significant downward pressure on prices of antenna and base station RF subsystem products, which are our major source of sales revenues. There can be no assurance as to when the market for our products will recover and that we will not suffer a significant further downturn.

While various governments have announced efforts to increase liquidity in the financial markets and stimulus packages to slow or reverse the economic downturn, there can be no assurance that these measures will be successful. If the global economy continues to grow at a slower rate than expected, or experiences a recession, growth in demand for the mobile communication infrastructure products will also continue to slow down or decrease. As a result, our business, financial condition and results of operations would continue to be adversely affected. Our business model is very sensitive to the spending cycle of the communication network providers, and without a recovery in consumer usage, downward pressure on prices and demand for our products will persist.

## RISK FACTORS

**We rely upon a few customers for the majority of our revenues and the loss of any one of these customers, or a significant loss, reduction or rescheduling of orders from any of these customers, could have a material adverse effect on our business, results of operations and financial condition.**

We sell most of our products to a small number of customers with whom we have not entered into any long-term contracts, and we expect that this will continue. The following table sets forth our revenue attributable to sales to our major customers in absolute terms and as a percentage of our revenue for the periods specified:

	For the Year Ended December 31,						For the Eight Months Ended August 31,			
	2006		2007		2008		2008		2009	
	RMB	%	RMB	%	RMB	%	RMB	%	RMB	%
	(unaudited)									
	(in thousands, except percentages)									
<b>PRC Domestic</b>										
ZTE	166,757	46.2%	248,520	39.7%	237,314	35.4%	120,883	28.3%	231,864	36.7%
China Unicom	36,373	10.1%	18,331	2.9%	34,321	5.1%	6,291	1.5%	148,025	23.4%
China Mobile	39,961	11.1%	40,110	6.4%	37,127	5.5%	19,610	4.6%	56,947	9.0%
China Telecom	19,678	5.4%	9,857	1.6%	10,240	1.5%	592	0.1%	53,265	8.4%
Nokia (China) <sup>(1)</sup>	26,357	7.3%	46,779	7.5%	58,146	8.7%	47,756	11.2%	49,246	7.8%
Nortel Networks	8	—	1,287	0.2%	48,940	7.3%	46,009	10.8%	14,498	2.3%
NEC	348	0.1%	8,341	1.3%	18,816	2.8%	7,043	1.7%	13,770	2.2%
Alcatel-Lucent (China) <sup>(2)</sup>	691	0.2%	—	—	6,212	0.9%	2,638	0.6%	7,427	1.2%
China Netcom	605	0.2%	1,511	0.2%	490	0.1%	—	—	—	—
UTStarcom	19,701	5.4%	6,464	1.0%	1,401	0.2%	1,017	0.2%	27	—
Others	8,773	2.4%	12,071	1.9%	13,313	2.0%	9,339	2.2%	6,003	0.9%
<b>Overseas</b>										
Nokia (overseas) <sup>(1)</sup>	25,492	7.1%	112,494	17.9%	102,687	15.3%	87,522	20.5%	41,156	6.5%
ITI (India)	13,905	3.9%	3,727	0.6%	1,802	0.3%	367	0.1%	4,594	0.7%
Nortel Networks (overseas)	—	—	3,280	0.5%	14,365	2.1%	11,015	2.6%	1,444	0.2%
Alcatel-Lucent (overseas) <sup>(2)</sup>	—	—	—	—	1,233	0.2%	828	0.2%	1,012	0.2%
Reliance (India)	—	—	107,439	17.2%	77,540	11.5%	59,666	14.0%	—	—
Others	2,307	0.6%	6,595	1.1%	7,235	1.1%	5,862	1.4%	3,089	0.5%
<b>Total</b>	<u>360,956</u>	<u>100.0%</u>	<u>626,806</u>	<u>100.0%</u>	<u>671,182</u>	<u>100.0%</u>	<u>426,438</u>	<u>100.0%</u>	<u>632,367</u>	<u>100.0%</u>

Notes:

- (1) The figures represent sales to Nokia Siemens Networks after Nokia's merger with Siemens in early 2007.
- (2) The figures include sales to Lucent prior to Lucent's merger with Alcatel in 2006.

We depend on the continued purchases of our products by a small number of our customers, and any fluctuations in demand from such customers or other customers could negatively affect our results of operations. If we are unable to broaden our customer base and expand relationships with major network solution providers and major network operators, our business may continue to be affected by unanticipated demand fluctuations due to our dependence on a small number of customers.

---

## RISK FACTORS

---

Further, certain of our Directors and Beneficial Owners also have an indirect interest in ZTE. The following diagram illustrates the shareholding structure of ZTE with respect to certain of our Directors and Beneficial Owners as of the Latest Practicable Date:

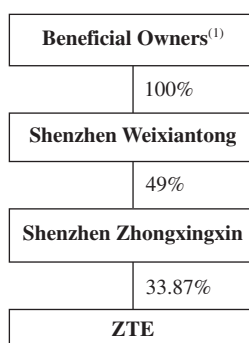

*Note:*

- (1) Each of the Beneficial Owners holds the same percentage of shareholding interest in Fangyi Holdings and Shenzhen Weixiantong.
- Our non-executive Director, Qu Deqian, has been one of ZTE's five supervisors since 2005. Qu Deqian was, during the period from June 2003 to January 2007, a director of Shenzhen Kanquan Electromechanical Company, a group company of ZTE, and has since March 2002 been a supervisor of Shenzhen Guoxin Electronic Development Co., Ltd., which is owned by ZTE as to 90% and by ZTE Kangxun Telecom Company, Limited as to 10%.
  - Zhou Susu, the spouse of Hu Xiang, has been the senior vice president of ZTE between 1999 and 2008 and currently a director of ZTE's wholly-owned subsidiary, ZTE (H.K.) Limited.
  - As of the Latest Practicable Date, the Beneficial Owners had an indirect equity interest of approximately 16.6% in ZTE through their shareholdings in Shenzhen Weixiantong. Shenzhen Weixiantong owns 49% shareholding interest in Shenzhen Zhongxingxin, which in turn had approximately 33.87% shareholding interest in ZTE as of the Latest Practicable Date.
  - Our Directors, Hu Xiang, Xing Qibin and Qu Deqian, are members of the Beneficial Owners and together held approximately 5.60% shareholding interests in Shenzhen Weixiantong as of the Latest Practicable Date. Therefore Hu Xiang, Xing Qibin and Qu Deqian have indirect shareholding interests in ZTE through their shareholding interests in Shenzhen Weixiantong.
  - The direct and indirect equity interests of the Beneficial Owners in ZTE are minimal and diverse and do not render ZTE a connected person of our Group for the purpose of the Listing Rules. See "Our Relationship with Certain Customers and Suppliers — Our Relationship with Certain Customers" for further details regarding our relationship with ZTE.

Unanticipated demand fluctuations can have a negative effect on our revenues and business, and an adverse effect on our results of operations and financial condition. In addition, our dependence on a small number of major customers exposes us to numerous other risks, including:

- a slowdown or delay in deployment of wireless networks by any one customer could significantly reduce demand for our products;

---

## RISK FACTORS

---

- reductions in a single customer's forecasts and demand could result in excess inventories;
- consolidation of customers can reduce demand as well as increase pricing pressure on our products due to increased purchasing leverage;
- each of our customers has significant bargaining leverage over us to require changes in sales terms including pricing, payment terms and product delivery schedules;
- a customer could compete with us directly should it decide to increase its level of internal design and manufacturing capability of wireless communication network products;
- loss of a single customer's business could result in a significant loss of revenue; and
- we face significant credit risk as a result of the significant concentration of our accounts receivable, which could have a material adverse effect on our liquidity and financial condition if one of our major customers declared bankruptcy or delayed payment of our accounts receivables.

**We generally do not enter into long-term contracts with our customers.**

Consistent with common practice in the markets in which we operate, and due to factors such as fluctuations in price, supply and demand in the wireless communication network infrastructure industry as well as our customers' need for flexibility in volume, types of products and price terms, we generally do not enter into long-term contracts with our customers. As we do not enter into long-term contracts with our customers, there can be no assurance that we will maintain or increase our sales to our customers at current levels or at all. Any loss to competitors of a significant portion of our current sales to any of our major customers could have a material adverse effect on our business, financial condition and results of operations.

**Failure by the wireless telecommunication sector in China to maintain its current pace of growth could materially and adversely affect our profitability and future prospects.**

We generated most of our revenue from sales of antenna systems and RF devices in China. The continued growth of the PRC wireless communication industry is essential to our business growth prospects and future success. If the development of the wireless communication industry in China slows or our customers' expenditures on antenna systems and RF devices decrease, the market demand for our antennas and RF devices could be negatively affected. Similarly, our profitability and future prospects for our business could be materially and adversely affected if the PRC government or other relevant regulatory authorities are not able to allow construction of new wireless communication networks, or terminate, delay or suspend construction or extension of new or existing wireless communication networks.

**If we cannot continue to rapidly develop, manufacture and market innovative products and services that meet customer requirements for performance and reliability, we may lose market share and our revenue may suffer.**

The process of developing new wireless communications network infrastructure products and services is complex and uncertain, and failure to anticipate customers' changing needs and emerging technological trends accurately and to develop or obtain appropriate intellectual property could significantly harm our results of operations. We must make long-term investments and commit significant resources before knowing whether our investments will eventually result in products that the market will accept. After a product is developed, we must be able to manufacture sufficient volumes quickly and at low cost. To accomplish this, we must accurately forecast volumes, product mix and configurations that meet customer requirements, which we may not be able to do successfully. Further, rapid technology advancement in the wireless communication industry could render our products or inventories obsolete and result in material write-downs in our inventory. For example, PHS protocol is becoming outmoded due to limited bandwidth and coverage area compared to other protocols developed under the 3G standard.

---

## RISK FACTORS

---

For the years ended December 31, 2006, 2007, 2008 and the eight months ended August 31, 2009, our research and development expenditures were approximately RMB15.2 million, RMB24.9 million, RMB34.6 million and RMB21.3 million, respectively, representing approximately 4.2%, 4.0%, 5.1% and 3.4% of our revenue during the periods, respectively.

Our efforts target the research and development of new products in each of our product groups. For example, we have developed new products to support a number of 3G transmission protocols, including China's new 3G protocol, TD-SCDMA, and other emerging network technologies, such as WiMax. Our research and development efforts also target ways to increase the manufacturing efficiency of our existing products, reduce the cost to our customers, and increase our profitability. The technological sophistication and innovative ideas of our research and development personnel have enabled us to obtain 122 registered patents and file 38 pending patent applications with the Patent Office of the SIPO, PRC as of the Latest Practicable Date.

Among the factors that make the transition from current products to new products difficult are delays in product development or manufacturing, variations in product costs, and variations in customer demand for a new product. Our revenues and gross margins may suffer if we cannot make such a transition effectively; and they may also be negatively affected by the timing of product or service introductions by our suppliers and competitors. This is especially challenging when a product has a short life cycle or a competitor introduces a new product just before our own product introduction. Furthermore, sales of our new products may replace sales of some of our current products, offsetting the benefit of even a successful product introduction. If we incur delays in new product introductions, or do not accurately estimate the market effects of new product introductions, future demand for our products and our revenues may be seriously harmed due to the competitive nature of our industry.

**If we lose our ability to design customized products and solutions to meet our customers' requirements, our reputation and relationships with our customers may be damaged and we may incur significant warranty costs or other liabilities, any of which may materially and adversely affect our revenue growth.**

Our products and solutions are designed with significant investment of time and expertise to employ complex technology so that not only industry and government standards but also customers' specifications can be adequately addressed. If we are unable to continue to meet these standards and specifications, we may be disqualified by our customers to continue to provide our products and solutions. If we are unable to maintain the quality and design standards of our RF products and solutions, our reputation and relationships with existing and prospective customers may be damaged, which could have a material and adverse effect on our revenue growth, the prices we charge for our products and solutions and our profitability.

**Sales of our RF products and solutions may decrease as a result of our failure to develop commercially successful or viable RF products and solutions.**

The wireless communications network infrastructure equipment market is characterized by frequent improvements in RF products and solutions as a result of rapid technological change, evolving industry standards and transmission protocols and intense competition. In order to remain competitive, we must continually improve our current RF products and solutions and develop and introduce new or enhanced products with competitive functionality, performance, quality and price to adequately satisfy our customers' requirements. We plan to continue to invest considerable time and resources to enhance and develop new RF technology, including the development of more advanced 3G products. However, we cannot provide assurance that our past success in developing RF products will result in successful development of new or enhanced RF products that are commercially viable. As 3G technology is new and evolving, we cannot provide any assurance that our research and development efforts will yield RF products that are readily deployable in 3G networks or that our

---

## RISK FACTORS

---

customers will be satisfied with the performance of our 3G products. Under those circumstances, we will be unable to realize the economic benefits of our research and development efforts, we may not be able to serve our customers' 3G needs, and our customers may not wish to continue to purchase our RF products and solutions.

**We are subject to risks related to product defects that could result in product recalls and could subject us to warranty claims that are greater than anticipated. If we were to experience a product recall or an increase in warranty claims that exceed our forecast, our sales and operating results could be adversely affected.**

We test our products through a variety of means before shipment. We typically also provide a one to two year warranty for free repair or replacement of any defective products. Certain customers may also separately negotiate with us for longer warranty periods. Product warranty costs are recognized as expenses in the consolidated statements of comprehensive income in the period in which they are incurred. As product warranty costs had not been significant during 2006, 2007, 2008 and the eight months ended August 31, 2009, we did not make any provision for product warranties during 2006, 2007, 2008 and the eight months ended August 31, 2009. There can be no assurance that our testing will reveal all latent defects in our products, which may not become apparent until after the products have been sold into the market. Accordingly, while we have not had any product recall or third party claim for any damage or loss sustained arising from defective products during 2006, 2007, 2008 and the eight months ended August 31, 2009, there is a risk that product defects may occur, which could require a product recall. Product recalls can be expensive to implement and, if a product recall occurs during the product's warranty period, we may be required to replace the defective product. In addition, a product recall may damage our reputation and relationship with our customers, and we may lose market share with our customers.

**If we fail to effectively implement our production plan, our results of operations may be materially and adversely affected.**

We plan our production primarily based on our projected orders from our customers. However, we cannot guarantee that our internal projections of demand for our products are accurate. If our projections for orders are inaccurate, we may build up inventories of our RF products in excess of actual demand. If we fail to effectively implement our production plan during any particular period, our results of operations for that period may be materially and adversely affected.

**Our failure to acquire raw materials or to fill our customers' orders in a timely and cost-effective manner could materially and adversely affect our business operations.**

We rely on third-party suppliers to meet our raw material requirements. During 2006, 2007, 2008 and the eight months ended August 31, 2009, purchases from our five largest raw material suppliers together accounted for approximately 37.2%, 33.0%, 31.3% and 26.8% of our total purchases of raw materials, respectively, while the largest raw material supplier accounted for approximately 22.0%, 17.8%, 10.4% and 7.9% of our total purchases of raw materials, respectively. If any of our major suppliers is unable to deliver raw materials in the time required for production, and we fail to meet our raw material requirements with purchases from other suppliers in a timely and cost-effective manner, our provision of wireless communication network RF equipment and coverage extension solutions to our customers could be delayed. In addition, we may be required to purchase RF components or modules in the market at higher prices to meet our production deadlines if the delivery of raw materials is delayed. Our relationships with our customers could be adversely affected as a result of any such delays or cost increases, which may materially and adversely affect our business operations.

---

## RISK FACTORS

---

### **Our suppliers, contract manufacturers or customers could become competitors.**

Many of our customers have the capability to internally design and/or manufacture their own wireless communications network products. These customers also continually evaluate whether to manufacture their own wireless communications network RF equipment or utilize contract manufacturers to produce their own internal designs. In the event that our customers manufacture or design their own wireless communications network RF equipment, such customers could reduce or eliminate their purchases of our products, which would result in reduced revenues and would adversely affect our results of operations and liquidity. Wireless network solution providers with internal manufacturing capabilities, including many of our customers, could also sell wireless communications network RF equipment externally to other manufacturers, thereby competing directly with us. In addition, our suppliers or contract manufacturers may decide to produce competing products directly for our customers and, effectively, compete against us. If, for any reason, our customers produce their wireless communications network RF equipment internally, increase the percentage of their internal production, require us to participate in joint venture manufacturing with them, engage our suppliers or contract manufacturers to manufacture competing products, or otherwise compete directly against us, our revenues could decrease, which would adversely affect our results of operations.

### **A substantial portion of our sales is made outside the PRC. Conducting business in international markets involves risks and uncertainties such as foreign exchange rate exposure and political and economic instability that could lead to reduced international sales and reduced profitability associated with such sales.**

A significant portion of our sales is made outside the PRC. Our overseas sales principally consist of our direct sales to overseas networks operators (such as Reliance in India) and overseas factories or inventory hubs of global network solution providers (such as Nokia Siemens Networks headquartered in Finland). We also sell to distributors in Vietnam and Indonesia. For 2006, 2007, 2008 and the eight months ended August 31, 2009, our overseas sales were approximately RMB41.7 million, RMB233.5 million, RMB204.9 million and RMB51.3 million, respectively. We anticipate that international sales will continue to represent a significant portion of our total sales and that continued growth and profitability will require further international expansion. Identifiable foreign exchange rate exposures result primarily from currency fluctuations, accounts receivable from customer sales and the anticipated purchase of products from third party suppliers. International business risks also include political and economic instability, tariffs and other trade barriers, longer customer payment cycles, burdensome taxes, restrictions on the repatriation of earnings, expropriation or requirements of local or shared ownership, compliance with local laws and regulations, terrorist attacks, developing legal systems, reduced protection of intellectual property rights in some countries, cultural and language differences, difficulties in managing and staffing operations and difficulties in maintaining good employee relations. We believe that international risks and uncertainties could lead to reduced international sales and reduced profitability associated with such sales, which would reduce our overall sales and profits.

### **We have experienced, and will continue to experience, significant fluctuations in sales and operating results from period to period.**

Our results fluctuate from period to period due to a number of factors, including:

- network operators' decisions and timing on development of network infrastructure;
- the lack of any obligation by our customers to purchase their forecasted demand for our products;
- variations in the timing, cancellation, or rescheduling of customer orders and shipments;

---

## RISK FACTORS

---

- high fixed expenses that increase operating expenses, especially during a period with a sales shortfall;
- product failures and associated warranty and other additional costs; and
- discounts given to certain customers for large volume purchases.

Our major customers generally have no obligation to purchase forecasted amounts and may cancel orders, change delivery schedules or change the mix of products ordered with minimal notice and without penalty. As a result, we may not be able to accurately predict our quarterly sales. Because our expense levels are partially based on our expectations of future sales, our expenses may be disproportionately large relative to our revenues, and we may be unable to adjust spending in a timely manner to compensate for any unexpected revenue shortfall. Any shortfall in sales relative to our quarterly expectations or any delay of customer orders would adversely affect our revenues and results of operations.

Order deferrals and cancellations by our customers, declining average sales prices, changes in the mix of products sold, delays in the introduction of new products and longer than anticipated sales cycles for our products have, in the past, adversely affected our results of operations. Despite these factors, we, along with our contract manufacturers, maintain significant finished goods, work-in-progress and raw materials inventory to meet estimated order forecasts. If our customers purchase less than their forecasted orders or cancel or delay existing purchase orders, there will be higher levels of inventory that face a greater risk of obsolescence. If our customers desire to purchase products in excess of the forecasted amounts or in a different product mix, there may not be enough inventory or manufacturing capacity to fill their orders.

Due to these and other factors, we have experienced significant fluctuations in sales and operating results from period to period, which fluctuations have not been seasonal. Our past results are not reliable indicators of our future performance. Future revenues and operating results may not meet the expectations of public market analysts or investors. In either case, the price of our ordinary shares could be materially adversely affected.

**The initial vendor qualification cycle associated with the sales of our products is typically lengthy, often lasting from six months to a year, which could cause delays in forecasted sales and cause us to incur substantial expenses before we record any associated revenues.**

Our customers normally conduct significant technical evaluations and qualifications of our products before making purchase commitments. We believe this qualification process involves a significant investment of time and resources from both our customers and us in order to ensure that our product designs are fully qualified to perform as required. The qualification and evaluation process may take longer than initially forecasted, thereby delaying the shipment of sales forecasted for a specific customer for a particular quarter and causing our operating results for the quarter to be less than originally forecasted. Such a sales shortfall could reduce our profitability and negatively affect our results of operations.

**Our key managerial and technical personnel are critical to the success of our business and if we fail to attract or retain such personnel we may compromise our ability to maintain strong relationships with customers and suppliers, develop new products and effectively carry on our research and development and other efforts.**

We largely depend on the efforts and abilities of our Directors and senior management, particularly Hu Xiang, Wang Guoying, Shao Zhiguo and Yan Andrew Y., and other senior technical staff for our future growth and success, due to the years of industry experience and technical knowledge they bring to us. Hu Xiang, Wang Guoying, Shao Zhiguo and Yan Andrew Y. comprise the group of individuals serving on the board of directors or in senior management of each member of our Group during 2006, 2007, 2008 and the eight months ended August 31, 2009 and up to the time of Listing. They constitute the core management group responsible for the results of our Group during

---

## RISK FACTORS

---

2006, 2007, 2008 and the eight months ended August 31, 2009. Certain of our Directors and Beneficial Owners also maintain certain relationship with certain of our customers and suppliers. See “Our Relationship with Certain Customers and Suppliers”. We are also substantially dependent on qualified technical, marketing and engineering personnel with a thorough understanding of local conditions. We also rely on our research and development engineers with advanced degrees or senior engineer certificates for the operation of our research and development function and manufacturing facilities. The technological sophistication and innovative ideas of our research and development personnels have enabled us to obtain 122 registered patents and file 38 pending patent applications in the PRC as of the Latest Practicable Date. Our employment agreements with these individuals have an initial term of one year subject to a right of termination under specified circumstances, such as a material breach of their contractual obligations. Our future growth and success may be compromised if we are unable to attract or retain qualified senior management. Similarly, the loss of senior technical staff may result in the deterioration of the quality of our wireless network coverage solutions and our ability to develop and produce our products. If we lose the services of our key management or any other senior technicians or engineers, our operations will be negatively affected.

The wireless coverage industry in China has experienced a high level of employee mobility. Competition for experienced RF technology experts is intense. In 2006, 2007, 2008, and the eight months ended August 31, 2009, the turnover rate of our research and development engineers was approximately 9.2%, 8.8%, 6.4% and 6.3%, respectively, calculated as the number of our research and development engineers departed during the period divided by the number of our research and development engineers departed during the period together with the total number of research and development engineers at the end of the period. Few senior-level research and development or technical personnel are available for hire and the costs of hiring and retaining such individuals are relatively high. We also believe that in order to continue to be successful, we must strengthen our ability to attract and retain senior, experienced and qualified managerial and technical personnel. We cannot assure the investors that such personnel will remain with us once hired.

**The selling prices of our earlier products have decreased over time, and we anticipate that the selling prices for our existing products may decrease over time. If we cannot supplement our product portfolio with new products that have higher selling prices or lower the production costs of our products, our gross margin will decline.**

Wireless network operators are continuing to place pricing pressure on wireless infrastructure builders, including wireless network solution providers and coverage extension solution providers, which in turn, has resulted in lower selling prices for our existing products, with certain competitors aggressively reducing prices in an effort to increase their market share. In addition, the consolidation of wireless network solution providers, such as the merger of Alcatel and Lucent and of Nokia and Siemens, has concentrated the purchasing power at fewer surviving entities, which is placing further pricing pressures on the products we sell to such customers. We may be forced to further reduce our prices to such customers, which would have a negative effect on our business and results of operations. We believe that the selling prices of our existing products will continue to decline for the foreseeable future. Since wireless infrastructure builders frequently negotiate supply arrangements far in advance of delivery dates, we must often commit to price reductions for our products before we know how, or if, we can obtain such cost reductions. With ongoing consolidation in our industry, the increased size of many of our customers allows them to exert greater pressure on us to reduce prices. In addition, the selling prices of our products are affected by price discounts negotiated without firm orders for large volume purchases by certain customers. To offset the declining selling prices of our existing products, we must reduce manufacturing costs and ultimately develop new products with higher selling prices. If we cannot achieve such cost reductions or increases our average selling prices, our gross margins will decline.

---

## RISK FACTORS

---

**We may experience delays or defaults in collecting trade receivables from our customers, which may adversely affect our cash flow and working capital, financial condition and operating results.**

We recorded a significant amount of trade and note receivables at the end of each reporting period during 2006, 2007, 2008 and the eight months ended August 31, 2009. As of December 31, 2006, 2007, 2008 and August 31, 2009, our trade and note receivables amounted to approximately RMB199.5 million, RMB264.4 million, RMB347.8 million and RMB500.4 million respectively, representing approximately 66.0 %, 48.3%, 52.8 % and 54.6% of our total current assets as at the respective balance dates. For details on the aged analysis of trade receivables, please refer to the accountants' report set out in Appendix I to this prospectus. As of October 31, 2009, approximately RMB151.3 million of the RMB312.7 million trade receivables outstanding as of August 31, 2009 had been settled.

In the event of any further delays or any material portion of such trade note receivables becomes bad debts and cannot be collected by us, our operations and financial condition may be adversely affected.

**The non-transferrability of the property right in one of the properties we own may undermine our ownership interest.**

Property numbered one, as set out in the Property Valuation Report, is our principal place of business in the PRC, which is being used for manufacturing, office, research and development purposes. The aggregate gross floor area of this property is approximately 16,411.98 sq. m., and no commercial value has been assigned to this property as of September 30, 2009. As advised by our legal advisers as to PRC laws, the land use rights and the building ownership rights of this property cannot be transferred or leased and cannot be pledged as security without pre-approval from Shenzhen Land Bureau. In the event that Shenzhen Land Bureau withholds its approval on the pledge of this property, our ability to pledge this property as security for financing purpose will be restricted, and our ownership interest will be undermined.

**Our operations may be disrupted due to our landlords' lack of the relevant title certificates as to certain leased properties**

As of the Latest Practicable Date, we leased a total of eleven properties in the PRC, five of which were for manufacturing use (namely properties numbered 4, 9, 12, 13 and 14 of the Property Valuation Report), six were used as dormitories (namely properties numbered 5, 6, 7, 8, 10 and 11 of the Property Valuation Report). We have been advised by our legal advisers as to PRC laws that (a) the respective landlords of seven of such leased properties (namely properties numbered 4, 5, 6, 7, 8, 9 and 10 of the Property Valuation Report) have not yet obtained the relevant building ownership certificates or provided construction project planning permits or other proof of ownership to our Group, (b) two of the seven leased properties that lack both building ownership certificates or other proof of ownership are used by us as factories (namely properties numbered 4 and 9 of the Property Valuation Report) and the other five are used as dormitories (namely properties numbered 5, 6, 7, 8 and 10 of the Property Valuation Report), and (c) among the seven leased properties, five tenancy agreements with respect to properties numbered 5, 6, 7, 8 and 10 of the Property Valuation Report have not been registered or filed with the relevant housing authorities in the PRC. Accordingly, our legal advisers as to PRC laws are unable to confirm if these landlords have the lawful right to lease the relevant properties to us. The lack of the relevant building ownership certificates or other proof of ownership, may, however, result in the invalidity of the respective tenancy agreements and us not being able to defend our leasehold interests against any third party who subsequently enforce their rights to the properties with support from the PRC courts or relevant government authorities. Furthermore, as advised by our legal advisers as to PRC laws, we may be exposed to payment to the relevant PRC housing authorities of a fine not exceeding RMB294,004, which is equal to 10% of total rental amount in the event that it has been determined as our fault in causing the non-registration of the relevant lease agreements.

---

## RISK FACTORS

---

Two of the seven leased properties for manufacturing use (namely properties numbered 4 and 9 in the Property Valuation Report) are without building ownership certificates or other proof of ownership from the landlords. These two leased properties have a total gross floor area of approximately 14,970 square meters, representing approximately 16.2% of the total gross floor area used for production by us. These two leased properties will be relocated and combined to a new centralized premise by the end of 2009. For details, please refer to the section headed “Real Property — recent lease renewals and relocation of our manufacturing facilities.”

In the event that we need to relocate any leased premises as a result of our landlords’ lack of the relevant title certificates, our Directors consider that we will be able to relocate our dormitories and factories to alternative premises without incurring significant costs and time; nor will such relocation disrupt our operation. Our Directors also consider that any relocation of our manufacturing premises can be completed within a reasonable period of time and without significant disruption of our operation or incurrence of additional costs. In the event of any delay in our relocation of manufacturing premises beyond a reasonable period of time, our operation may be disrupted and our profitability may be materially and adversely affected.

**Our lack of comprehensive intellectual property rights may undermine our competitive position, and litigation to protect our intellectual property rights or to defend against third-party allegations of infringement may be costly.**

While we have 122 registered patents and 38 pending patent applications with the Patent Office of the SIPO as of the Latest Practicable Date, we have not obtained any intellectual property rights outside of the PRC. We continue to rely significantly on trade secret protections and employee and third party confidentiality agreements to safeguard our intellectual property. Because only limited protection is afforded under these protections and agreements, we may not be able to take adequate actions to protect our intellectual property rights. Third parties may infringe or misappropriate our proprietary technologies or other intellectual property rights and cause a material and adverse effect on our business, financial condition or operating results. It could be difficult and expensive to police unauthorized use of proprietary technology. Our ability to protect our intellectual property may be compromised in the event that any of our management members or employees in possession of our confidential proprietary information leaves us. Also, we may be required to litigate in order to protect our trade secrets or determine the validity and scope of the proprietary rights of others. We cannot assure you that the outcome of such potential litigation will be in our favor. Litigation may be costly and may divert management attention and other resources away from our business. An adverse determination in any such litigation against us will impair our intellectual property rights and may harm our business, prospects and reputation. In addition, we would have to bear all costs arising from such litigation if we are unable to recover them from other parties. The occurrence of any of the foregoing could have a material adverse effect on our business, results of operations and financial condition.

**We may be exposed to infringement or misappropriation claims by third parties, which, if determined adversely to us, could cause us to pay significant damage awards.**

Our success also depends largely on our ability to use and develop our technology and know how without infringing the intellectual property rights of third parties. The validity and scope of claims relating to RF technology patents involve complex scientific, legal and factual questions and analysis and, therefore, may be highly uncertain. We may also be subject to litigation involving claims of violation of intellectual property rights of third parties, even in situations where we have not in fact infringed on a third party’s intellectual property. The defense and prosecution of intellectual property suits, patent opposition proceedings and related legal and administrative proceedings can be both costly and time consuming and may significantly divert the efforts and resources of our technical and management personnel. If adversely determined against us in any such litigation or proceedings, we could be subject to significant liability to third parties. As a result, we may be required to seek licenses

---

## RISK FACTORS

---

from third parties, to pay ongoing royalties and to redesign our RF products. We could also be subject to injunctions prohibiting the manufacture and sale of our RF products or the use of our technologies. Protracted litigation could also result in our customers or potential customers deferring or limiting their purchase or use of our RF products until resolution of such litigation.

**We generally do not carry product liability insurance for our RF products and solutions, and any significant product liability claim could have a material and adverse effect on our financial condition.**

We generally do not carry product liability insurance for our RF products and solutions, any business interruption insurance, any third-party liability insurance for personal injuries or any environmental damage insurance for environmental emissions or accidents on our properties or relating to our operations. Therefore, any product liability claims against us in relation to our RF products and solutions, or any major interruptions of our operations or third-party claims could have a material and adverse effect on our financial condition.

### RISKS RELATED TO OUR INDUSTRY

**Failure of commercialization of 3G services, particularly TD-SCDMA technology in China or globally, could materially and adversely affect our profitability and future prospects.**

Significant capital investment by PRC telecommunication operators, including investments in wireless coverage solutions will be required to complete the deployment of 3G networks in China. We expect our products that are related to the 3G standard to command higher gross profit margins than our products that are related to the 2G standard. However, we cannot assure you that the 3G services will be adopted by the consumers in mass. In particular, TD-SCDMA technology is currently adopted by only one network operator, China Mobile. Failure of commercialization of 3G services, particularly TD-SCDMA technology in China or globally, could materially and adversely affect our profitability and future prospects.

**The telecommunications industry has experienced significant consolidation and this trend is expected to continue. Any disruption in our direct business relationship with any of our major customers as a result of market consolidation will adversely affect our sales and profitability.**

Consolidation in the telecommunications industry could result in delays in purchasing decisions by merged companies or in us playing a decreased role in the supply of products to the merged companies. Delays or reductions in wireless communications network infrastructure spending could have a material adverse effect on demand for our products. We depend on several large wireless network solution providers and network operators for a significant portion of our business. Recent examples of the consolidation includes China Telecom's acquisition of the CDMA network from China Unicom, through a series of transactions starting from June 2, 2008, China Netcom's merger with and into China Unicom on October 6, 2008 and Nortel Networks' filing for protection from creditors under Chapter 11 of the United States Bankruptcy Code on January 14, 2009. We have had to adjust our sales tactics following each of these events as our customers changed their purchase method, preference or the specifications of the products they desire. Any disruption in our relationships with our major customers could adversely affect our sales, operating margins, net income and share price.

---

## RISK FACTORS

---

**The competitive bidding process in the telecommunication infrastructure industry can result in our revenues fluctuating significantly from period to period.**

Contracts with the network operators in China and many regions overseas are awarded through a competitive bidding process. PRC domestic network operators generally award a larger amount of the contracts to providers that submitted the most favorable bids. We submit bids to sell our products directly to PRC domestic network operators for deployment into the networks they are constructing. Wireless network solution providers, such as our customers ZTE and Nokia Siemens Networks, also incorporate our products into their wireless coverage solutions, such as their proprietary base stations, in the bids they submit to the network operators. Other than through the bidding process, we have limited bargaining power with the network operators, as selections are made based on objective criteria and we have a number of competitors in China. If we or any one or more of our major customers failed to submit a competitive bid, it can have a negative effect on our revenues until the next bidding cycle which would have an adverse effect on our results of operations and financial conditions.

**Our success is tied to the growth of the market for wireless communications services and our future revenue growth is dependent upon the expected increase in the size of this market.**

Our revenues come from the sale of antennas and base station RF subsystems. Our future success depends upon the growth in demand for wireless communications services. However, wireless communications services may not grow at a rate fast enough to create demand for our products. While we benefited from significant demand in the eight months ended August 31, 2009, we believe PRC domestic network operators reduced or delayed capital spending on network construction in 2006, 2007 and most of 2008 in anticipation of 3G deployment. We cannot assure you the PRC domestic network operators would not reduce or delay their capital spending again in the future. Such reduced spending on wireless networks had a negative effect on our operating results. If wireless communications network operators delay or reduce levels of capital spending, our operating results could be negatively affected. Further, a reduction in capital spending budgets by network operators and wireless network solution providers caused by an economic downturn could also lead to a softening in demand for our products and services, which could result in a decrease in our revenues and earnings.

**The wireless communication industry in China is extremely competitive and our inability to compete effectively would be detrimental to our current business and prospects for future growth.**

We are in an extremely competitive industry, which is characterized by rapid technological advancement, downward pricing trends over the life cycle of a solution and high working capital requirements. We primarily compete on the following bases:

- design capability for wireless network infrastructure;
- quality of RF products;
- implementation capability;
- after-sales service;
- pricing and payment terms; and
- relationships with network operators.

However, there can be no assurance that we will maintain our competitiveness in these areas. If we fail to develop new products and services, periodically enhance our existing products and services, or otherwise compete successfully, it would reduce our sales and adversely affect our future prospects. In addition, China's entry into the World Trade Organization in 2001 has resulted in the gradual lifting of its import restrictions, lowering of import tariffs and relaxing of foreign investment restrictions.

---

## RISK FACTORS

---

Several foreign wireless equipment companies, such as Andrew and Powerwave, have entered into the PRC market. Many of these companies are significantly larger and financially stronger than us, and have established manufacturing facilities in the PRC trying to lower their production costs. This has further intensified price competition and may in the future affect our profit margins. Our current business and prospects for future growth would be materially and adversely affected if we are unable to compete effectively in the future.

**Our business may be subject to various regulatory restrictions, and any new regulation may restrict our methods of conducting business and subject us to severe penalties.**

Our antennas system, base station RF subsystem and coverage extension solution products are manufactured based on the designs, specifications or requirements set forth by our network operator and network solution provider customers. Our network operator and solution provider customers, in turn, base their designs and specifications on the laws and regulations governing the networks they are constructing. While we have ensured our manufacturing and research and development operations are in compliance with the environmental protection and safety laws and regulations issued by the central, provincial and local governments of the PRC, we cannot assure you that our network operator and solution provider customers will not change their designs and specifications as they begin to construct new networks in different parts of the world, or no government authority will change the relevant laws or regulations applicable to the designs and specifications of the equipment used in the networks located in their respective jurisdiction. For instance, in February 2003, the European Union issued the directive on restriction on hazardous substances, or RoHS, to exercise control over the toxic and hazardous materials used in certain electronic products. We believe some of our customers changed the design and specifications of the products they ordered from us in order to comply with the RoHS directive. If we cannot continue to design and manufacture products that are in compliance with the specifications set forth by our customers, our sales and operating results could be adversely affected.

Furthermore, the PRC government exercises considerable control over the structure and overall development of the telecommunication industry in China. It also owns a substantial percentage of all major telecommunication operators in China. The MII is the primary central government agency responsible for regulating the PRC wireless communication industry and has broad discretion and authority. The MII has adopted, and may adopt in the future, regulations that impose stringent standards on the wireless communication industry in China, with which we must comply. In order to comply with new regulations or revisions of previously implemented regulations we may be required to change our business plan, increase our costs or limit our ability to sell our RF products and solutions. If we are not able to comply with these regulations, we would be subject to various penalties, including fines and suspension or discontinuation of our operations. Therefore, adoption of new laws or regulations by the PRC government or a change in or revision of the interpretation of existing laws or regulations may also negatively affect our business prospects.

**Actual or perceived health risks from the electromagnetic fields generated by base stations and mobile devices could negatively affect our operations by leading regulatory authorities to impose more stringent telecommunication equipment standards or causing consumers to reduce their use of mobile devices.**

There has been public speculation about possible health risks to individuals from exposure to electromagnetic fields from base stations and from the use of mobile phone handsets. However, as of the Latest Practicable Date, we have not received any health related claims from existing or ex-employees for having been exposed to the electromagnetic fields during their employment. Research into these issues is ongoing by government agencies, international health organizations and other scientific bodies in order to develop a better scientific and public understanding of these issues. We cannot assure you that future results of these and other studies, irrespective of their scientific basis, will not suggest a link between electromagnetic fields and adverse health effects that could adversely affect our revenue and share price.

---

## RISK FACTORS

---

Although our RF products and wireless coverage extension solutions are designed to meet all relevant safety standards in China, no more than a perceived risk of adverse health effects of mobile communications devices could adversely affect us through increased difficulty in obtaining sites for base stations, the development of more stringent telecommunication equipment standards by local governments and a reduction in use of mobile devices by consumers. Most of our revenue is derived, either directly or indirectly, from the provision of antenna systems and RF devices and development of more stringent telecommunication electromagnetic field emissions standards could require us to allocate more funds and personnel to comply with any new standards. A reduction in the use of mobile devices by consumers could also result in a reduction of orders from our customers to initiate new wireless coverage extension solutions resulting in a negative effect on our financial results and share price.

### **RISKS RELATED TO OUR OPERATIONS IN THE PRC**

Our manufacturing operations are entirely located in the PRC. Accordingly, our results of operations and financial position are subject to a significant degree to economic, political and legal developments in the PRC, including the following risks:

#### **Changes in the PRC's political, economic and social conditions, laws, regulations and policies may have an adverse effect on us.**

The economy of the PRC differs from the economies of most developed countries in many respects, including:

- structure;
- level of government involvement;
- level of development;
- growth rate;
- control of foreign exchange; and
- allocation of resources.

The PRC economy has been transitioning from a planned economy to a more market-oriented economy. For the past two decades, the PRC government has implemented economic reform measures emphasizing utilization of market forces in the development of the PRC economy. In addition, the PRC government continues to play a significant role in regulating industries by imposing industrial policies. Despite the implementation of such reforms, we cannot predict whether changes in the PRC's political, economic and social conditions, laws, regulations and policies will have any adverse effect on our current or future business, results of operations or financial condition.

#### **The PRC's legal system embodies uncertainties that could adversely affect our business and results of operations.**

Our manufacturing operations are located in China and almost all of our employees are PRC citizens. Our operations are therefore generally affected by and subject to the PRC legal system and PRC laws and regulations. Since 1979, many new laws and regulations covering general economic matters have been promulgated in China. Despite this activity to develop the legal system, China's system of laws is not yet complete. Even where adequate law exists in China, the enforcement of existing laws or contracts based on existing law may be uncertain or sporadic, and it may be difficult to obtain swift and equitable enforcement or to obtain enforcement of a judgment by a court of another jurisdiction. The PRC legal system is based on written statutes and their interpretation, and prior court

---

## RISK FACTORS

---

decisions may be cited for reference but have limited weight as precedents. The relative inexperience of China's judiciary in many cases creates additional uncertainty as to the outcome of any litigation. In addition, interpretation of statutes and regulations may be subject to government policies reflecting domestic political changes.

**A newly enacted PRC tax law could affect tax exemptions on dividends received by us and our shareholders and increase our enterprise income tax rate.**

We are incorporated under the laws of the Cayman Islands. As foreign legal persons, dividends derived from our business operations in the PRC are currently not subject to income tax under PRC law. However, we cannot assure you that such dividends will continue to be exempt from PRC income tax. A new law, the PRC Enterprise Income Tax Law, and its implementation rules, were enacted on March 16, 2007 and December 6, 2007, respectively, and became effective on January 1, 2008. Under the new laws, if we are deemed to be a non-PRC tax resident enterprise without an office or premises in the PRC, a withholding tax at the rate of 10% will be applicable to any dividends paid to us, unless we are entitled to reduction or elimination of such tax, including by tax treaties between the PRC and the Cayman Islands, as applicable. As of the Latest Practicable Date, the Cayman Islands do not have such tax treaties with the PRC. It is also unclear as to how such tax reduction and elimination, if any, would be implemented otherwise and whether dividends derived before year 2007, which have not been repatriated, will be also subject to 10% withholding tax.

In addition, the new laws provide that, if an enterprise incorporated outside the PRC has its "de facto management organization" located within the PRC, such enterprise may be recognized as a PRC tax resident enterprise and thus may be subject to enterprise income tax at the rate of 25% on their worldwide income. Substantially all members of our management are located in the PRC as of the effective date of the PRC Enterprise Income Tax Law. As such, we may be deemed a PRC tax resident enterprise and therefore subject to an enterprise income tax rate of 25% on our worldwide income (including dividend income received from our subsidiaries) which excluded the dividends received directly from another PRC tax resident. As a result of the changes described above, our historical operating results may not be indicative of our operating results for future periods and the value of our Shares may be adversely affected.

**Gain on the sales of our Shares and dividends on our Shares may be subject to PRC income taxes.**

Under the New PRC Enterprise Income Tax Law and its implementation rules, we may in the future be recognized as a PRC tax resident enterprise by the PRC taxation authorities, and capital gains realized by foreign shareholders from sales our Shares and dividends on our Shares payable to foreign shareholders may be regarded as income from "sources within the PRC" and therefore become subject to a withholding tax of 10% for our non-PRC enterprise shareholders or potentially 20% for non-PRC individual shareholders, unless foreign shareholders are entitled to reduction or elimination of such taxes by certain tax treaties. If we are required under the PRC income tax laws to withhold PRC income tax on capital gains on sales of our Shares and/or dividends on our Shares payable to foreign shareholders, the value of our foreign shareholders' investments in our Shares may be materially and adversely affected.

**Fluctuations in the exchange rates of the RMB may adversely affect your investment and could materially affect our financial condition and results of operations.**

The exchange rates between the RMB and the Hong Kong dollar, the U.S. dollar and other foreign currencies is affected by, among other things, changes in the PRC's political and economic conditions. In 2005, the PRC government changed its policy of pegging the value of the RMB to the U.S. dollar. Under the new policy, the RMB is pegged against a basket of currencies, determined by the People's Bank of China, against which it can rise or fall by as much as 0.5% each day.

---

## RISK FACTORS

---

There remains significant international pressure on the PRC government to adopt a more flexible policy, which could result in a further appreciation of the RMB against the U.S. dollar, the Hong Kong dollar or other foreign currency. As we rely on dividends paid to us by our operating subsidiaries, any significant revaluation of the RMB may have a material adverse effect on the value of dividends payable in foreign currency terms, to the extent that we need to convert the proceeds from the Global Offering and future financing into the RMB for our operations, appreciation of the RMB against the relevant foreign currencies would have an adverse effect on the RMB amount we receive from the conversion.

Moreover, following the completion of the Global Offering, we expect a significant portion of our cash and cash equivalents to be denominated in foreign currencies. As our functional currency is RMB, such foreign currency-denominated cash and cash equivalents are exposed to fluctuations in the value of the RMB against the currencies in which these cash and cash equivalents are denominated. Any significant appreciation of the RMB against these foreign currencies may result in significant exchange losses.

Furthermore, any appreciation of RMB increases our cost of production, and any devaluation of RMB may adversely affect the value of our net asset in foreign currency terms. As most of our growth is from exports, any appreciation of RMB could give rise of uncertainties in our financial condition and results of operations.

**It may be difficult to effect service of process upon us or our Directors who live in the PRC or to enforce against us or them in the PRC judgments obtained from non-PRC courts.**

Our Company is incorporated in the Cayman Islands. The majority of our Directors are residents of the PRC. Our Company is a holding company, a substantial proportion of the assets of our operating subsidiary and its directors are located within the PRC. Therefore, it may not be possible for investors to effect service of process upon us or those persons inside the PRC or to enforce against us or them in the PRC any judgments obtained from non-PRC courts.

The PRC does not have treaties providing for the reciprocal enforcement of judgments of courts with Japan, the United Kingdom, the United States or most other Western countries. In addition, Hong Kong has no arrangement with the United States for reciprocal enforcement of judgment. Accordingly, it may be difficult to secure recognition and enforcement in the PRC for court judgments obtained in other jurisdictions and to access our assets in China in order to enforce judgment awards entered against us outside of China. Therefore, it may be difficult for you to enforce against us, or our directors in the PRC, any judgments obtained from non-PRC courts.

**An outbreak of Severe Acute Respiratory Syndrome (SARS), Avian Flu (H5N1), Influenza A (H1N1) or any other similar epidemic may, directly or indirectly, adversely affect our operating results and the price of our Shares.**

Recently, certain Asian countries, including China, have encountered incidents of SARS, Avian Flu or Influenza A. If any of our employees is identified as a possible source of spreading SARS, Avian Flu, Influenza A or any other similar epidemic, we may be required to quarantine the employees that have been suspected of becoming infected, as well as others that have come into contact with those employees. We may also be required to disinfect our affected premises, which could cause a temporary suspension of our manufacturing capacity, thus adversely affecting our operations. Even if we are not directly affected by the epidemic, an outbreak of SARS, Avian Flu, Influenza A or other similar epidemic, whether inside or outside China, could restrict the level of economic activity generally, which could in turn adversely affect our operating results and our share price.

---

## RISK FACTORS

---

**Our corporate structure may restrict our ability to receive dividends from, and transfer funds to, our PRC operating subsidiary, which could restrict our ability to act in response to changing market conditions in a timely manner.**

Our Company is a Cayman Islands holding company and substantially all of our operations are conducted through our PRC operating subsidiary, MOBI Shenzhen. The ability of MOBI Shenzhen to make dividend and other payments to us may be restricted by factors that include changes in applicable foreign exchange and other laws and regulations. In particular, under PRC law, MOBI Shenzhen may only pay dividends after 10% of its net profit has been set aside as reserve funds, unless such reserves have reached at least 50% of its registered capital. In addition, the profit available for distribution from MOBI Shenzhen is determined in accordance with generally accepted accounting principles in China. This calculation may differ from one performed in accordance with HKFRSs. As a result, we may not have sufficient distributions from MOBI Shenzhen to enable necessary profit distributions to us or any distributions to our shareholders in the future, which calculation would be based upon our financial statements prepared under HKFRSs.

Distributions by MOBI Shenzhen to us other than as dividends may be subject to governmental approval and taxation. Any transfer of funds from our Company to MOBI Shenzhen, either as a shareholder loan or as an increase in registered capital, is subject to registration or approval of PRC governmental authorities, including the relevant administration of foreign exchange and/or the relevant examining and approval authority. These limitations on the free flow of funds between us and our PRC subsidiaries could restrict our ability to act in response to changing market conditions in a timely manner.

### **RISKS RELATED TO THE GLOBAL OFFERING**

**Purchasers of our Offer Shares will experience substantial and immediate dilution and may experience further dilution if we issue additional Shares in the future.**

The Offer Price of our Offer Shares is higher than the net tangible asset value per Share immediately prior to the Global Offering. Therefore, purchasers of our Offer Shares in the Global Offering will experience an immediate dilution in unaudited pro forma adjusted net tangible asset value to HK\$1.47 per Share, based on the maximum Offer Price of HK\$3.50 per Offer Share.

In order to expand our business, we may consider offering and issuing additional Shares in the future. We may also issue additional Shares pursuant to our Share Option Scheme and or a result of the exercise of Pre-IPO Options. Purchasers of our Offer Shares may experience dilution in the net tangible assets book value per Share of their Shares if we issue additional Shares in the future at a price which is lower than the net tangible assets book value per Share.

**Dividends declared in the past may not be indicative of our dividend policy in the future.**

Our Company declared dividends in the amount of RMB7,965,000, nil, RMB15,000,000 and RMB15,000,000 for the years ended December 31, 2006, 2007, 2008 and the eight months ended August 31, 2009, respectively. The amounts of distributions that our Company has declared and made in the past are not indicative of the dividends that we may pay in the future. A declaration of dividends proposed by our board and the amount of any dividends will depend on various factors, including, without limitation, our results of operations, financial condition, future prospects and other factors which our board may determine are important. For further details of our dividend policy, see “Financial Information — Dividend Policy.” We cannot guarantee if and when we will pay dividends in the future.

---

## RISK FACTORS

---

**Future sales by our Directors, officers and our current shareholders of a substantial number of our Shares in the public market could materially and adversely affect the prevailing market price of our Shares.**

Future sales of a substantial number of our Shares by our Directors, officers, or shareholders, or the possibility of such sales, could negatively affect the market price in Hong Kong of our Shares and our ability to raise equity capital in the future at a time and price that we deem appropriate. All of our shareholders as of the Latest Practicable Date have given undertakings on the holding of their Shares. Please refer to the subsection headed “Undertakings” in the section headed “Underwriting” to this prospectus for further details. While we are not aware of any intentions of any of our shareholders to dispose of significant amounts of Shares, we are not in a position to give any assurance that our shareholders will not dispose of any Shares in the future or those shareholders who have given undertakings on their Shares will not dispose of their Shares upon expiry of the relevant lock-up periods.

**The interests of our substantial shareholders may differ from your interests and their votes may disadvantage our minority shareholders.**

So far as the Directors are aware, immediately following completion of the Global Offering, the Capitalization Issue and conversion of the Series A Preferred Shares into Shares (without taking into account Shares that may be issued and allotted pursuant to the exercise of the Over-allotment Option or options granted under the Share Option Scheme or Shares that may be taken by a person under the Global Offering which would affect SFO disclosure purposes), each of the following current substantial shareholders will continue to hold a significant equity shareholding in our Company:

- Fangyi Holdings with 29.86%;
- SB Asia with 21.79%; and
- Shao Zhiguo with 5.91%.

The interests of any of these substantial shareholders may differ from your interests. We offer no assurance that any of these substantial shareholders will vote in a way that benefits you. If circumstances arise in which the interest of any of these substantial shareholders is in conflict with other shareholders’ interests, minority shareholders could be disadvantaged.

**We cannot guarantee the accuracy of certain facts and statistics with respect to the PRC, the PRC economy and the wireless communication industry contained in this prospectus.**

Certain facts and statistics contained in this prospectus relating to the PRC, the PRC economy and the PRC telecommunications industry have been derived from, among other sources, official PRC government publications generally believed to be reliable. However, we cannot guarantee the quality or reliability of such official government publications. They have not been prepared by us, the Global Coordinator, the Joint Sponsors or the Underwriters or any of our or their respective affiliates or advisors and, therefore, we make no representation as to the accuracy of the facts and statistics, or materials prepared based on the facts and statistics, contained in the official government publications, which may not be consistent with other information compiled within or outside the PRC. Due to possibly flawed or ineffective collection methods or discrepancies between published information and market practice and other difficulties, the facts and statistics contained in the official PRC government publications may be inaccurate or may not be comparable to the facts and statistics produced for other economies and should not be relied upon. Further, there is no assurance that they are stated or compiled on the same basis or with the same degree of accuracy as may be the case elsewhere.

In all cases, investors should give consideration as to how much weight or importance they should attach to or place on such facts or statistics derived from official government sources.

---

## RISK FACTORS

---

**Investors should read this entire prospectus carefully and we strongly caution you not to place any reliance on any information contained in press articles or other media regarding us and the Global Offering including, in particular, any financial projections, valuations or other forward looking statement.**

Prior to the publication of this prospectus, there has been press coverage regarding us and the Global Offering in Apple Daily on November 28, 2009, which contained certain information referring to us and the Global Offering that is not set out in this prospectus. We wish to emphasise to potential investors that neither we nor any of the Joint Sponsors, the Global Coordinator, the Underwriters, the Directors, officers, employees, advisers, agents or representatives of any of them, or any other parties (collectively, the “Professional Parties”) involved in the Global Offering has authorized the disclosure of any such information in the press, and neither the press reports, any future press reports nor any repetition, elaboration or derivative work was prepared by, sourced from, or authorized by us or any of the Professional Parties. Neither we nor any Professional Parties accept any responsibility for any such press or media coverage or the accuracy or completeness of any such information. We make no representation as to the appropriateness, accuracy, completeness or reliability of any such information or publication. To the extent that any such information is not contained in this prospectus or is inconsistent or conflicts with the information contained in this prospectus, we disclaim any responsibility, liability whatsoever in connection therewith or resulting therefrom. Accordingly, prospective investors should not rely on any such information in making your decision as to whether to subscribe the Offer Shares. You should rely only on the information contained in this prospectus and the Application Forms.

---

## WAIVERS FROM COMPLIANCE WITH THE COMPANIES ORDINANCE AND THE LISTING RULES

---

### MANAGEMENT PRESENCE IN HONG KONG

Pursuant to Rule 8.12 of the Listing Rules, we must have a sufficient management presence in Hong Kong. This normally means that at least two of our executive Directors must be ordinarily resident in Hong Kong. Given that the business and operation of our Group are primarily located, managed and conducted in the PRC and none of our executive Directors are ordinarily resident in Hong Kong, we do not, and for the foreseeable future will not, have two executive Directors residing in Hong Kong.

Accordingly, we have applied to the Stock Exchange for a waiver from compliance with the requirements under Rule 8.12 of the Listing Rules. In order to maintain effective communication with the Stock Exchange, we have put in place the following measures to ensure that regular communication is maintained between the Stock Exchange and us:

- (a) each Director/authorized representative of our Company will provide his office phone number, mobile phone number, residential phone number, fax number and e-mail address to the Stock Exchange. They will be contactable at their mobile phone numbers at all times;
- (b) each executive Director, non-executive Director and independent non-executive Director who are not ordinarily resident in Hong Kong holds valid travel documents to visit Hong Kong and will be able to meet with the Stock Exchange to discuss any matter in relation to our Company within a reasonable time frame, when required;
- (c) Hu Xiang (executive Director and authorized representative of our Company) and Wang Guoying (executive Director) are normally resident in Shenzhen, the PRC. They have confirmed that they will be able to meet with the Stock Exchange on short notice;
- (d) the two authorized representatives, Hu Xiang (executive Director, the chairman of the board of Directors and the chief executive officer of our Company) and Lee Wai Kuen (our deputy financial officer and company secretary), will act as our principal channels of communication with the Stock Exchange;
- (e) the two authorized representatives will be readily contactable by phone, facsimile and e-mail to promptly address inquires from the Stock Exchange;
- (f) the two authorized representatives will have means to contact all members of the Board (including the independent non-executive Directors) promptly at all times as and when the Stock Exchange wishes to contact them;
- (g) pursuant to Rule 3A.19 of the Listing Rules, our Company has retained First Shanghai Capital as its compliance adviser for the period commencing on the Listing Date and ending on the date on which our Company publishes its annual report in respect of its first full financial year commencing after the Listing Date to provide us with advice on our obligations in compliance with the Listing Rules, the Takeovers Code and the Code on Share Repurchases, including the publication of regulatory announcements, circulars or financial reports and the entry into notifiable or connected transactions. Such compliance adviser will act as the additional channel of communication with the Stock Exchange for the aforesaid period. Such compliance adviser will (i) provide the office address, the names, home and office phone numbers and fax numbers, e-mail addresses of two of its officers to the Stock Exchange and (ii) maintain all the office phone numbers, mobile phone numbers, fax numbers and e-mail addresses of the persons named in paragraph (a) above; and
- (h) in the event that an executive Director/authorized representative of our Company expects to travel and be out of office, he will have to provide the phone number of the place of his accommodation to the other authorized representative and the respective alternates.

---

## WAIVERS FROM COMPLIANCE WITH THE COMPANIES ORDINANCE AND THE LISTING RULES

---

### PRE-IPO OPTIONS

Under Rule 17.02(1)(b) of the Listing Rules, paragraph 27 of Appendix 1A and paragraph 10 of Part I of the Third Schedule to the Companies Ordinance, this prospectus is required to include details of the number, description and amount of any of our Shares which a person has, or is entitled to be given, an option to subscribe for, together with certain particulars of each option, namely the period during which it is exercisable, the price to be paid for Shares subscribed for under it, the consideration (if any) given or to be given for it or for the right to it and the names and addresses of the persons to whom it was given. We have granted options to 115 persons to subscribe for 25,557,500 Shares (post-Capitalization Issue) on the terms set out in the section entitled “5. Pre-IPO Options” in Appendix VI to this prospectus. Except for those grantees who are Directors, ex-director and senior management of the Group as disclosed in the section headed “5. Pre IPO Options” in Appendix VI to this prospectus, no grantees under the Pre-IPO Stock Incentive Plans are connected persons (as defined under the Listing Rules) or senior management of the Group.

Under the Pre-IPO Stock Incentive Plans, eligible persons include consultants or advisors who render or have rendered bona fide services to the Company (other than services in connection with the offering or sale of securities of the Company in a capital raising transaction or as a market maker or promoter of the Company’s securities). Three consultants were eligible persons under the 2003 Stock Incentive Plan, namely Mr. Lai Yongxiang, Tech Power Enterprises Limited and Ms. Ju Xinxia. Mr. Lai Yongxiang provided advisory services to the Group with respect to the direction of development in the PRC telecommunication industry and the use of applicable technology. Mr. Lai is one of the Beneficial Owners and he held 41,720,000 Shares in trust for the benefit of the Beneficial Owners from September 29, 2006 to May 30, 2007. Tech Power Enterprises Limited provided advisory services on corporate management to the Group and it is independent from the Company. Ms. Ju Xinxia provided advisory services as a company secretary to the Group. She is a member of the 39 Employee Shareholders and the company secretary of MOBI Shenzhen.

We have applied for (i) a waiver from the Stock Exchange from strict compliance with the disclosure requirements under Rule 17.02(1)(b) and paragraph 27 of Appendix 1A to the Listing Rules; and (ii) an exemption from the SFC from strict compliance with the disclosure requirements of paragraph 10 of Part I of the Third Schedule to the Companies Ordinance on the ground that full compliance with these requirements in respect of those participants of the Pre-IPO Stock Incentive Plans who are full-time or former employees of our Group and who are neither Directors, ex-director, senior management of our Group, consultants of our Company nor employees of our Group with a right to subscribe for more than 500,000 Shares (post-Capitalization Issue) (such participants to be collectively referred to as the “Grantees”) would be unduly burdensome for us due to the following reasons:

- (a) as the options granted under the Pre-IPO Stock Incentive Plans are considered as part of each Grantee’s remuneration package, individual information on such options is highly sensitive and confidential among the Grantees;
- (b) given the 94 Grantees involved, strict compliance with the applicable disclosure requirements under the Companies Ordinance on an individual basis in the prospectus will be costly and unduly burdensome on our Company in light of a significant increase in cost and timing for information compilation, prospectus preparation and printing;
- (c) the grant and exercise in full of the options granted under the Pre-IPO Stock Incentive Plans will not cause any material adverse change in the financial position of our Company;

---

## WAIVERS FROM COMPLIANCE WITH THE COMPANIES ORDINANCE AND THE LISTING RULES

---

- (d) the lack of full compliance of the applicable disclosure requirements under the Listing Rules and the Companies Ordinance will not hinder our Company in providing an informed assessment of our Company's activities, assets and liabilities, financial position, management and prospects to its potential investors; and
- (e) the disclosure of a summary of information relating to the options granted under the Pre-IPO Stock Incentive Plans, as described in the section headed "5. Pre-IPO Options" in Appendix VI to this prospectus should provide potential investors with sufficient information to make a relevant assessment of our Company in their investment decision-making process.

The Stock Exchange has granted the waiver to us on the following conditions:

- (a) on individual basis, full details of all the options granted by our Company under the Pre-IPO Stock Incentive Plans to the Directors, the ex-director and the five consultants of our Company, the senior management and any other employees of our Group with a right to subscribe for more than 500,000 Shares (post-Capitalization Issue), including all the particulars required under Rule 17.02(1)(b) of the Listing Rules, paragraph 27 of Appendix 1A to the Listing Rules and paragraph 10 of Part I of the Third Schedule to the Companies Ordinance, are disclosed in this prospectus;
- (b) in respect of the options granted by our Company to the grantees other than those referred to in sub-paragraph (a), the following details are fully disclosed in this prospectus:
  - (i) the aggregate number of grantees;
  - (ii) the aggregate number of Shares subject to such options;
  - (iii) the consideration paid for the grant of such options; and
  - (iv) the exercise period and the exercise price for such options;
- (c) the dilution effect and impact on earnings per Share upon full exercise of the options granted under the Pre-IPO Stock Incentive Plans are disclosed in this prospectus;
- (d) the aggregate number of Shares subject to the outstanding options granted by our Company under the Pre-IPO Stock Incentive Plans and the percentage of our Company's issued share capital of which such number represents are disclosed in this prospectus;
- (e) a summary of the Pre-IPO Stock Incentive Plans is disclosed in this prospectus; and
- (f) the list of all the grantees who have been conditionally granted options to subscribe for Shares under the Pre-IPO Stock Incentive Plans, containing all details as required under Rule 17.02 (1)(b), paragraph 27 of Appendix 1A to the Listing Rules and paragraph 10 of Part I of the Third Schedule to the Companies Ordinance, will be made available for public inspection.

The SFC has granted the exemption on the following conditions:

- (a) on individual basis, full details of all the options granted by our Company under the Pre-IPO Stock Incentive Plans to the Directors, the ex-director and the five consultants of our Company, the senior management and any other employees of our Group with a right to subscribe for more than 500,000 Shares (post-Capitalization Issue), including all the particulars required under paragraph 10 of Part I of the Third Schedule to the Companies Ordinance, are disclosed in this prospectus;

---

**WAIVERS FROM COMPLIANCE WITH  
THE COMPANIES ORDINANCE AND THE LISTING RULES**

---

- (b) in respect of the options granted by our Company to the grantees other than those referred to in sub-paragraph (a), the following details are fully disclosed in this prospectus:
  - (i) the aggregate number of grantees;
  - (ii) the aggregate number of Shares subject to such options;
  - (iii) the consideration paid for the grant of such options;
  - (iv) the exercise period and the exercise price for such options; and
- (c) the list of all the grantees who have been conditionally granted options to subscribe for Shares under the Pre-IPO Stock Incentive Plans, containing all details as required under paragraph 10 of Part I of the Third Schedule to the Companies Ordinance will be made available for public inspection.

Further details of the Pre-IPO Stock Incentive Plans and the waiver are set out in the sections headed “5. Pre IPO Options” and “7. Waivers from compliance with the Companies Ordinance and the Listing Rules” in Appendix VI to this prospectus respectively.

---

## **INFORMATION ABOUT THE PROSPECTUS AND THE GLOBAL OFFERING**

---

### **DIRECTORS' RESPONSIBILITY FOR THE CONTENTS OF THIS PROSPECTUS**

This prospectus includes particulars given in compliance with the Companies Ordinance, the Securities and Futures (Stock Market Listing) Rules and the Listing Rules for the purposes of giving information to the public with regard to our Group. Our Directors collectively and individually accept full responsibility for the accuracy of the information contained in this prospectus and confirm, having made all reasonable enquiries, that to the best of their knowledge and belief the information contained in this prospectus is accurate and complete in all material aspects and not misleading, there are no other facts the omission of which would make any statement in this prospectus misleading, and all opinions expressed in this prospectus have been arrived at after due and careful consideration and are formed on bases and assumptions that are fair and reasonable.

### **UNDERWRITING**

This prospectus is published solely in connection with the Hong Kong Public Offering. For applicants under the Hong Kong Public Offering, this prospectus and the Application Forms set out the terms and conditions of the Hong Kong Public Offering.

The Listing is jointly sponsored by Piper Jaffray Asia and First Shanghai Capital. The Hong Kong Public Offering is fully underwritten by the Hong Kong Underwriters under the terms of the Hong Kong Underwriting Agreement, subject to the agreement on the Offer Price between the Global Coordinator (on behalf of the Hong Kong Underwriters) and our Company on the Price Determination Date. The Global Offering is managed by Piper Jaffray Asia as the sole Global Coordinator. For further details of the Underwriters and the underwriting arrangements, please refer to the paragraph headed "Underwriting arrangements and expenses" under the section headed "Underwriting" in this prospectus.

### **RESTRICTIONS ON SALE OF SHARES**

Each person acquiring the Hong Kong Offer Shares under the Hong Kong Public Offering will be required to, or be deemed by his acquisition of Hong Kong Offer Shares, to confirm that he is aware of the restrictions on offers of the Offer Shares described in this prospectus.

The Hong Kong Offer Shares are offered for subscription solely on the basis of the information contained and representations made in this prospectus. No person is authorized in connection with the Hong Kong Public Offering to give any information, or to make any representation, not contained in this prospectus, and any information or representation not contained in this prospectus must not be relied upon as having been authorized by us, the Global Coordinator, the Joint Sponsors, the Underwriters or any of their respective directors or any other persons or parties involved in the Global Offering.

No action has been taken to permit any public offering of the Offer Shares or the distribution of this prospectus and/or the Application Forms in any jurisdiction other than Hong Kong. The distribution of this prospectus and the offering or sale of the Offer Shares in certain jurisdictions is restricted by law, in particular, but without limitation, the jurisdictions listed below. Accordingly, and without limitation to the jurisdictions listed below, this prospectus may not be used for the purpose of, and does not constitute, an offer or invitation, nor is it calculated to invite or solicit offers in any jurisdiction or in any circumstances in which such offer or invitation is not authorized or to any person to whom it is unlawful to make such an offer or invitation. Persons who possess this prospectus are deemed to have confirmed with our Company, the Global Coordinator, the Joint Sponsors and the Underwriters that such restrictions have been observed. Each person acquiring the Offer Shares will be required, and is deemed by his acquisition of the Offer Shares, to confirm that he is aware of the restrictions on offers of the Offer Shares described in this prospectus and that he is not acquiring, and has not been offered, any Offer Shares in circumstances that contravene any such restrictions.

---

## INFORMATION ABOUT THE PROSPECTUS AND THE GLOBAL OFFERING

---

The following information is provided for guidance only. Prospective investors of the Offer Shares should consult their financial advisers and take legal advice, as appropriate, to inform themselves of and to observe, all applicable laws and regulations of any relevant jurisdiction. Prospective investors of the Offer Shares should inform themselves as to the relevant legal requirements of applying any applicable exchange control regulations and applicable taxes in the countries of their respective citizenship, residence or domicile.

### **United Kingdom**

This prospectus does not constitute a prospectus for the purpose of the prospectus rules issued by the United Kingdom Financial Services Authority (“**FSA**”) pursuant to section 84 of the Financial Services and Markets Act 2000 (as amended) (“**FSMA**”) and has not been approved by or filed with the FSA. The Offer Shares may not be offered or sold and will not be offered or sold to the public in the United Kingdom (within the meaning of section 102B of the FSMA) save in circumstances where it is lawful to do so without an approved prospectus (within the meaning of section 85 of FSMA) being made available to the public before the offer is made. In addition, no person may communicate or cause to be communicated any invitation or inducement to engage in investment activity (within the meaning of section 21 of FSMA) received by it in connection with the issue or sale of any Offer Shares except in circumstances in which section 21(1) of FSMA does not apply to the Company. This prospectus is directed only at (i) persons outside the United Kingdom; or (ii) persons having professional experience in matters relating to investments who fall within the definition of “investment professionals” in article 19(5) of the Financial Services and Markets Act 2000 (Financial Promotions) order 2005 (as amended) (the “**FPO**”); or (iii) high net worth bodies corporate, unincorporated associations and partnerships and trustees of high value trusts as described in article 49 of the FPO or persons who fall within another exemption to the FPO. Any investment or investment activity to which this prospectus relates is only available to and will only be engaged in with such persons and any person who does not fall within (i) to (iii) above should not rely on or act upon this prospectus.

### **Singapore**

This prospectus has not been and will not be registered as a prospectus with the Monetary Authority of Singapore. Accordingly, this prospectus and any other document or material in connection with the offer or sale, or invitation for subscription or purchase, of the Offer Shares may not be circulated or distributed, nor may the Offer Shares be offered or sold, or be made the subject of an invitation for subscription or purchase, whether directly or indirectly nor may the Offer Shares, within a period of six months from the date of acquisition be subsequently resold, to the public or any member of the public in Singapore other than (i) to an institutional investor under Section 274 of the Securities and Futures Act, Chapter 289 of Singapore (the “**SFA**”), (ii) to a relevant person pursuant to Section 275(1) of the SFA, or any person pursuant to Section 275(1A) of the SFA, and in accordance with the conditions, specified in Section 275 of the SFA; or (iii) otherwise pursuant to, and in accordance with the conditions of, any other applicable provisions of the SFA.

### **People’s Republic of China**

This prospectus may not be circulated or distributed in the PRC and the Offer Shares may not be offered or sold directly or indirectly to any resident in the PRC, or offered or sold to any person for reoffering or re-sale directly or indirectly to any resident of the PRC except pursuant to applicable laws and regulations of the PRC.

---

## **INFORMATION ABOUT THE PROSPECTUS AND THE GLOBAL OFFERING**

---

### **APPLICATION FOR LISTING ON THE STOCK EXCHANGE**

Application has been made to the Listing Committee of the Stock Exchange for the listing of, and permission to deal in, the Shares in issue and to be issued as mentioned herein, including the Offer Shares, the Shares to be issued upon conversion of the Series A Preferred Shares, any Shares which may be issued pursuant to the Capitalization Issue, the exercise of the Over-allotment Option, the exercise of the Pre-IPO Options and the exercise of any options that may be granted under the Share Option Scheme.

Except as disclosed herein, no part of the share or loan capital of our Company is listed on or dealt in on any other stock exchange and no such listing or permission to list is being or is proposed to be sought in the near future.

Under section 44B(1) of the Companies Ordinance, any allotment made in respect of any application will be invalid if the listing of, and permission to deal in, the Offer Shares on the Stock Exchange is refused before the expiration of three weeks from the date of the closing of the application lists, or such longer period (not exceeding six weeks) as may, within the said three weeks, be notified to our Company by the Stock Exchange.

### **OUR SHARES WILL BE ELIGIBLE FOR ADMISSION INTO CCASS**

Subject to the granting of listing of, and permission to deal in, our Shares on the Stock Exchange and our Company's compliance with the stock admission requirements of HKSCC, the Shares will be accepted as eligible securities by HKSCC for deposit, clearance and settlement in CCASS with effect from the date of commencement of dealings in the Shares on the Stock Exchange or any other date as determined by HKSCC. Settlement of transactions between participants of the Stock Exchange is required to take place in CCASS on the second trading day after any trading day. All activities under CCASS are subject to the General Rules of CCASS and CCASS Operational Procedures in effect from time to time.

All necessary arrangements have been made for the Shares to be admitted into CCASS.

### **PROFESSIONAL TAX ADVICE RECOMMENDED**

You should consult your professional advisers if you are in any doubt as to the tax implications of subscription for, purchasing, holding, disposing of dealing in the Shares under the laws of the place at your operations, domicile, residence, citizenship or incorporation. We emphasize that none of our Company, the Global Coordinator, the Joint Sponsors, the Underwriters, any of their respective directors, agents or advisers or any other person involved in the Global Offering accepts responsibility for your tax effects or liabilities resulting from your subscription for, purchase, holding or disposal of or dealing in our Shares.

### **HONG KONG SHARE REGISTER AND STAMP DUTY**

All Shares issued pursuant to applications made in the Global Offering will be registered on our register of members to be maintained in Hong Kong.

Dealings in the Shares registered in our register in Hong Kong will be subject to Hong Kong stamp duty.

Unless determined otherwise by us, dividends payable in Hong Kong dollars in respect of Shares will be paid to the shareholders listed on our Hong Kong Share Register, by ordinary post, at the shareholders' risk, to the registered address of each shareholder.

---

## INFORMATION ABOUT THE PROSPECTUS AND THE GLOBAL OFFERING

---

### OVER-ALLOTMENT AND STABILIZATION

Stabilization is a practice used by underwriters in some markets to facilitate the distribution of securities. To stabilize, the underwriters may bid for, or purchase, the newly issued securities in the secondary market, during a specified period of time, to retard and, if possible, prevent a decline in the initial public offer prices of the securities. In Hong Kong and certain other jurisdictions, activity aimed at reducing the market price is prohibited, and the price at which stabilization is effected is not permitted to exceed the Offer Price.

In connection with the Global Offering, the Global Coordinator, as stabilizing manager, or, any person acting for it, may over-allocate or effect any other transactions with a view to stabilizing or maintaining the market price of the Shares at a level higher than that which might otherwise prevail in the open market for a limited period from Listing Date and ending on the 30th day after the last day for the lodging of applications under the Hong Kong Public Offering. Stabilizing action permitted in Hong Kong pursuant to the Securities and Futures (Price Stabilization) Rules includes (i) over-allocation for the purpose of preventing or minimizing any reduction in the market price, (ii) selling or agreeing to sell Shares so as to establish a short position in them for the purpose of preventing or minimizing any reduction in the market price, (iii) subscribing, purchasing, or agreeing to subscribe or purchase, shares pursuant to the Over-allotment Option in order to close out any position established under (i) or (ii) above, (iv) purchasing, or agreeing to purchase, Shares for the sole purpose of preventing or minimizing any reduction in the market price, (v) selling, or agreeing to sell, Shares to liquidate any long position held as a result of those purchases in (iv) and (vi) offering or attempting to do anything described in (ii), (iii), (iv) or (v). Any market purchases will be effected in compliance with all applicable laws and regulatory requirements. However there is no obligation on the Global Coordinator or any person acting for it to conduct any such stabilizing activity, which if commenced, will be done at the absolute discretion of the Global Coordinator or any person acting for it and may be discontinued at any time. Any such stabilizing activity is required to be brought to an end within 30 days of the last day for the lodging of applications under the Hong Kong Public Offering. The number of Shares that may be over-allocated will not exceed 26,327,000 Shares, which is approximately 15% of the number of Shares initially available under the Global Offering.

As a result of effecting transactions to stabilize or maintain the market price of the Shares, the Global Coordinator, or any person acting for it, may maintain a long position in the Shares. The size of the long position, and the period for which the Global Coordinator, or any person acting for it, will maintain the long position is at the discretion of the Global Coordinator and is uncertain. In the event that the Global Coordinator liquidates this long position by making sales in the open market, this may lead to a decline in the market price of the Shares.

Stabilizing action by the Global Coordinator, or any person acting for it, is not permitted to support the price of the Shares for longer than the stabilizing period, which begins on the day on which trading of the Shares commences on the Stock Exchange and ends on the 30th day after the last day for the lodging of applications under the Hong Kong Public Offering. The stabilizing period is expected to end on January 8, 2010. As a result, demand for the Shares, and its market price, may fall after the end of the stabilizing period. A public announcement will be made within seven days after the end of the stabilizing period in accordance with the Securities and Futures (Price Stabilizing) Rules.

Any stabilizing action taken by the Global Coordinator, or any person acting for it, may not necessarily result in the market price of the Shares staying at or above the Offer Price either during or after the stabilizing period. Bids for on-market purchases of the Shares by the Global Coordinator, or any person acting for it, may be made at a price at or below the Offer Price and therefore at or below the price paid for the Shares by subscribers or purchasers.

---

## **INFORMATION ABOUT THE PROSPECTUS AND THE GLOBAL OFFERING**

---

### **PROCEDURES FOR APPLICATION FOR HONG KONG OFFER SHARES**

The application procedure for the Hong Kong Offer Shares is set out in the section headed “How to apply for Hong Kong Offer Shares” in this prospectus and on the relevant Application Forms.

### **STRUCTURE OF THE GLOBAL OFFERING**

Details of the structure of the Global Offering, including its conditions, are set out in the section headed “Structure of the Global Offering” in this prospectus.

---

## DIRECTORS AND PARTIES INVOLVED IN THE GLOBAL OFFERING

---

### DIRECTORS

Name	Address	Nationality
<i>Executive Directors</i>		
Hu Xiang	20E, Block E, Yuanzhong Garden Futian District Shenzhen, Guangdong Province China	Chinese
Wang Guoying	301, Block 11, Pengxing Garden Guowei Road, Luohu District, Shenzhen Guangdong Province China	Chinese
<i>Non-Executive Directors</i>		
Qu Deqian	22F, Block 4, Haiyinchangcheng Nanshan District, Shenzhen, Guangdong Province, China	Chinese
Xing Qibin	306, Block 26, Haiyue Garden Shekou, Nanshan District Shenzhen, Guangdong Province China	Chinese
Yan Andrew Y.	House 9, 39 Deep Water Bay Road Hong Kong	Chinese
Yang Dong	Room 301, Block E, Building 6 Lizhuhuayuan, Nanshan District Shenzhen, Guangdong Province China	Chinese
<i>Independent Non-Executive Directors</i>		
Li Tianshu	57 Yiyuan, Quanfa Huayuan Beijing China	German
Zhang Han	25C, Block C, The Swan Castle Shahe, Nanshan District Shenzhen, Guangdong Province China	Chinese
Bao Fan	B216H, Global Trade Mansion No. 9A Guanghua Road Chaoyang District Beijing China	Chinese

---

## DIRECTORS AND PARTIES INVOLVED IN THE GLOBAL OFFERING

---

### PARTIES INVOLVED IN THE GLOBAL OFFERING

**Global Coordinator,  
Joint Bookrunner  
and Lead Manager**

Piper Jaffray Asia Securities Limited  
3901B, 39/F, Tower 1  
Lippo Centre  
89 Queensway  
Hong Kong

**Joint Bookrunner and  
Co-Lead Manager**

First Shanghai Securities Limited  
19/F, Wing On House  
71 Des Voeux Road Central  
Hong Kong

**Joint Sponsors**

Piper Jaffray Asia Limited  
3902B, 39/F, Tower 1  
Lippo Centre  
89 Queensway  
Hong Kong

First Shanghai Capital Limited  
19/F, Wing On House  
71 Des Voeux Road Central  
Hong Kong

**Hong Kong Underwriters**

Piper Jaffray Asia Securities Limited  
3901B, 39/F, Tower 1  
Lippo Centre  
89 Queensway  
Hong Kong

First Shanghai Securities Limited  
19/F, Wing On House  
71 Des Voeux Road Central  
Hong Kong

Taifook Securities Company Limited  
25/F, New World Tower  
16-18 Queen's Road Central  
Hong Kong

**International Underwriters**

Piper Jaffray Asia Securities Limited  
3901B, 39/F, Tower 1  
Lippo Centre  
89 Queensway  
Hong Kong

First Shanghai Securities Limited  
19/F, Wing On House  
71 Des Voeux Road Central  
Hong Kong

---

## DIRECTORS AND PARTIES INVOLVED IN THE GLOBAL OFFERING

---

China Merchants Securities (HK) Co., Limited  
48/F, One Exchange Square  
Central  
Hong Kong

CIMB Securities (HK) Limited  
25/F, Central Tower  
28 Queen's Road, Central  
Hong Kong

TSC Capital Limited  
Room 2803, 28/F.,  
Tower 1, Admiralty Centre  
18 Harcourt Road  
Hong Kong

**Legal advisers to the Joint Sponsors  
and Underwriters**

*as to Hong Kong law:*  
DLA Piper Hong Kong  
17/F, Edinburgh Tower  
The Landmark  
15 Queen's Road Central  
Hong Kong

*as to PRC law:*  
Commerce & Finance Law Offices  
6/F, NCI Tower, A12  
Jianguomenwai Avenue  
Chaoyang District  
Beijing 100022  
PRC

**Legal advisers to our Company**

*as to Hong Kong and United States law:*  
Jones Day  
29/F, Edinburgh Tower  
The Landmark  
15 Queen's Road Central  
Hong Kong

*as to PRC law:*  
Zhong Lun Law Firm  
10/F, Tower A  
Rongchao Centre  
6003 Yitian Road  
Futian District  
Shenzhen 518026  
China

*as to Cayman Islands law:*  
Maples and Calder  
53/F, The Center  
99 Queen's Road Central  
Hong Kong

---

## DIRECTORS AND PARTIES INVOLVED IN THE GLOBAL OFFERING

---

<b>Auditors</b>	Deloitte Touche Tohmatsu CPA Ltd. Shenzhen Branch Certified Public Accountants 13/F, China Resources Building 5001 Shennan Road East Shenzhen People's Republic of China
<b>Reporting accountants</b>	Deloitte Touche Tohmatsu Certified Public Accountants 35/F, One Pacific Place 88 Queensway Hong Kong
<b>Property valuer</b>	Savills Valuation and Professional Services Limited 23/F, Two Exchange Square Central Hong Kong
<b>Professional market research firm</b>	CCID Consulting Company Limited Room 210, 12 Huo Ju Jia Road Chang Ping District Beijing China
<b>Receiving banker</b>	Standard Chartered Bank (Hong Kong) Limited 15/F, Standard Chartered Tower 388 Kwun Tong Road Kwun Tong Hong Kong

---

## CORPORATE INFORMATION

---

<b>Registered office</b>	:	Maples Corporate Services Limited P.O. Box 309, Ugland House Grand Cayman KY1-1104, Cayman Islands
<b>Headquarter and principal place of business in the PRC</b>	:	7 Langshan First Road Science and Technology Park Nanshan District Shenzhen, Guangdong Province PRC
<b>Place of business in Hong Kong</b>	:	Room 1902 19/F, Massmutual Tower 38 Gloucester Road Wanchai Hong Kong
<b>Website of the Company</b>	:	<a href="http://www.mobi-antenna.com">www.mobi-antenna.com</a> <sup>(1)</sup>
<b>Company secretary</b>	:	Lee Wai Kuen <i>FCCA, CPA (Practising)</i>
<b>Authorized representatives</b>	:	Hu Xiang 20E, Block E, Yuanzhong Garden Futian District, Shenzhen Guangdong Province, China  Lee Wai Kuen Flat B, 20/F, Block 10 Hong Kong Gold Coast, Phase 2A 1 Castle Peak Road Tuen Mun, New Territories Hong Kong
<b>Audit committee</b>	:	Zhang Han ( <i>Chairman</i> ) Li Tianshu Bao Fan
<b>Remuneration committee</b>	:	Li Tianshu ( <i>Chairman</i> ) Zhang Han Bao Fan Qu Deqian Yan Andrew Y.
<b>Compliance adviser</b>	:	First Shanghai Capital Limited 19/F, Wing On House 71 Des Voeux Road, Central Hong Kong

---

*Note:*

(1) The information contained on the website of our Company does not form part of this prospectus.

---

## CORPORATE INFORMATION

---

**Hong Kong Share Registrar** : Computershare Hong Kong Investor Services Limited  
Shops 1712-1716  
17/F, Hopewell Centre  
183 Queen's Road East  
Wanchai, Hong Kong

**Principal banker** : China Merchants Bank  
1/F, Wenhua Building  
Shennan Road East  
Shenzhen 518002  
China

---

## INDUSTRY OVERVIEW

---

*The information and statistics set forth in this section have been extracted from a report issued by CCID dated October 2009, who has been commissioned by us, for a fee of RMB165,000, to prepare such a report on the communication network antenna and RF device market in China. Data compiled by CCID is based on published information and interviews with companies in the relevant industry, including us. Although reasonable care has been exercised by the Directors in extracting and repeating such information, the information may be inconsistent with other information compiled for our industry. All views expressed in this section are the independent views of CCID, which has not been prepared or independently verified by our Company, the Joint Sponsors, the Global Coordinator, the Underwriters or their respective directors or advisers. Our Company, the Joint Sponsors, the Global Coordinator, the Underwriters, their respective directors and advisers or any other parties involved in the Global Offering make no representation as to the accuracy or completeness of this information, which may not be consistent with information compiled from other sources, and accordingly such information contained in this section may not be accurate or complete and should not be unduly relied upon.*

### Introduction

We commissioned CCID, a market research company to conduct a detailed analysis of and report on the communication network antenna and RF device market in China. The methodology employed by CCID combines primary and secondary research to provide an analysis of these markets. Data collection was carried out by analysts with specific knowledge of the antenna system and RF device markets. Secondary sources such as company reports and trade data of industry groups and government statistics provided the historical context for the analysis of trends. In addition, CCID conducted interviews with the three wireless communication network operators in China, as well as other suppliers and manufacturers to support its forecast model. The interviews also served as a method of cross-checking and verifying data and assumptions. CCID's forecasts were developed by modeling key market drivers to determine the future development of the base station antenna system and RF device markets.

The information and statistics as set forth in this section have been extracted from the report issued by CCID.

### The Global Wireless Communication Industry

The global wireless communications industry has grown rapidly over the last few years, primarily driven by the continuous expansion of 2G networks, especially in emerging markets, the significant increase in the variety and quality of value-added mobile communication services, and the introduction of 3G networks and services. The number of mobile phone subscribers increased from approximately 2.11 billion as of December 31, 2006, to 4.01 billion as of December 31, 2008, representing a compounded annual growth rate, or CAGR, of 37.9% from 2006 to 2008, according to CCID. The table below sets forth the number of global mobile phone subscribers from 2006 to 2008.

	2006	2007	2008
Global mobile phone subscribers (in billion)	2.11	3.30	4.01
Year-on-year growth	9.3%	56.4%	21.5%

*Source: CCID*

The rapid growth in recent years has primarily been driven by growth in subscriber numbers in some of the largest and fast-growing markets such as China and India. China is currently the largest mobile communication market in the world by subscriber number. By the end of 2008, the number of mobile subscribers in China has surpassed 600 million. India only had less than 300 million of mobile subscribers by the end of July 2008, implying significant room for future growth.

---

## INDUSTRY OVERVIEW

---

In terms of protocol, GSM is the most commonly used in Asia, as well as some emerging markets in Latin America, Eastern Europe, the Middle East and Africa. As 2G networks continue to develop in these regions, both in terms of coverage and capacity, GSM networks and services are expected to continue to grow rapidly. On the other hand, CDMA is more commonly used in North America and certain Asian Pacific countries. By the end of March 2008, Verizon in the U.S., China Unicom and Reliance were the largest CDMA network operators in the world.

A more advanced generation of wireless voice and data transmission protocol is commonly referred to as the 3G standard. The specifications of the 3G standard is governed by the International Telecommunication Union, or ITU, which has approved six radio interface standards, three based on Code Division Multiple Access, or CDMA technology, commonly known as CDMA2000, W-CDMA and TD-SCDMA, as well as Universal Wireless Communications, or UWC, Digital Enhanced Cordless Telecommunications, or DECT, and Worldwide Interoperability for Microwave Access, or WiMax. Transmission protocols under the 3G standard have improved the rate of data transmissions beyond the data transmission rate of GSM and CDMA, the traditional 2G protocols, and offer better voice and data capabilities. GSM wireless communication network operators worldwide have been initiating their upgrade to 3G networks by deploying W-CDMA networks directly or indirectly through General Packet for Radio Service, or GPRS, upgrades and Enhanced Data rates for GSM Evolution, or EDGE, upgrades. Similarly, many operators of CDMA networks have been upgrading to 3G by deploying CDMA2000 networks.

Network operators around the world entered into a phase of rapid construction and upgrade to 3G since 2006. According to CCID, by the end of 2008 there were 264 W-CDMA networks, 269 CDMA1X networks and 159 CDMA1X-EVDO networks globally which led to the increase in demand for 3G network equipment. The W-CDMA networks are primarily spread across Western Europe. Japan is the first country in Asia to have established and commercialized 3G networks and services, using the CDMA2000 protocol. The growth in 3G services has been mainly attributable to (1) the systematic improvements in network, terminals, applications, tariffs and consumer awareness for 3G services; (2) the driving force created by profitable 3G operators in Japan and South Korea in 2008 motivating 3G operators in other countries to ramp-up their 3G services proactively. As the 3G market continues to develop, some of the existing and newly established 3G networks are already adopting more advanced technology such as High Speed Downlink Package Access, or HSDPA, Long-Term Evolution, or LTE, and Evolution-Data Optimized, or EV-DO technologies.

According to CCID, despite of the development of 3G networks and services, 2G networks and services are unlikely to be totally replaced by 3G in the near term, especially in countries like China, India, and other emerging markets in Asia and Africa where mobile penetration is still low. In these regions, 2G networks and services are likely to remain as the core platform of the development of wireless communication industry in the near term.

### **The Global Base Station Antenna and Base Station Subsystem Markets**

The wireless base station radio frequency, or RF, component market consists of products that improve coverage, capacity and data transmission rate in the wireless communications networks. These products, covering a variety of standards, protocols and frequency bands, together with the base station constitute a part of the base station system that, in turn, constitute a part of the wireless communication networks. In other words, in order to have wireless communication, a consumer's handheld device must be located in an area that is covered by the radio signal emitted from a wireless base station RF component.

---

## INDUSTRY OVERVIEW

---

The wireless base station RF component supply chain includes the base station antennas and base station RF subsystem components, which are also called RF devices. Base station antennas generally constitute approximately 5% - 6% of the cost of a base station, while base station antennas and RF devices, together, generally constitute approximately 11% - 12% of the cost of a base station. Because the wireless base station RF components are usually developed in conjunction with the design of the base stations, the base station manufacturers and wireless network solution providers have become very selective of their component suppliers over the years. Factors such as a supplier's ability to develop new products, provide technical services, communication skills and having a culture of providing cooperative services, are some of the selection criteria considered by base station manufacturers and network solution providers.

Traditionally, foreign network solution providers such as Ericsson, Nokia Siemens Networks, Motorola and Alcatel-Lucent have dominated the network solution provider market in China. In the past, these network solution providers also prefer suppliers that they have worked with such as Powerwave, Andrew, Kathrein-Werke and RFS, to be their principal suppliers. However, in recent years, China's domestic network solution providers have increased their market shares, while RF components suppliers in China have also become technologically sophisticated. As these sophisticated Chinese suppliers began to supply their products and services to foreign network solution providers and telecom operators, they ventured into the overseas markets on a large-scale. Moreover, with the construction and development of 3G networks in China, the size of the domestic market available to domestic suppliers is also expanding.

According to CCID, in line with the steady growth of mobile communication users and their level of usage and the rapid developments of 3G networks and services globally, the global base station antenna market has been growing in recent years, operators are expected to continue to increase the coverage and capacity of their existing and new networks, fuelling the future growth of the global base station antenna and RF device market. By the end of 2008, the size of the global base station antenna market has reached US\$4.6 billion. CCID is estimating the global base station antenna market to grow to US\$5.5 billion by the end of 2013. Likewise, by the end of 2008, the global RF device market has reached a size of US\$2.7 billion. CCID is estimating the global RF device market to grow to US\$3.4 billion by the end of 2013. According to CCID, the Company is the only Chinese company listed as one of the top ten worldwide suppliers of both base station antennas and RF devices based on 2008 industry data.

### **The Wireless Communication Industry in China**

According to CCID, China has grown to become the largest wireless communication market in the world by the number of mobile subscribers. By the end of 2008, the number of mobile subscribers in China has surpassed 600 million. CCID is projecting the number of mobile subscriber in China to reach 980 million by the end of 2013, representing an increase in penetration from 48.5% in 2008 to 72.7% in 2013.

In 2008, China completed the reorganization of its telecommunications industry, pursuant to which the number of mobile communication licenses increased from two to three, namely China Mobile, China Unicom and China Telecom. Some of the key components of such reorganization include China Telecom acquiring the CDMA network from China Unicom, and the merger of China Unicom with China Netcom. In January 2009, China announced the grant of three 3G operator licenses for TD-SCDMA, W-CDMA and CDMA2000 networks to China Mobile, China Unicom and China Telecom, respectively. Prior to the official grant of 3G licenses, China Mobile has already built and soft launched a small number of small scale regional networks using the TD-SCDMA technology, which is a protocol developed by the PRC government together with members of the TD-SCDMA Industry Association in China.

---

## INDUSTRY OVERVIEW

---

After the official grant of 3G licenses in China, the relevant operators have immediately and substantially increased their capital expenditure in rolling-out their 3G networks. According to CCID, sales volume of base stations in China in the first half of 2009 increased by close to 200% as compared to the same period in 2008, both in terms of volume and sales amount. According to CCID, there were approximately 2.5 million of 3G service subscribers in China by the end of June 2009, compared to approximately 0.8 million at the end of 2007. CCID is projecting the number of 3G subscribers in China to reach 161 million by the end of 2013, representing a penetration of 11.9%.

### The Base Station Antenna Market in China

According to CCID, with the growing demand for 3G base stations and consequently 3G base station antennas, the sales revenue of the base station antenna market in China for the first half of 2009 amounted to RMB3.79 billion, representing an increase of 82% as compared to the same period in 2008. In the next few years, the base station antenna market in China will follow the development trend of the base station market in China, CCID projects China's base station antenna sales revenue to increase from RMB2.08 billion in 2008 to RMB3.97 billion in 2010, and annual sales is expected to stabilize around this level for a few years from 2011 to 2013 before another phase of significant growth in China's antenna market begins when the next generation of mobile technology is commercialized.

In terms of application structure, the 2G base station application market still had an absolute leading advantage in 2008 according to CCID, the market shares of GSM and CDMA in the application market were 78.8% and 18.8%, respectively. As operators began to roll out the 3G network, CCID estimates that the percentage of 3G base station antennas sold to increase rapidly from 2009, and that by 2013, the percentage of 3G base station antennas sold in China will reach 90.6%.

The following table shows the percentage split of base station antenna sales in China in 2008 and CCID's projected percentage split from 2009 to 2013.

Year	2008	2009E	2010E	2011E	2012E	2013E
GSM	78.8%	30.6%	25.6%	13.0%	9.0%	7.0%
W-CDMA	—	18.2%	19.9%	24.6%	29.4%	32.4%
CDMA(2G)	18.8%	12.1%	13.9%	11.3%	4.9%	2.4%
CDMA(3G)	—	17.2%	18.4%	22.9%	26.8%	28.3%
TD-SCDMA	2.4%	21.9%	22.2%	28.2%	29.9%	29.9%
Total	<u>100%</u>	<u>100%</u>	<u>100%</u>	<u>100%</u>	<u>100%</u>	<u>100%</u>

Source: CCID

In addition, with the strengthening of the capability of China's domestic base station antenna enterprises and the increase of that product technological levels, domestic base station antenna enterprises have ventured into overseas markets on a large-scale, and exports have become an important source of sales revenue for them. Currently, the major export markets for China base station antennas are mainly emerging markets in Southeast Asia, Middle East, Latin America, Africa, India and Russia. At the same time, orders from mature markets such as North America and Europe also continue to increase. Part of these orders are exports resulting from the overseas engineering contracts undertaken by Huawei and ZTE, as well as direct sales to overseas manufacturers and operators of mobile communication equipment. Therefore, those Chinese base station antenna manufacturers who have international system equipment customers or whose products had large-scale applications overseas will enjoy certain advantages in developing international sales channels. According to CCID, total export revenue of base station antenna in 2008 amounted to approximately US\$130 million, representing an increase of 72.9% as compared to 2007.

---

## INDUSTRY OVERVIEW

---

The base station antenna market in China is highly concentrated. The PRC base station antenna market was dominated by international antenna producers in the past due to technological barrier and bundled sales of antennas with base stations that were principally sourced overseas. Since 2000, strengthened research and development capabilities have allowed PRC antenna providers to grow significantly. According to CCID, the market share of PRC antenna providers has increased from nil in 2000 to approximately 25% in 2002 and exceeded that of overseas antenna providers in 2004. In particular, PRC network operators began to source antenna products directly from antenna manufacturers after the network reorganization was completed, creating tremendous market opportunities for the domestic antenna industry. Domestically produced antenna currently have greater competitive advantage in the market, particularly in the 2G network, where technology of domestic antenna is more mature. At present, there are numerous domestic antenna enterprises and those enterprises with higher technology levels and larger sizes include Comba, MOBI, Xi'an Haitian, Guangdong Shenglu and Tongyu. With increasing investments in 3G base stations in China, and the driving force of improved technology and price advantages, the market shares of domestic antenna enterprises in the new generation of base station antenna market will continue to increase.

### **The Base Station RF Subsystem Market in China**

The base station RF subsystem products (also known as RF devices) include, but are not limited to, filters, duplexers, splitters, combiners, tower-mounted amplifiers, power amplifiers. Filters are used to select intended RF signals and isolate these signals from unwanted interference and noise. Duplexers are used to allow one antenna to both transmit and receive signals. Splitters allow the signals received from one antenna be distributed to different RF components. Combiners allow the combination of multiple signals from different RF components into one transmitting antenna. Tower mounted amplifiers improve network performance by performing the filtering and amplifying function as physically close as possible to the actual receiving antenna, thus eliminating additional signal loss and noise. Power amplifiers, which are located in base stations, are used in wireless networks to increase the radio signal power for transmission over long distances. All of these components are integrated into an end-to-end wireless communication network system and deployed in a wireless network at the base station or at a tower amplifier site.

For base station RF devices, their market development trend is consistent with that of the production volume of base stations in China. According to CCID, affected by the global economic conditions in 2008, the export volume of base stations declined by 17.7% in China. As a result, both production volume of base stations in China and the RF device market in China were affected to a greater extent, the sales of RF device market in China amounted to RMB2.14 billion in 2008, declined by 15.6% as compared to 2007. In 2009, the base station RF device market in China began to recover, recorded a growth of 35.5% in the first half of the year as compared to the same period year-on-year. CCID projects China's RF device sales revenue to increase from RMB2.14 billion in 2008 to RMB2.96 billion in 2010, and then further to RMB3.52 billion by 2013, as both the coverage and capacity of the networks in China continue to increase over the next few years.

In the application structure, the rapid growth of 3G applications is also a major development trend of the RF device market in China. It is anticipated by 2013, 3G applications in the RF device market of China will account for a market share of 72.5%, while W-CDMA, CDMA2000 and TD-SCDMA will account for 32.4%, 16.8% and 23.3%, respectively, of the total market.

---

## INDUSTRY OVERVIEW

---

The following table shows the percentage split of RF device sales in China in 2008 and CCID's projected percentage split from 2009 to 2013.

Year	2008	2009E	2010E	2011E	2012E	2013E
GSM	38.3%	28.2%	26.0%	23.7%	21.2%	19.6%
W-CDMA	26.2%	23.9%	26.0%	27.5%	30.6%	32.4%
CDMA(2G)	18.2%	12.1%	11.2%	9.8%	8.8%	8.0%
CDMA(3G)	15.4%	13.6%	14.5%	15.2%	15.9%	16.7%
TD-SCDMA	1.9%	22.2%	22.3%	23.8%	23.5%	23.3%
Total	<u>100%</u>	<u>100%</u>	<u>100%</u>	<u>100%</u>	<u>100%</u>	<u>100%</u>

Source: CCID

Considering the cost advantages, the RF device industry in China has been developing rapidly in recent years as international mobile communication equipment leaders have been shifting their procurement focus continuously to China. The rapid development of the global communication equipment market has driven the ever increasing market demand for RF devices. Suppliers of mobile communication RF subsystems and devices mainly supply their products to base station manufacturers and wireless RF equipment production enterprises (including the wireless network optimization industry). Judging from the existing conditions, exports of RF devices mainly exist in two forms, one type is by way of "indirect export" where the RF device is installed as part of a completed machine or solution before exporting; another type is "direct export" of RF devices. At present, indirect export of RF devices account for more than 80% market share. With the continuous expansion of the overseas business scale of domestic equipment production enterprises such as ZTE and Huawei, such "indirect exports" is expected to grow rapidly. On the other hand, in order to lower product costs, international equipment manufacturers procure RF device products directly through their Chinese subsidiaries, and then make allocations according to business needs on a global scale. Such procurement effort is increasing year by year in China. Overall, "indirect exports" is still the mainstream in the exports of RF devices and remains the dominant form of exports for base station RF devices in China.

At present, suppliers of base station RF devices mainly include European and American enterprises such as Powerwave and CommScope of the United States, Kathrein-Werke of Germany, RFS of France, and domestic manufacturers such as Fingu, MOBI and Grentech, etc. In recent years, frequent consolidations have been going on in the industry with increasing mergers and acquisitions and reorganizations among enterprises, and the RF supply chain in China has gained significant growth in technology capability. Meanwhile, as multinational base station system equipment companies increase their purchases in China, the Chinese RF device suppliers are beginning to supply to international base station system equipment makers and starting to export to emerging markets and countries such as India and South America. The competitiveness of domestic RF device manufacturers is expected to continue to strengthen in the future.

### Information about CCID

CCID Consulting Co., Ltd, or CCID, is a Chinese consulting firm listed in the Growth Enterprise Market of the Stock Exchange (GEM) of Hong Kong (stock code: 8235). It provides professional market research and management consultancy services. CCID prepares periodic research reports on many different industries including the telecommunication industry. CCID is independent of our Group and none of our Directors or its associates has any interest in CCID.

---

## REGULATION

---

### INDUSTRY REGULATION IN CHINA

#### Relevant PRC Laws and Regulations in relation to the Industry

Based on the business scope the subsidiaries of our Company registered with the relevant government approval and registration authorities in the PRC, products manufactured by the subsidiaries of our Company are categorized as telecommunication equipment. This industry is regulated by the MII. Relevant important PRC laws and regulations of the industry include the Regulations of the People's Republic of China on the Administration of Radio Operations (《中華人民共和國無線電管理條例》) (“Regulations on Radio Administration”), Provisions on the Administration of Manufacturing of Radio Transmission Equipment (《生產無線電發射設備的管理規定》) (“Provisions on Radio Administration”), Regulations on Telecommunications of the People's Republic of China (《中華人民共和國電信條例》) (“Regulations on Telecommunications”) and Administrative Measures on the Network Access of Telecommunication Equipment (《電信設備進網管理辦法》) (“Network Access Administrative Measures”). These are briefly described below.

#### Regulations on Radio Administration

Pursuant to the Regulations on Radio Administration jointly promulgated by the State Council of the PRC (中華人民共和國國務院), or the State Council, and the Central Military Commission in September 1993, the State Radio Administration Commission (currently the Radio Administration Bureau (無線電管理局) under the MII) is responsible for the radio administration of non-military radio systems throughout the PRC. Where an enterprise manufactures radio transmission equipment, its working frequency, frequency band and relevant technical standards are required to comply with the State Council's provisions on radio administration, and must be registered with the national radio administration organization or local radio authorities.

#### Provisions on Radio Administration

Pursuant to the Provisions on Radio Administration jointly issued by the State Radio Administration Commission and the State Technology Supervision Bureau (國家技術監督局) on October 7, 1997, a system for approving product models must be implemented with respect to the manufacturing of radio transmission equipment. The Office of the State Radio Administration Commission (國家無線電管理委員會辦公室) (“Office of Radio Commission”) is required to audit radio transmission equipment manufactured by an enterprise based on the transmission characteristics for a particular model, and issue a “Certificate of Approval of Model of Radio Transmission Equipment (無線電發射設備型號核准證) and model approval code upon satisfactory audit outcome. Equipment manufactured by an enterprise shall specify such model approval code on its label.

Pursuant to the Regulations on the Administration of Radio in Shenzhen Special Economic Zone as promulgated on January 21, 2009 by the Standing Committee of Shenzhen Municipal People's Congress and implemented with effect from May 1, 2009, the manufacturing of radio transmission equipment in Shenzhen is subject to approval by the Office of Radio Commission on the particular type of transmission, as well as its issuance of the Certificate of Approval of the Model of Radio Transmission Equipment and model approval code. A manufacturer is required to make an application to the Shenzhen Radio Office for such certificate. An application will be initially reviewed by the Shenzhen Radio Office and then reported to the State Radio Administration Commission for decision. Upon obtaining the Certificate of Approval of the Model of Radio Transmission Equipment, the approved model of radio transmission equipment will then be permitted for production.

---

## REGULATION

---

### **Regulations on Telecommunications**

Pursuant to the Regulations on Telecommunications promulgated by the State Council on September 25, 2000, the MII has implemented regulatory control over the nationwide telecommunication industry. Under the supervision of the MII, telecommunications regulatory authorities of provinces, autonomous regions and municipalities directly under the PRC central government have accordingly implemented regulatory control over our telecommunication industry.

The State Council has implemented a network access licensing system for telecommunication terminal equipment, radio communication equipment and interconnection equipment. Any telecommunication terminal equipment, radio communication equipment and interconnection equipment connecting to a public network must comply with the standards specified by the State Council and be issued a network access licence. A list of telecommunication equipment under the network access licensing system is compiled and issued by the MII together with the product quality supervisory division of the State Council. Such division of the State Council together with the responsible division of the MII is responsible for following-up on the product quality of those telecommunication equipment granted with network access licences, supervising their random inspections and announcing the results of their random inspections.

### **Network Access Administrative Measurements**

Pursuant to the Network Access Administrative Measurements promulgated by the MII on May 10, 2001, the State Council has implemented a telecommunication equipment network access licensing system for telecommunication terminal equipment, radio communication equipment and interconnection equipment connecting to public networks. Telecommunication equipment under the network access licensing system must be issued a network access licence by the MII. Telecommunication equipment without a network access license may not be connected to public telecommunication networks and the domestic sale of these equipment in the PRC is prohibited.

The list of telecommunication equipment under the network access licensing system is compiled and issued by the MII and the product quality supervisory division of the State Council in accordance with the network access licensing system. When applying for a telecommunication network access licence, manufacturers of telecommunication equipment (“manufacturing enterprises”) must comply with the laws, regulations and policy requirements of the PRC. Telecommunication equipment under application for network access licence must comply with the national standards, standards of the communication industry and the requirements of the MII. Telecommunication equipment manufacturing enterprises should have a comprehensive quality assurance system and provisions for after-sale services. When applying for telecommunication equipment network access licences, manufacturing enterprises must enclose an inspection report authorized by the product quality supervisory division of the State Council and issued by inspection authorities appointed by the MII, or a product quality certificate issued by certification authorities. When inspection authorities inspect telecommunication equipment under application for network access licences, the basis of inspection, the inspection procedures and the inspection reports to be issued shall comply with the provisions of the State Council or the MII. The Telecommunication Administration Bureau of the PRC is generally responsible for the administration of telecommunication equipment connecting to public networks and the supervision of inspections nationwide. Approval authorities appointed by the MII are responsible for handling applications for telecommunication equipment network access licences.

Within 60 days after receipt of an application for a telecommunication equipment network licence, the responsible division of the MII shall complete its review of the application and the telecommunication network access licence as well as the related label will be granted to applicants that have passed the review. The telecommunication equipment manufacturing enterprises must ensure the stability and reliability of the quality of telecommunication equipment granted with network access licences, and may not lower its product quality and performance.

---

## REGULATION

---

Telecommunication equipment manufacturing enterprises must attach network access licence labels to the telecommunication equipment produced by them and granted with network access licences. The network access licence labels are centrally printed and issued by the MII. Such network access licence labels represent a symbol for quality, and must not be attached to telecommunication equipment without network access licences or with invalid network access licences. The network access licences and network access licence labels should not be transferred, amended, forged or counterfeited. Manufacturing enterprises must clearly mark the network access licence code on the packages of the telecommunication equipment granted with network access licences, and specify such network access licence code in any published advertisement.

The MII regularly publishes lists of telecommunication equipment and manufacturing enterprises which have been granted network access licences. Manufacturing enterprises with network access licences must, as soon as practicable, register with, and operate subject to the supervision and administration of, the communication administration bureaus of provinces, autonomous regions and municipalities directly under the central government in which they are located. No one may re-inspect and issue certificates to those telecommunication equipment already granted with network access licences. Telecommunication business operators shall not use any telecommunication equipment under the network access licensing system which has not granted a network access licence.

### **Environmental Protection Law**

Pursuant to the Environmental Protection Law of the People's Republic of China (the "Environmental Protection Law") as promulgated and implemented by the Standing Committee of the Seventh National People's Congress on December 26, 1989, the environmental protection administration department under the State Council shall conduct unified supervision and management of the environmental protection work throughout the PRC.

Pursuant to the Environmental Protection Law, the environmental protection administration department under the State Council shall establish pollutant discharge standards in accordance with the national environmental quality standards as well as the national economic and technological conditions. The construction of projects that will cause environmental pollution shall comply with the State Council regulations with respect to environmental administration in construction projects, including, among others, the stipulations that the pollution prevention facilities in such construction project shall be designed, constructed and put into operation simultaneously to the main body of such project; that such construction project shall not be put into operation or use until the pollution prevention facilities have been inspected and examined by the environmental protection administration department which approved the environmental impact assessment report; and that pollution prevention facilities shall not be dismantled or abandoned without authorisation.

In addition, business entities or units which discharge pollutants shall file registrations pursuant to the relevant regulations. Such entities or units shall be liable for a fee for any discharge of pollutants in excess of the State Council or local pollutant discharge standards and shall be responsible for remedy.

### **Environmental Impact Assessment Law**

Pursuant to the Environmental Impact Assessment Law of the People's Republic of China (the "Environmental Assessment Law") as promulgated on October 28, 2002 and implemented by the Standing Committee of the Ninth National People's Congress on September 1, 2003, construction units of any projects having an impact on the environment shall analyse, forecast, and assess the environmental impact that may result from the implementation of the design and construction of such projects; propose actions and measures which can prevent or remedy adverse environmental impact; and implement methodologies and systems for follow-up tracking and monitoring.

---

## REGULATION

---

Construction units shall make arrangement for preparing environmental impact assessment reports or environmental impact assessment forms or fill in environmental impact registration forms. Where the environmental impact assessment documentation has not been examined by the approval authority as stipulated by law or has not been granted approval upon examination, the approval authority for such project shall not approve the construction and the construction unit shall also be prohibited from commencing any construction work. If there is any material change on the nature, scope, location, manufacturing techniques or pollution prevention or ecological conservation measures of a construction project after the approval of the environmental impact assessment documentation, the construction unit shall submit a new document for environmental impact assessment for the construction project for examination and approval.

### **Measures for the Control of Pollution from Electronic Information Products and corresponding standards**

On February 28, 2006, seven ministries and commissions of the PRC — the MII, the National Development and Reform Commission, Ministry of Commerce, the General Customs Administration, the SAIC, the General Administration of Quality Supervision, Inspection and Quarantine, and the State Environmental Protection Administration jointly promulgated the Measures for the Control of Pollution from Electronic Information Products (the “Control Measures”), which were implemented as of March 1, 2007. On November 6, 2006, the MII further promulgated three corresponding standards, namely the Testing Methods for Hazardous Substances in Electronic Information Products, the Requirements for Concentration Limits for Certain Hazardous Substances in Electronic Information Products, and the Marking for Control of Pollution Caused by Electronic Information Products. The various ministries and commissions will undertake joint monitoring and management within the scopes of their respective responsibilities with respect to the Control Measures and the corresponding standards.

The Control Measures are applicable to electronic information products manufactured and distributed in or imported to the PRC. Under the Control Measures, for any products which are expressly set forth in the Notes on Classification in the Catalog of Electronic Information Products, including mobile communication equipment, cellular mobile communication equipment, mobile communication base stations, contain toxic or hazardous materials or elements, or contain toxic or hazardous materials or elements in excess of national standards or industry standards, the Control Measures and the relevant corresponding measures shall be taken in the research and development, design, production, distribution and importation of such products. General electronic information products shall have certain information imprinted thereon in accordance with the requirements of the corresponding standards. Relevant information includes the names and the amounts of toxic and hazardous materials or elements contained, the environmental friendly use period, recycling use and the names of packaging materials. In addition, the State Council will promulgate the Key Administrative Catalog for the Control of Pollution Caused by Electronic Information Products (the “Key Administrative Catalog”). Electronic information products included in the Key Administrative Catalog shall comply with higher standards in pollution control requirements and shall also undertake the China compulsory certification (CCC). Currently, the State Council has not yet promulgated the Key Administrative Catalog.

The products shall be imprinted with the required information and data in accordance with the product marking requirements. It is not necessary for suppliers of components of an entire machine to imprint their products with the required information, but rather to supply all such information to the purchasers, who in turn shall make the product markings available on the ultimate products to be put into the market. The scope of marking information shall include all electronic information products purchased for manufacturing and assembling the ultimate products.

---

## REGULATION

---

### **Our Operations and Licences**

Our business scope, as registered with the relevant approval and registration authorities of the PRC government, includes the research and development, manufacture and trading of mobile communication network base station, antennas, radio frequency (RF) devices, RF modules, RF (sub) systems, RF cables, small integrated systems for communication, and after sales installation services.

Our Directors confirm that the products actually manufactured by us at present include mobile communication antennas, various kinds of RF devices and components, RF cables, various ancillary products for mobile base stations, but exclude base stations for mobile communication (including GSM, CDMA and PHS), and we currently do not engage in actual business of small integrated systems for communication. Pursuant to relevant laws and regulations in the PRC, and with confirmation from the relevant government authorities, no ratification and/or approval from the relevant government authorities is required for the production and sale of mobile communication antennas, various kinds of RF devices and components, RF cables, various ancillary products for mobile base stations. We may develop, manufacture and sell the foregoing products.

Our Directors confirm that we may sell products currently manufactured by us, and may choose to sell such products domestically or overseas at our discretion without any special approval from any regulatory authority of the PRC government. Pursuant to existing PRC laws and regulations, the quantity and price of the products manufactured and/or sold by us are not restricted by any mandatory program, guideline or rule. We may determine the quantity and price with reference to market demand or through negotiation with our customers. Our legal advisers as to PRC laws confirm that the production and sales of all our products comply with all relevant PRC laws and regulations on environmental protection and pollution control, and that our current operations or products are not subject to any special approval from any PRC authorities and that we have obtained all the necessary permits, licences and certificates for its operations throughout 2006, 2007, 2008 and the eight months ended August 31, 2009.

With respect to our overseas sales, our overseas customers, including our direct overseas customers, the factories or inventory hubs of global suppliers, or local distributors who would, in turn, resell our products to the local network operators, provide us with the specifications or requirements they required for their particular needs. While we have no direct knowledge of the exact location where some of our products may be installed, as our overseas customers must purchase for their own accounts or their affiliates' accounts, and the title of the products passes upon the delivery of our products to them or the payment of the purchase price for our products, depending on the purchase orders. Our end customers would be required to comply with the relevant laws and regulations of the location where they intend to install our products by providing us with the correct specifications ahead or upon placing their purchase orders. So long as we manufacture according to the specifications or requirements, the risk of any non-compliance with local laws and regulations rests with the local network operators.

Should there be any change to our business, products or to the PRC laws and regulations which render ratification and/or approval of the relevant regulatory authorities of the PRC government applicable to us, we will then seek to obtain relevant ratification and/or approval immediately. In particular, should we be involved in the manufacture, sales and marketing of base stations for mobile communication (including GSM, CDMA and PHS), the foregoing Regulations on Radio Administration, Provisions on Radio Administration, Regulations on Telecommunications and Network Access Administrative Measures will apply to us.

---

## HISTORY AND DEVELOPMENT

---

### OUR OPERATIONS

#### Our operation in Shenzhen

Our history began with the establishment of MOBI Shenzhen as a limited liability company under the laws of the PRC on August 12, 1999. MOBI Shenzhen was founded by Shenzhen Weixiantong, Wang Beirong, Hou Weigui, Wang Guoying, Shao Zhiguo and Hu Xiang (the “Initial Shareholders”). The Initial Shareholders were both the registered and beneficial shareholders of MOBI Shenzhen. Upon establishment, MOBI Shenzhen had a registered capital of RMB3,000,000, which was fully paid up. MOBI Shenzhen is our principal operating subsidiary.

#### Our operation in Jiangxi

We established MOBI Jian on May 23, 2006. MOBI Jian is our wholly-owned subsidiary which is engaged in the manufacture and sales of mobile communication network base station antennas and other antennas, RF devices and components and RF cables for PHS, GSM, CDMA, TDS-CDMA, WCDMA and CDMA2000 protocols.

#### Our operation in Xian

On April 29, 2008, MOBI Shenzhen established its wholly-owned subsidiary, MOBI Xian which is engaged in research, development and production of mobile communication network base station antennas, RF devices and components for GSM, CDMA, TDS-CDMA, WCDMA and CDMA2000 protocols.

### OUR CORPORATE HISTORY

Our Company was incorporated in the Cayman Islands as an exempted company with limited liability on December 16, 2002.

Prior to the Reorganization, we operated our business through our wholly-owned subsidiary, MOBI Shenzhen, which is engaged in the manufacture, sales and marketing of mobile communication network base station antennas and other antennas, RF devices and components for PHS, GSM, CDMA and other protocols.

The diagram below sets forth the Initial Shareholders’ equity interest in MOBI Shenzhen immediately prior to the Reorganization:

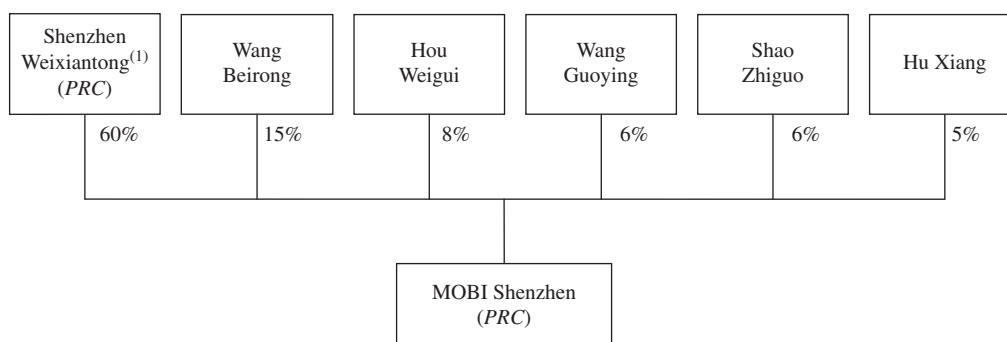

*Note:*

- (1) Through Shenzhen Weixiantong, the Beneficial Owners jointly invested in MOBI Shenzhen prior to the incorporation of our Company.

---

## HISTORY AND DEVELOPMENT

---

### Our Reorganization

We underwent the Reorganization as described below in preparation for the listing of our Shares on the Stock Exchange.

#### *Our incorporation and issuance of Shares*

On December 16, 2002, our Company was incorporated in the Cayman Islands as an exempted company with limited liability.

On December 19, 2002, the one subscriber Share was transferred from Mapcal Limited as an initial subscriber to Hu Xiang for nominal consideration. On the same day, in consideration of the commitment by the grantees to provide and procure services to our Company, our Company allotted and issued a total of 74,499,999 Shares to the following grantees:

Shareholder	Number of Shares
Qu Deqian	47,322,400
Wang Beirong	9,312,500
Hu Xiang	4,618,999
Wang Guoying	4,946,800
Shao Zhiguo	5,043,650
39 Employee Shareholders <sup>(1)</sup>	<u>3,255,650</u>
Total:	<u><u>74,499,999</u></u>

---

*Note:*

- (1) As of the Latest Practicable Date, the 39 Employee Shareholders do not have any relationship with us other than being our employees or consultants, and that the 39 Employee Shareholders are not related to other shareholders of our Company and are not related to one another.

#### *Qu Deqian as trustee*

Among the grantees, Qu Deqian held 41,720,000 Shares in trust for the benefit of Shenzhen Weixiantong and 5,602,400 Shares in trust for the benefit of Hou Weigui, pursuant to two declarations of trust dated December 19, 2002. Pursuant to a declaration of trust dated May 16, 2007, Shenzhen Weixiantong further confirmed and acknowledged an earlier oral arrangement with the Beneficial Owners made on December 19, 2002 that since December 19, 2002, the interest in those 41,720,000 Shares had, in turn, always been held in trust for the Beneficial Owners in the proportion set forth in column B of the chart below entitled “Summary on the Beneficial Owners”. In order to maintain the Beneficial Owners’ relative beneficial equity interests in the Shares, a separate trust arrangement was made for Qu Deqian to hold the 5,602,400 Shares in trust for the benefit of Hou Weigui.

## HISTORY AND DEVELOPMENT

### Summary on the Beneficial Owners

Beneficial Owner*	Column A	Column B	Column C	Column D	Column E
Principal business or occupation	Number of Shares held in trust as of December 19, 2002	Number of Shares held in trust as of April 20, 2007 in relation to the exercise of the Share Warrant	Number of Shares held in trust as of April 20, 2007 in relation to the exercise of the Share Warrant	Total number of Shares held in trust for the period from April 20, 2007 to May 30, 2007 and transferred to the Beneficial Owners on May 31, 2007	Shareholding Interest in Fangyi Holdings (%)
1. Hou Weigui <sup>(1)</sup>	ZTE chairman	7,509,600	37,548	7,547,148	18
2. Yin Yimin <sup>(1)</sup>	ZTE director and senior management	2,086,000	10,430	2,096,430	5
3. Zhu Jinwen <sup>(1)</sup>	Retiree <sup>(4)</sup>	2,086,000	10,430	2,096,430	5
4. Jiang Shumin <sup>(1)</sup>	Merchant	1,251,600	6,258	1,257,858	3
5. Shi Lirong <sup>(1)</sup>	ZTE director and senior management	1,251,600	6,258	1,257,858	3
6. Tang Xi <sup>(1)</sup>	Retiree <sup>(4)</sup>	1,251,600	6,258	1,257,858	3
7. Wang Honghai	Merchant	1,251,600	6,258	1,257,858	3
8. Yu Wancheng	Retiree <sup>(4)</sup>	1,251,600	6,258	1,257,858	3
9. Zhou Susu <sup>(1)(2)</sup>	ZTE employee	1,251,600	6,258	1,257,858	3
10. Zhu Weimin	Merchant	1,251,600	6,258	1,257,858	3
11. Wei Zaisheng <sup>(1)</sup>	ZTE senior management	1,251,600	6,258	1,257,858	3
12. Wei Xingmin <sup>(1)</sup>	Shenzhen Zhongxingxin director	1,251,600	6,258	1,257,858	3
13. He Shiyou	ZTE director and senior management	876,120	4,380.60	880,500.60	2.1
14. Hu Xiang <sup>(2)</sup>	Director and our senior management	876,120	4,380.60	880,500.60	2.1
15. Hong Bo	Merchant	834,400	4,172	838,572	2
16. Liang Huming <sup>(3)</sup>	ZTE employee	834,400	4,172	838,572	2
17. Qu Deqian	Shenzhen Weixiantong senior management and our Director	834,400	4,172	838,572	2
18. Zhang Yan <sup>(3)</sup>	ZTE employee	834,400	4,172	838,572	2
19. Han Wei	ZTE employee	834,400	4,172	838,572	2
20. Lai Yongxiang	ZTE employee and director of Fangyi Holdings	834,400	4,172	838,572	2
21. Song Zhongshen	Retiree <sup>(4)</sup>	834,400	4,172	838,572	2
22. Gao Xueping	ZTE employee	750,960	3,754.80	754,714.80	1.8
23. Bai Qi	Retiree <sup>(4)</sup>	625,800	3,129	628,929	1.5
24. Cui Yulong	ZTE employee	625,800	3,129	628,929	1.5
25. Li Li	Merchant	625,800	3,129	628,929	1.5
26. Wei Wangmin	Retiree	625,800	3,129	628,929	1.5

## HISTORY AND DEVELOPMENT

Beneficial Owner*	Column A Principal business or occupation	Column B Number of Shares held in trust as of December 19, 2002	Column C Number of Shares held in trust as of April 20, 2007 in relation to the exercise of the Share Warrant	Column D Total number of Shares held in trust for the period from April 20, 2007 to May 30, 2007 and transferred to the Beneficial Owners on May 31, 2007	Column E Shareholding Interest in Fangyi Holdings (%)
27. Xing Qibin	Chairman and CEO of Shenzhen Jufei Optoelectronics Co., Ltd. and our Director	625,800	3,129	628,929	1.5
28. Yao Dongwei	Merchant	625,800	3,129	628,929	1.5
29. Zhang Dengsheng	ZTE employee	625,800	3,129	628,929	1.5
30. Cheng Xiao	Merchant	625,800	3,129	628,929	1.5
31. Hou Li	Merchant	625,800	3,129	628,929	1.5
32. Li Yuehua	ZTE employee	625,800	3,129	628,929	1.5
33. Shen Guohong	ZTE employee	625,800	3,129	628,929	1.5
34. Tian Weibing	ZTE employee	625,800	3,129	628,929	1.5
35. Xu Hanwu	Retiree <sup>(4)</sup>	625,800	3,129	628,929	1.5
36. Zhang Chuanhai	Merchant	625,800	3,129	628,929	1.5
37. Zhang Diande	Retiree	625,800	3,129	628,929	1.5
38. Zhou Qingjun	ZTE employee	625,800	3,129	628,929	1.5
39. Liu Weihua <sup>(1)</sup>	Retiree	417,200	2,086	419,286	1
Total:		<u>41,720,000</u>	<u>208,600</u>	<u>41,928,600</u>	<u>100</u>

*Notes:*

- (1) These ten Beneficial Owners have been shareholders of Shenzhen Weixiantong since its establishment in October 1992. The other 29 Beneficial Owners became shareholders of Shenzhen Weixiantong in March 2000. Hence, the shareholders of Shenzhen Weixiantong were those ten Beneficial Owners at the time of establishment of MOBI Shenzhen in August 1999, and the shareholders of Shenzhen Weixiantong made up all of the Beneficial Owners at the time of incorporation of our Company in December 2002. The business scope of Shenzhen Weixiantong is the development and production of communication transmission and ancillary equipment, and also computer and ancillary equipment. The Beneficial Owners have together through Shenzhen Weixiantong or individually with Shenzhen Weixiantong invested in various companies involved in telecommunication and other industries, including ZTE, Kang Cheng, Shenglongfeng as described in the section "Our Relationship with Certain Customers and Suppliers" to this prospectus. As a result of their many years of knowing each other and investing together, the Beneficial Owners have established a long term amicable relationship and a strong degree of mutual trust and bonding among themselves.
- (2) Hu Xiang and Zhou Susu are spouses. Zhou Susu has been the senior vice president of ZTE between 1999 and 2008 and currently a director of ZTE's wholly-owned subsidiary, ZTE (H.K.) Limited.
- (3) Liang Huming and Zhang Yan are spouses.
- (4) The relevant Beneficial Owner was an ex-employee of ZTE or its subsidiaries.

\* The Articles adopted by our shareholders on December 19, 2002 require that all resolutions to be voted at any of our Company's general meetings be decided by poll. Accordingly, and in conjunction with the trust arrangement by the Beneficial Owners, in theory, each of the Beneficial Owners is entitled to direct the common trustees to cast each his/her votes separately in accordance with his/her instruction and the number of Shares so held in trust. However, as confirmed by Qu Deqian and Lai Yongxiang, the ultimate trustee of the Beneficial Owners from December 19, 2002 to September

---

## HISTORY AND DEVELOPMENT

---

28, 2006 and from September 29, 2006 to May 30, 2007 respectively, the relevant trustee was to vote (if required) in the shareholders' meetings of our Company according to the consensus decisions reached amongst the Beneficial Owners. In the absence of a consensus decision amongst the Beneficial Owners, the relevant trustee would not vote on their behalf until a consensus decision had been reached.

Nevertheless, during the relevant period where those Shares were held in trust (i.e. from December 19, 2002 to May 30, 2007), our Company did not hold any general meeting. As a result, the Beneficial Owners had no occasion to exercise their voting rights in the Shares. The Beneficial Owners have allowed the operations of our Company be governed by the Shareholders' Agreement and decided by the board of directors of our Company. As such, the Beneficial Owners jointly effected their "management and control" through the execution of the Shareholder's Agreement and appointment of Directors.

In addition, each of the Beneficial Owners informally discuss matters relating to his/her interests in the Shares amongst the Beneficial Owners and had always been able to arrive at the same decisions even though the Beneficial Owners did not have any voting or other similar agreement in place. These matters include:

- (a) the appointments of Shenzhen Weixiantong, Qu Deqian and Lai Yongxiang as trustees of the relevant Shares,
- (b) use of Shenzhen Weixiantong as a vehicle to represent the interests of the Beneficial Owners as one voice during their negotiation with SB Asia in 2002, and to sign the Shareholders' Agreement, SB Asia's subscription agreement and the Share Warrant for and on behalf of the Beneficial Owners,
- (c) the change of trustees from Qu Deqian to Lai Yongxiang on September 29, 2006,
- (d) the appointment of Lai Yongxiang as trustee of the Warrant Shares,
- (e) the transfer of the relevant Shares from Lai Yongxiang to the Beneficial Owners as registered holders of the Shares on May 31, 2007,
- (f) the appointment of Lai Yongxiang as the first and sole director of Fangyi Holdings on April 11, 2007, and
- (g) the transfer of the relevant Shares from the Beneficial Owners to Fangyi Holdings on January 23, 2008.

It has always been the intention of the Beneficial Owners to reach consensus on all matters relating to their investments in our Company. The Beneficial Owners have always resolved their differences through friendly consultation. The Beneficial Owners attribute their unison of action to the strong degree of mutual trust and understanding among themselves, which had been built up over the many years of their collective investment in various companies in the same pattern as their investment in our Company.

There was no change in the composition of the Beneficial Owners during 2006, 2007, 2008 and the eight months ended August 31, 2009. Seventeen of the Beneficial Owners are members of senior management or employees of ZTE. The following Beneficial Owners are related to us in the manner described below:

- Hu Xiang is an executive Director of our Company, MOBI Shenzhen, MOBI Jian and MOBI Xian, the chairman of the board of Directors, the legal representative of MOBI Shenzhen and MOBI Jian and the chief executive officer of our Company, MOBI Shenzhen and MOBI Jian.
- Zhou Susu is the spouse of Hu Xiang.
- Xing Qibin is a non-executive Director, and a director of MOBI Shenzhen, MOBI Jian and MOBI Xian.
- Qu Deqian is a non-executive Director, a director of MOBI Shenzhen, MOBI Jian and MOBI Xian, and was a nominee shareholder for the Beneficial Owners and Hou Weigui during the period from December 19, 2002 to September 28, 2006.
- Lai Yongxiang was a nominee shareholder for the Beneficial Owners and Hou Weigui during the period from September 29, 2006 to May 30, 2007.
- Lai Yongxiang previously provided advisory services to us with respect to the direction of development in the PRC telecommunication industry and the use of applicable technology and was granted certain options under the 2003 Stock Incentive Plan.
- Hou Weigui was previously a director of MOBI Shenzhen during the period from August 12, 1999 to January 21, 2003.
- Zhu Weimin was previously a director of MOBI Shenzhen during the period from August 12, 1999 to January 21, 2003.

---

## HISTORY AND DEVELOPMENT

---

Other than the foregoing, our Company confirms that none of the Beneficial Owners has any present or past relationship with the Directors, substantial shareholders or members of the senior management of our Company or its subsidiaries or their respective associates or any roles in and positions with us. The Beneficial Owners and SB Asia, throughout 2006, 2007, 2008 and the eight months ended August 31, 2009, together accounted for more than two-thirds of our Company's shareholding prior to Listing. However, none of the Beneficial Owners are acting in concert, either inter se or with SB Asia.

The trust arrangements were of two levels, one where Qu Deqian held those 41,720,000 Shares in trust for the benefit of Shenzhen Weixiantong and the other where Shenzhen Weixiantong held the same interest in those 41,720,000 Shares in trust for the benefit of the Beneficial Owners. The two levels of the trust arrangements were made because:

- (a) SB Asia, our financial investor, was familiar with Shenzhen Weixiantong as an Initial Shareholder of MOBI Shenzhen; as such, the Beneficial Owners arranged to have Shenzhen Weixiantong represent their interests as a trustee of their Shares and as a contracting party signing documents for and on their behalf and were of the view that such arrangement would give the Beneficial Owners better credibility when dealing with SB Asia; and
- (b) Despite the benefits of having Shenzhen Weixiantong represent the interests of the Beneficial Owners, Shenzhen Weixiantong is a PRC corporate entity engaged in day to day business activities with investments in other companies. From an administrative perspective, it would be easier for an individual to implement the instructions of the Beneficial Owners. Therefore, from December 19, 2002 to the date prior to the change of trustee on September 29, 2006, Qu Deqian (being one of the Beneficial Owners) held the relevant Shares in trust for the benefit of Shenzhen Weixiantong, and Shenzhen Weixiantong in turn held the same Shares in trust for the benefit of the Beneficial Owners.

### *SB Asia as our investor and its rights as a holder of Series A Preferred Shares*

On December 19, 2002, our Company entered into a subscription agreement with SB Asia, MOBI Shenzhen, Shenzhen Weixiantong, Qu Deqian, Wang Beirong, Hu Xiang, Wang Guoying, Shao Zhiguo, Hou Weigui and the 39 Employee Shareholders for the subscription of 25.5 million Series A Preferred Shares by SB Asia at a total consideration of RMB45.0 million. Our Directors confirm that the proceeds for the issue of the Series A Preferred Shares were used for the following purposes: (i) RMB15.0 million to acquire the entire equity interest in MOBI Shenzhen; (ii) RMB10.0 million to increase the registered capital of MOBI Shenzhen from RMB3.0 million to RMB13.0 million; and (iii) RMB20.0 million to be retained as our general working capital. SB Asia became our financial investor as the holder of 25.5 million Series A Preferred Shares on January 2, 2003. Please refer to the sub-section headed "Information On Our Financial Investors" of this section of the prospectus for background information on SB Asia. SB Asia subscribed the 25.5 million Series A Preferred Shares at a subscription price of RMB1.7647059 per Series A Preferred Share determined with reference to trading multiple of other publicly traded companies in the same sector at the time. Such subscription price represents a discount of 35.3% to the Offer Price assuming the 25.5 million Series A Preferred Shares have been fully converted into Shares on an one-to-one basis. The discount is calculated on the basis of a conversion price of RMB1.7647059 assuming an Offer Price of HK\$3.11 (being the mid-point of the Offer Price between HK\$2.72 and HK\$3.50 per Offer Share) and an exchange rate of RMB1.00 converted to HK\$1.14.

On December 19, 2002, the Shareholders' Agreement was entered into among our Company, MOBI Shenzhen, SB Asia, Shenzhen Weixiantong, Qu Deqian, Wang Beirong, Hu Xiang, Wang Guoying, Shao Zhiguo, Hou Weigui and the 39 Employee Shareholders (who are distinct from the Beneficial Owners) and the Articles were adopted on December 19, 2002, setting out their key rights and obligations as shareholders of our Company as follows:

- (a) SB Asia, being a holder of Series A Preferred Shares (the "Series A Shareholder"), was granted, among other things, pre-emptive rights, rights of first refusal, co-sale rights, various consent rights, and various information access and consultation rights.

---

## HISTORY AND DEVELOPMENT

---

- (b) For so long as SB Asia directly or indirectly owns at least 25% of the Shares issued or issuable upon conversion of Series A Preferred Shares on an as converted basis, SB Asia is entitled to appoint two Directors and all committees (including the board finance committee) of our Company's board of directors must include at least one Director so appointed by SB Asia as a committee member.
- (c) For so long as Qu Deqian (for and on behalf of ultimately the Beneficial Owners through Shenzhen Weixiantong), Wang Beirong, Hu Xiang, Wang Guoying, Shao Zhiguo, Hou Weigui and the 39 Employee Shareholders (the "Founding Shareholders") own in aggregate directly or indirectly at least 51% of all voting power of our Company, the Founding Shareholders are entitled to appoint four Directors (and our Company confirms that in practice the Beneficial Owners appoint three Directors (namely, Hu Xiang, Qu Deqian and Xing Qibin) and our remaining shareholders who are the Founding Shareholders (namely Wang Guoying, Shao Zhiguo and the 39 Employee Shareholders) appoint one Director (namely, Wang Guoying)).
- (d) For so long as sub-paragraphs (b) and (c) above are applicable, SB Asia and the Founding Shareholders are entitled to jointly appoint one independent Director (namely, Li Tianshu).
- (e) For so long as Shenzhen Weixiantong (for and on behalf of the Beneficial Owners) owns directly or indirectly at least one-third of all voting power of our Company, Shenzhen Weixiantong (for and on behalf of the Beneficial Owners) is entitled to nominate (i) a person to the position of the chief executive officer of our Company and each of our subsidiaries, and (ii) one member of the board finance committee (and such board finance committee shall comprise three members with our chief executive officer being a member and any other member to be appointed by our board of directors). If Shenzhen Weixiantong (for and on behalf of the Beneficial Owners) is not qualified to make such nomination, the aforesaid positions of chief executive officer shall be nominated by our board of directors. All other positions of the senior management of our Company and our subsidiaries shall be nominated by the chief executive officer then in office.
- (f) For so long as sub-paragraph (b) above is applicable, nomination of the aforesaid senior management shall be subject to the veto right of SB Asia (so long as SB Asia directly or indirectly owns at least 25% of the Shares issued or issuable upon conversion of Series A Preferred Shares on an as converted basis) and be only filled with the prior approval of our board of directors.
- (g) Directors of each subsidiary of our Company shall be appointed and removed by our board of directors subject to the approval of holders of not less than two-thirds of Shares (on an as converted basis) held by the Founding Shareholders and the Series A Shareholders.

According to the Articles adopted on December 19, 2002, each Series A Preferred Share is convertible at no additional consideration at any time at the option of the holder into such number of Shares as determined by dividing RMB1.7647059 by a conversion price (the "Conversion Price"), which will initially be RMB1.7647059 per share (subject to applicable adjustment). Series A Preferred Shares will also be automatically converted to Shares at the Conversion Price upon (i) occurrence of a firmly underwritten initial public offering, managed by an investment bank of recognized high standing, with total offering proceeds (excluding the proceeds of any securities issued by our Company to signatories to the Shareholders' Agreement) of not less than US\$6.0 million or its equivalent (before deduction of underwriters commissions and expenses) and with a pre-offering valuation of our Company of not less than US\$30.0 million; and (ii) the listing of the Shares on an internationally reputable stock exchange reasonably acceptable to the Series A Shareholders who own, in aggregate, at least 51% of all issued and outstanding Series A Preferred Shares (a "Qualified IPO").

---

## HISTORY AND DEVELOPMENT

---

As stipulated in the Articles adopted on December 19, 2002, each Share confers upon its shareholder the right to one vote and the holder of each Series A Preferred Share has the number of votes equal to the number of Shares into which such Series A Preferred Share could be converted to at the record date, or if no record date is established, at the date the vote is taken or at the date when any written consent of the shareholders is solicited. Resolutions to be voted at any general meetings of our Company must, in all cases, be decided by poll. Poll votes may be given either personally or by proxy. The chairman of the general meeting is not entitled to a second or casting vote. Furthermore, as stipulated in the Articles adopted on December 19, 2002, written consent of holders of at least two-third of the outstanding Series A Preferred Shares (or holders of more than three-fourth of the outstanding Series A Preferred Shares for so long as at least one-fourth of all Series A Preferred Shares issued remain outstanding and unconverted) is required for: (i) any amendment or change to the rights, preferences, privileges or powers of, or the restrictions provided for the benefit of, the Series A Preferred Shares; (ii) any action that authorizes, creates or issues shares of any class having preferences superior to or on a parity with the Series A Preferred Shares; (iii) any action that reclassifies any outstanding shares into shares having preferences or priority as to dividends or assets superior to or on a parity with the Series A Preferred Shares; (iv) any amendment of the Articles or the memorandum of association of our Company that increases or decreases the number of authorized directors or that adversely affects the rights of any holder of Series A Preferred Shares; and (v) any redemption or repurchase by our Company of its outstanding shares other than the repurchase or conversion of Series A Preferred Shares as set forth in the Articles.

No dividends or other distributions may be made or declared in property, or in any other shares of our Company, with respect to any other class or series of shares of our Company apart from the Series A Preferred Shares, unless and until dividends or distributions in like amount have been paid or distributed in full on the Series A Preferred Shares on an as-converted basis.

In the event of any liquidation, dissolution or winding up of our Company, the Series A Shareholders are entitled to receive, prior and in preference to any distribution of any of the assets or surplus funds of our Company to the holders of the Shares or any other class or series of shares, an amount equal to RMB1.7647059 (subject to applicable adjustment) for each Series A Preferred Share and, in addition, all declared but unpaid dividends (the "Series A Preference Amount"). After full payment of the Series A Preference Amount in respect of each Series A Preferred Share, any remaining assets or surplus funds of our Company are required to distribute pro rata to the holders of Shares and Series A Preferred Shares on an as-converted basis.

Since becoming a shareholder of our Company, SB Asia has exercised the following key rights under the Articles adopted on December 19, 2002 Shareholders' Agreement:

- (a) appointment of Yan Andrew Y. and Huang Jinsheng as directors of our Company on January 2, 2003;
- (b) appointment of Huang Jinsheng as representative of SB Asia on our Company's board finance committee on January 2, 2003;
- (c) appointment of Liu Jianping as independent non-executive director of our Company on September 8, 2003 (such appointment was jointly made with other shareholders of our Company). Mr. Liu resigned as director of the Company on July 1, 2007 and Mr. Li Tianshu replaced him as independent non-executive director on the same date;
- (d) consent to declaration and payment of dividends in 2004, 2006, 2008 and 2009 by way of board resolutions;
- (e) appointment of Yang Dong as a director of our Company, and as a representative of SB Asia on our Company's board finance committee, in place of Huang Jinsheng on March 28, 2006;
- (f) consent to establish MOBI Jian on May 23, 2006 and MOBI Xian on April 29, 2008 by way of board resolutions;

---

## HISTORY AND DEVELOPMENT

---

- (g) consent to amendment of the articles of MOBI Shenzhen as a result of the increase in its registered capital from RMB13.0 million to RMB30.0 million on May 11, 2007 by way of board resolution; and
- (h) various information rights from time to time with respect to our financial information.

Amended and restated Articles adopted by our shareholders on November 25, 2009 will take effect on the Listing Date and pursuant to our new Articles, the share capital of our Company will consist of only one class of shares and no preferred shares upon Listing. The Shareholders' Agreement will be terminated in its entirety effective on Listing Date pursuant to a termination agreement to be entered into by shareholders of our Company. As a result, the above-mentioned special rights accorded to SB Asia as a Series A Shareholder set out under the Shareholders' Agreement and the Articles adopted on December 19, 2002 will be terminated upon Listing.

### *Issuance of the Warrants*

On December 19, 2002, our Company also issued the Series A Preferred Share Warrant to SB Asia. Pursuant to the Series A Preferred Share Warrant, SB Asia is entitled to acquire during the exercise period such number of Series A Preferred Shares as is equal to a total consideration of RMB9.0 million divided by an initial exercise price of RMB1.7647059 (subject to applicable adjustment). The exercise period of the Series A Preferred Share Warrant shall expire at the earliest of (a) January 2, 2013, (b) the Listing Date, (c) the date of liquidation, dissolution or winding up of our Company, and (d) the date of full redemption of SB Asia's Series A Preferred Shares by our Company as provided under our Articles. The Series A Preferred Share Warrant was part of SB Asia's investment package that provided SB Asia with a right to acquire additional Series A Preferred Shares during the exercise period of the Series A Preferred Share Warrant. As a parallel to the Series A Preferred Share Warrant, the Beneficial Owners also negotiated for the grant of the Share Warrant. On December 19, 2002, the Share Warrant was granted to Shenzhen Weixiantong acting for and on behalf of the Beneficial Owners. Pursuant to the Share Warrant, Shenzhen Weixiantong, acting for and on behalf of the Beneficial Owners, is entitled to acquire 208,600 Shares at a consideration of US\$1.00 during the exercise period, which expired on the date being one and a half year from the date of incorporation of our Company and which was subsequently extended to December 18, 2006 by way of our directors' resolutions.

### *Acquisition of MOBI Shenzhen*

On December 19, 2002, our Company entered into an equity transfer agreement with the Initial Shareholders for the acquisition of the entire equity interest in MOBI Shenzhen at a consideration of RMB15.0 million. On January 21, 2003, MOBI Shenzhen was converted into a wholly foreign-owned enterprise of our Company.

For details regarding our restructuring, see "Corporate reorganization" in Appendix VI to this prospectus.

## HISTORY AND DEVELOPMENT

The diagram below sets forth our shareholding and corporate structure immediately after completion of the Reorganization:

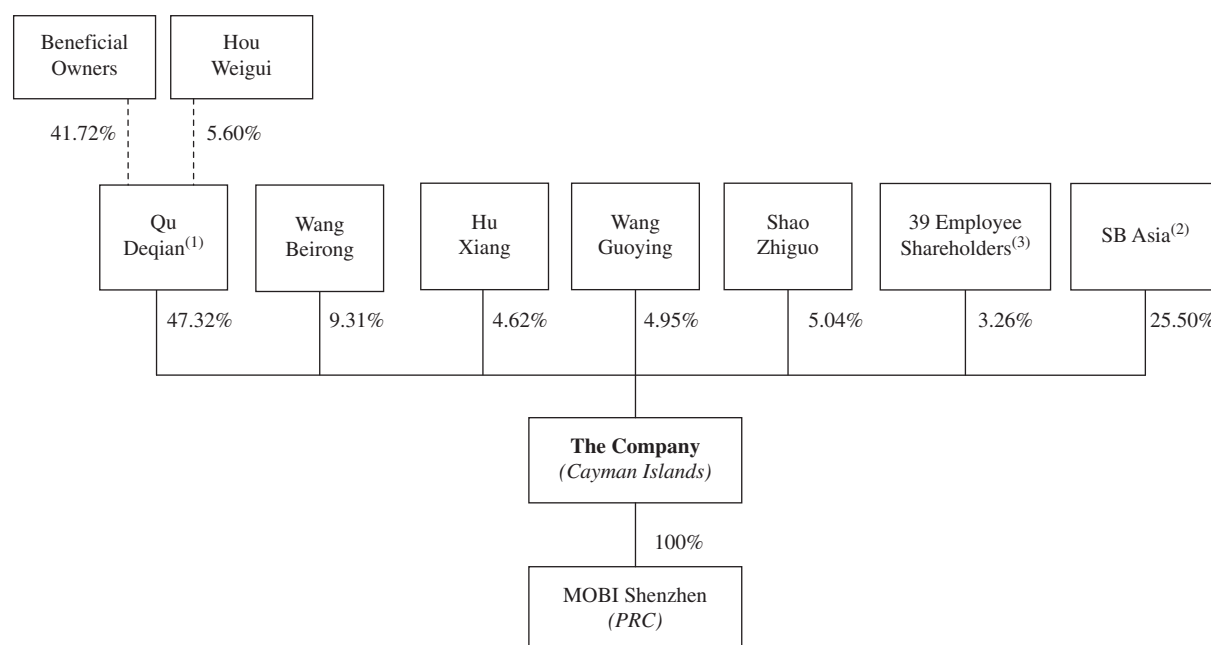

*Notes:*

- (1) Qu Deqian was a nominee shareholder, holding 41,720,000 Shares and 5,602,400 Shares in trust ultimately for the Beneficial Owners through Shenzhen Weixiantong, and in trust for Hou Weigui respectively.
- (2) SB Asia held 25.5 million Series A Preferred Shares, which will be converted into 25.5 million Shares on the Listing Date at no additional consideration.
- (3) We confirm that as of the Latest Practicable Date, the 39 Employee Shareholders do not have any relationship with our Group other than being employees or consultants of our Group, and that the 39 Employee Shareholders are not related to other shareholders of our Company and are not related to one another.

### Post-reorganization Developments

#### *Cisco and Manitou as our investors*

On September 12, 2003, Wang Beirong transferred his entire equity interest, consisting of 7,018,348 Shares (the “Cisco Shares”) and 2,294,152 Shares (the “Manitou Shares”), to Cisco and Manitou respectively. In this connection, our Company issued a letter to Cisco and Manitou (the “Cisco and Manitou Letter”) to define their respective rights and obligations as shareholders of our Company. Pursuant to the Cisco and Manitou Letter, for so long as Cisco holds more than 50% of the Cisco Shares (subject to applicable adjustment) (the “Adjusted Cisco Shares”), Cisco has the right to appoint an observer to attend all meetings of our Company’s board of directors and the right to access to materials of such meetings. For so long as Cisco holds more than 50% of the Adjusted Cisco Shares, and for so long as Manitou holds more than 50% of the Manitou Shares, each of Cisco and Manitou is entitled to various information rights. Pursuant to a letter dated November 27, 2009 issued by our Company and acknowledged by Cisco and Manitou, the above-mentioned special rights accorded to Cisco and Manitou as shareholders of our Company set out under the Cisco and Manitou Letter will be terminated upon Listing.

---

## HISTORY AND DEVELOPMENT

---

### *Establishment of MOBI Jian and MOBI Xian*

On May 23, 2006, MOBI Jian, a wholly owned subsidiary of our Company, was established as a limited liability company under the PRC laws. MOBI Jian is engaged in the manufacture and sales of mobile communication network base station antennas and other antennas, RF devices and components and RF cables for PHS, GSM, CDMA, TDS-CDMA, WCDMA and CDMA2000 protocols.

On April 29, 2008, MOBI Shenzhen established its wholly-owned subsidiary, MOBI Xian, as a limited liability company under the laws of the PRC. MOBI Xian is engaged in research, development and production of mobile communication network base station antennas, RF devices and components for GSM, CDMA, TDS-CDMA, WCDMA and CDMA2000 protocols.

### *Lai Yongxiang as trustee*

On September 29, 2006, Qu Deqian transferred to Lai Yongxiang the 41,720,000 Shares he held in trust ultimately for the Beneficial Owners at a nominal consideration of US\$1.00, and the 5,602,400 Shares he held in trust for Hou Weigui at a nominal consideration of US\$1.00. On January 23, 2008, the 41,720,000 Shares of the Beneficial Owners were transferred to Fangyi Holdings, a British Virgin Islands vehicle owned by the Beneficial Owners and Lai Yongxiang (one of the Beneficial Owners) is a director of Fangyi Holdings. Given that Lai Yongxiang is the sole director of Fangyi Holdings representing the interests of the Beneficial Owners as shareholders of Fangyi Holdings upon Listing, the change of trustee from Qu Deqian to Lai Yongxiang in September 2006 was to facilitate Lai Yongxiang's representation of the Beneficial Owners' interests in preparation of the Listing.

Pursuant to two declarations of trust dated September 29, 2006, Lai Yongxiang held those 41,720,000 Shares in trust for the benefit of Shenzhen Weixiantong and those 5,602,400 Shares in trust for the benefit of Hou Weigui, respectively. Pursuant to a declaration of trust dated May 16, 2007, Shenzhen Weixiantong confirmed and acknowledged that any interest in those 41,720,000 Shares had always been held in trust for the Beneficial Owners. As confirmed by our Directors, the 41,720,000 Shares were held by Qu Deqian in trust ultimately for the Beneficial Owners during the period from December 19, 2002 to September 28, 2006 and by Lai Yongxiang in trust ultimately for the Beneficial Owners during the period from September 29, 2006 to May 30, 2007. Our Directors also confirm that those 5,602,400 Shares were held by Qu Deqian in trust for Hou Weigui during the period from December 19, 2002 to September 28, 2006 and by Lai Yongxiang in trust for Hou Weigui during the period from September 29, 2006 to May 30, 2007. Hence, the Beneficial Owners and Hou Weigui have since December 19, 2002 continued to be the beneficial owners of 41,720,000 Shares and 5,602,400 Shares, respectively, notwithstanding Qu Deqian transferred those 47,322,400 Shares to Lai Yongxiang. As advised by our legal advisers as to PRC laws, the aforesaid trust arrangements were not in conflict with any of the PRC trust laws and regulations.

### *Exercise of the Warrants*

On December 18, 2006, Shenzhen Weixiantong, acting for and on behalf of the Beneficial Owners, exercised the Share Warrant and directed the underlying shares of the Share Warrant, being 208,600 Shares, be issued to Lai Yongxiang at an exercise price of US\$1.00. Such subscription price represents approximately 100% discount to an Offer Price of HK\$3.11 (being the mid-point of the Offer Price between HK\$2.72 and HK\$3.50 per Offer Share). The discount is calculated on the basis of an exercise price of US\$1.00 for a total of 208,600 Shares and an exchange rate of US\$1.00 converted to HK\$7.80. On April 20, 2007, 208,600 Shares were issued to Lai Yongxiang, who held such Shares pursuant to a declaration of trust dated May 14, 2007 in trust for the Beneficial Owners in the proportion set forth in column C of the chart entitled "Summary on the Beneficial Owners" in this section of the prospectus.

---

## HISTORY AND DEVELOPMENT

---

On December 18, 2006, SB Asia exercised the Series A Preferred Share Warrant at a total purchase price of RMB8,999,998.33 (as agreed by our Company through directors' resolutions) and was issued 5,099,999 Series A Preferred Shares on April 20, 2007. Together with the 25,500,000 Series A Preferred Shares already held by SB Asia, a total of 30,599,999 Series A Preferred Shares will be converted into 30,599,999 Shares on the Listing Date at no additional consideration.

### *Increase of registered capital of MOBI Shenzhen*

On May 11, 2007, the registered capital of MOBI Shenzhen was further increased from RMB13.0 million to RMB30.0 million. The increased registered capital of RMB17.0 million was fully paid up.

### *Termination of trust arrangements*

On May 31, 2007, Lai Yongxiang transferred 41,928,600 Shares and 5,602,400 Shares to the Beneficial Owners and Hou Weigui respectively pursuant to their directions. No formal agreements have been entered into between Lai Yongxiang and the Beneficial Owners, and Lai Yongxiang and Hou Weigui to terminate the declarations of trust. As no agreement is necessary to record the relevant declarations of trust, the trust arrangements have been automatically terminated as a result of the transfer of the trust property to the Beneficial Owners and Hou Weigui respectively on May 31, 2007. Following the share transfers from Lai Yongxiang, each of the Beneficial Owners and Hou Weigui became the registered shareholders of our Company on May 31, 2007. Each of the Beneficial Owners directly held the number of Shares as set forth next to his/her name in column D of the chart entitled "Summary on the Beneficial Owners" in this section of the prospectus.

### *Share transfers after the termination of trust arrangements*

On January 23, 2008, each of the Beneficial Owners transferred each of his or her entire shareholding in our Company, being 41,928,600 Shares in total, to Fangyi Holdings, a limited liability company incorporated in the BVI on April 11, 2007 and owned by the Beneficial Owners in the proportion set forth in column E of the chart entitled "Summary on the Beneficial Owners" in this section of the prospectus.

On January 23, 2008, Hou Weigui transferred his 5,602,400 Shares to Junyi Holdings, a limited liability company incorporated in the BVI on January 31, 2007 and wholly owned by Hou Weigui himself. As a result, the Beneficial Owners and Hou Weigui indirectly hold 41,928,600 Shares and 5,602,400 Shares through their respective investment companies, Fangyi Holdings and Junyi Holdings.

On January 24, 2008, each of the 39 Employee Shareholders transferred to Shao Zhiguo each of their entire shareholding (both registered and beneficial interests) in our Company, being 3,255,650 Shares in total, at a consideration of RMB8,139,125, which was determined with reference to the net asset value of the Group as of August 31, 2007 of approximately RMB263,458,000.

### *Termination of Shareholders' Agreement*

On November 27, 2009 in contemplation for the Listing, SB Asia, Cisco, Manitou, Fangyi Holdings, Junyi Holdings, Hu Xiang, Wang Guoying and Shao Zhiguo, all being shareholders of our Company immediately prior to Listing, entered into a termination agreement with our Company and MOBI Shenzhen for the purpose of terminating the Shareholders' Agreement in its entirety effective on the Listing Date. Amended and restated Articles adopted by our shareholders on November 25, 2009 will take effect on the Listing Date and pursuant to our new Articles the share capital of our Company will consist of only one class of shares and no preferred shares upon Listing.

---

## HISTORY AND DEVELOPMENT

---

### *Fangyi Holdings and its shareholders*

Fangyi Holdings will not be entitled to exercise or control the exercise of 30% or more of the voting power at general meetings of our Company and will not be in a position to control the composition of a majority of the board of the directors of our Company after Listing. Fangyi Holdings will be our single largest shareholder immediately following the Global Offering and conversion of all outstanding Series A Preferred Shares into Shares, assuming none of the Over-allotment Option, the Pre-IPO Options, and options that may be granted under the Share Option Scheme has been exercised. None of the Beneficial Owners is entitled to exercise or control the exercise of one-third or more of the voting power at the general meetings of Fangyi Holdings on an individual basis. Therefore, the individual shareholding interests of the Beneficial Owners in our Company is not required to be disclosed under the provisions of Divisions 2 and 3 of Part XV of the SFO. However, for the purposes of Rule 10.07 of the Listing Rules, Fangyi Holdings and the Beneficial Owners are treated as controlling shareholders of our Company upon Listing and subject to the undertakings set forth in the subsection headed “Undertakings” in the section headed “Underwriting” to this prospectus. Pursuant to a letter of understanding dated January 23, 2008 (the “Letter”), the Beneficial Owners shall reach consensus and arrive at the same decision on all matters relating to the investment of Fangyi Holdings in our Company. In the event of any disagreement among the Beneficial Owners on such matters, the Beneficial Owners shall engage in friendly consultation (whether in shareholders’ meetings of Fangyi Holdings or otherwise) with a view to resolving all their differences without disrupting our Company’s operation. The Letter will take effect on the date of Fangyi Holdings becoming a shareholder of our Company and terminate on the date when Fangyi Holdings disposes of all of its equity interests in our Company.

### *PRC legal compliance*

Our legal advisers as to PRC laws have advised us that the Global Offering and the proposed Listing are not subject to any approval or consent by the CSRC and other PRC government authorities, and that our Company has complied with all relevant rules, regulations and registration requirements imposed by the relevant PRC authorities (including the SAFE), and where applicable, obtained all necessary approvals and consents in relation to its Reorganization and Global Offering, including but not limited to, the Notice of on Issues relating to Foreign Exchange Control on Fund Raisings by Domestic Residents through Offshore Special Purpose Vehicles and Round-trip Investments promulgated by the SAFE on October 21, 2005 (the “SAFE Notice”). According to the SAFE Notice, Shao Zhiguo, Wang Guoying and the Beneficial Owners who are PRC residents shall effect supplementary foreign exchange registration of offshore investments with the local foreign exchange bureau by March 31, 2006. Given the fact that such PRC residents were residing in different places and countries, it took our Company a substantial amount of time to contact each of such PRC residents and prepare the required documents for such foreign exchange registration, causing delay in the registration process. As of the Latest Practicable Date, our legal advisers as to PRC laws confirmed that all necessary foreign exchange registrations of offshore investments in relation to our Company have been completed at the Shenzhen branch of the SAFE on June 5, 2007. As of the Latest Practicable Date, we have been advised by our legal advisers as to PRC laws that no punitive provisions are set forth in the SAFE Notice for delay in such foreign exchange registrations, and that the Shenzhen branch of the SAFE has not imposed any penalty or other form of punishment on the said PRC residents for their delay in registration.

According to the Rules on Acquisition of Domestic Enterprises by Foreign Investors (the “M&A Rules”) jointly promulgated by the Ministry of Commerce, the State-owned Assets Supervision and Administration Commission of the State Council, the State Administration of Taxation, the SAIC, the CSRC and the SAFE on August 8, 2006 and effective as of September 8, 2006 (the “Effective Date”), an offshore special purpose vehicle formed for overseas listing purpose and controlled, directly or

---

## HISTORY AND DEVELOPMENT

---

indirectly by PRC domestic enterprise(s) or individual(s), in the event that such special purpose vehicle acquires equity interests in PRC domestic enterprise(s) in exchange for the shares of offshore companies, is required to obtain approval from the CSRC for its overseas listing,

In addition, according to the Notice of the State Council on Further Strengthening Administration of Overseas Offerings and Listings) promulgated on June 20, 1997 (the “State Council Notice”), offshore public companies controlled by domestic enterprises with equity interests in which are held by domestic enterprises are required to obtain approval from the CSRC for its overseas listing.

As advised by our legal advisers as to PRC laws, based on their understanding of current PRC laws, regulations and rules, neither the M&A Rules nor the State Council Notice shall apply to our Company, and the listing of the Shares on the Stock Exchange does not require the approval by the CSRC on the following basis:

- (1) We completed our acquisition of MOBI Shenzhen, a PRC domestic enterprise, in 2002 before the Effective Date by means of cash consideration which did not involve any exchange of shares of our Company. The M&A Rules do not provide that it shall apply retroactively on acquisitions (including our acquisition by means of cash consideration) that have been completed before the Effective Date; and
- (2) The ultimate holders of the equity interests in our Company are domestic individuals rather than domestic enterprises.

### INFORMATION ON OUR FINANCIAL INVESTORS

SB Asia, Cisco and Manitou are financial investors who have invested in our Company. SB Asia will be a substantial shareholder of our Company upon Listing. Yan Andrew Y. and Yang Dong were nominated by SB Asia as our Directors. We do not have any past or current business relationship with SB Asia. We confirm each of Cisco and Manitou is an Independent Third Party without any past or current business relationship with us.

#### **SB Asia**

SB Asia is a US\$404 million fund established under the laws of Cayman Islands in 2001 and managed by SOFTBANK, Inc. SAIF Advisors Limited is an investment advisor to SAIF Management II Limited. Our Director, Yan Andrew Y., was the founder of and has been the managing partner of SAIF Advisors Limited since 2001, and our Director, Yang Dong, is currently a partner at an affiliate of SAIF Advisors Limited.

SB Asia makes privately negotiated equity or equity-linked investments mainly in information technology, media and telecom related companies based or with significant operations in the Asia Pacific region. SB Asia focuses its efforts primarily on the PRC, India, Korea, Hong Kong and Taiwan.

As confirmed by SB Asia, SB Asia is a limited partnership with one general partner, SB Asia Pacific Partners L.P. and one limited partner, Asia Infrastructure Investments Limited. SB Asia also confirms that the sole general partner of SB Asia Pacific Partners L.P. is SB Asia Pacific Investments Limited, and that Asia Infrastructure Investments Limited is owned as to 99% by Cisco Systems, Inc. (the parent company of Cisco) and as to 1% by SB First Singapore Pte Ltd.. Cisco Systems, Inc. is a company listed on NASDAQ Global Select Market. As confirmed by SB Asia, SOFTBANK CORP., a company listed on the Tokyo Stock Exchange, is the sole shareholder of SB First Singapore Pte Ltd., and Asia Infrastructure Investments Limited is the sole shareholder of SB Asia Pacific Investments Limited. SB Asia also confirms that Cisco Systems, Inc. only has economic interest but no management rights, voting rights or significant influence on Asia Infrastructure Investments Limited

---

## HISTORY AND DEVELOPMENT

---

and that as a limited partner of SB Asia, Asia Infrastructure Investments Limited only has economic interest but no management rights, voting rights or significant influence on SB Asia. Save for the foregoing, SB Asia confirms that there is no other relationship between SB Asia and Cisco and its holding companies. For the purposes of the SFO disclosure, a general partner (but not a limited partner) in a limited liability partnership equates to a controlling shareholder of a corporation and will be deemed to be interested in the limited liability partnership. It follows that for the purposes of the SFO disclosure, Cisco Systems, Inc. will not be deemed to be interested in SB Asia by virtue of its equity interests in the limited partner of SB Asia. As confirmed by SB Asia and Cisco, they are not parties acting in concert for the purposes of the Takeovers Code. In view of the above, the equity interests of SB Asia and Cisco in our Company should not be aggregated. SB Asia does not act in concert with any of the Beneficial Owners.

### **Cisco**

Cisco, a private company with limited liability incorporated under the laws of the Netherlands, is a wholly-owned subsidiary of Cisco Systems, Inc. Cisco Systems, Inc. is a leader in the innovation of Internet Protocol (IP)-based networking technologies and the development of routing and switching and numerous advanced technologies including application networking services, collaboration, home networking, security, storage area networking, telepresence systems, unified communications, unified computing, video systems and wireless.

### **Manitou**

Manitou is a venture fund established in 2001 under the laws of the State of Delaware, the United States and managed by Manitou Venture Management I, LLC. Manitou invests in early and mid-stage companies, based either in Asia or the United States, with a focus on Asian markets such as the PRC and Taiwan. The primary investment focus of Manitou is high growth technology sectors including telecommunications, internet, new media, semiconductors and information technology services.

---

## HISTORY AND DEVELOPMENT

---

### CORPORATE STRUCTURE

Among our shareholders, as of the Latest Practicable Date, only Cisco and Manitou are not connected persons (as defined under the Listing Rules) of our Group and can be considered as members of the public. Except for those Shares held by Cisco and Manitou, which will be counted towards public float, all the other Shares will not be counted as listed securities held by the public upon Listing.

All of our shareholders (as of the Latest Practicable Date) have given undertakings on the holding of their Shares. Please refer to the subsection headed “Undertakings” in the section headed “Underwriting” to this prospectus for further details.

The diagram below sets forth our shareholding and corporate structure immediately before the Global Offering.

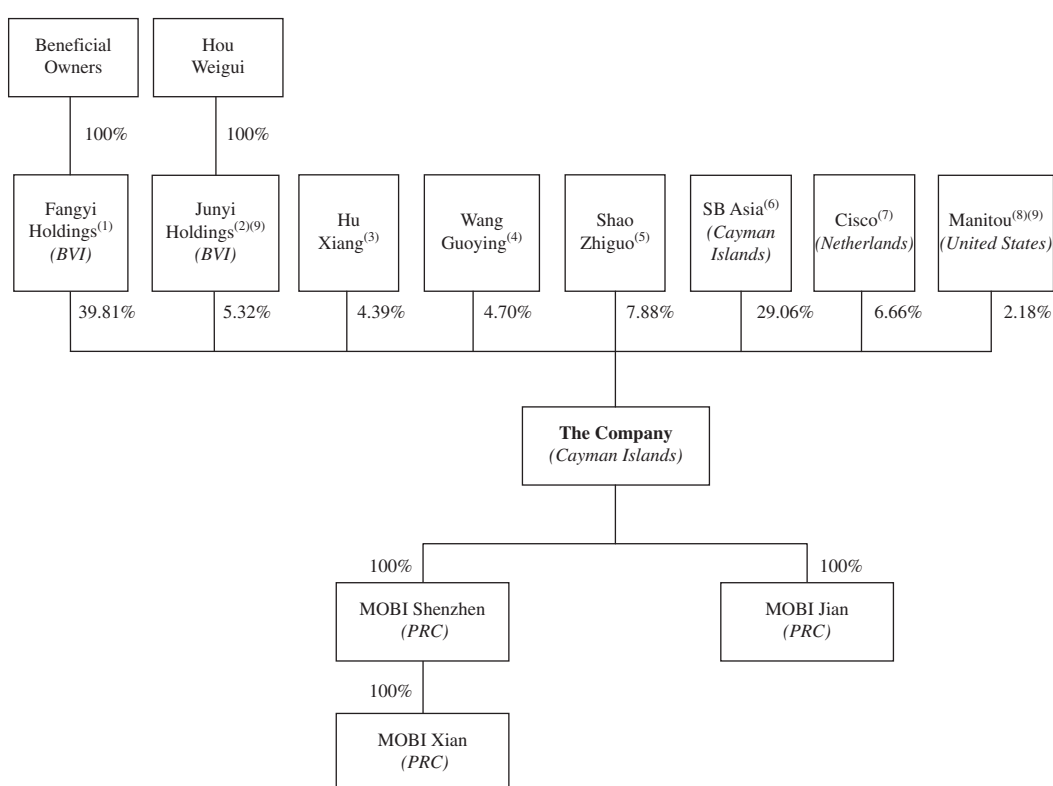

## HISTORY AND DEVELOPMENT

The diagram below sets forth our shareholding and corporate structure immediately following the Global Offering and conversion of all outstanding Series A Preferred Shares into Shares, assuming none of the Over-allotment Option, the Pre-IPO Options, and options that may be granted under the Share Option Scheme has been exercised.

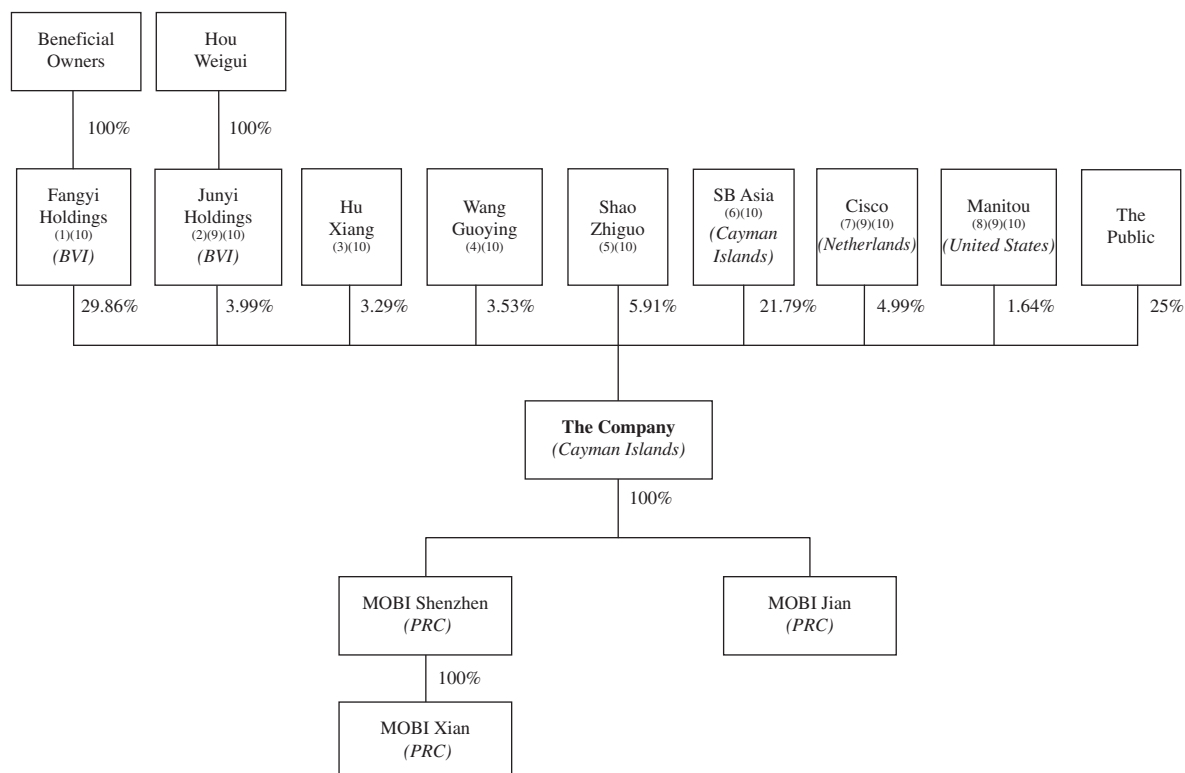

*Notes:*

- (1) Fangyi Holdings is an investment holding company owned by the Beneficial Owners.
- (2) Junyi Holdings is an investment holding company whose share capital is wholly owned by Hou Weigui, one of the Beneficial Owners.
- (3) Hu Xiang is an executive Director of our Company, MOBI Shenzhen, MOBI Jian and MOBI Xian, the chairman of the board of Directors, the legal representative of MOBI Shenzhen and MOBI Jian and the chief executive officer of our Company, MOBI Shenzhen and MOBI Jian.
- (4) Wang Guoying is an executive Director, a director of MOBI Shenzhen, MOBI Jian and MOBI Xian and chief executive officer of MOBI Xian.
- (5) Shao Zhiguo is the vice president of our Company, MOBI Shenzhen and MOBI Jian.
- (6) SB Asia is a fund established under the laws of Cayman Islands in 2001.
- (7) Cisco is a limited liability company incorporated under the laws of the Netherlands. Cisco is wholly owned by Cisco Systems, Inc.
- (8) Manitou is a fund established under the laws of the State of Delaware, the United States in 2001.
- (9) The Shares held by Cisco and Manitou will be counted as listed securities held by the public upon Listing in addition to the 25% shareholding held by the public.
- (10) All of our shareholders (as of the Latest Practicable Date) have given undertakings on the holding of their Shares. Please refer to the subsection headed “Undertakings” in the section headed “Underwriting” to this prospectus for further details.

---

## BUSINESS

---

### OVERVIEW

We are one of the few one-stop providers of wireless communication antennas and base station RF subsystems in China. By strategically locating our principal operations in China, we aim to capitalize on its fast growing mobile communication and equipment manufacturing industry that supplies the rapidly growing worldwide demand for mobile communication infrastructure equipment. Our business consists of the design, manufacture, marketing and sale of antennas, base station RF subsystem and solutions that are the required components of mobile communication coverage systems, including, wireless access systems (WiFi and PHS), 2G (GSM and CDMA), 3G (TD-SCDMA, CDMA 2000, W-CDMA and WiMax), satellite communication and microwave transmission networks. Our product portfolio is categorized into three principal groups: antenna systems, base station RF subsystems and coverage extension solutions. We sell our products to network operators in China and overseas directly for deployment into the networks they are constructing and operating. We also sell our products to wireless network solution providers who incorporate our products into their wireless coverage solutions, such as their proprietary base stations, which they then sell to network operators worldwide.

Our sophisticated technical skills and design experience in developing antennas and base station RF subsystems enable us to be qualified as an equipment supplier to some of the world's leading wireless network solution providers, such as ZTE, Nokia Siemens Networks and Alcatel-Lucent. We also focus our marketing strategy on expanding our market share in China and certain international markets, particularly the rapidly growing emerging market countries that represent some of the greatest growth opportunities in the construction of wireless communication infrastructure, as wireless networks offer a highly cost effective way of establishing communication infrastructure in these regions.

We are committed to providing quality and sophisticated products and building long term relationships with our customers. For the years ended December 31, 2006, 2007, 2008 and the eight months ended August 31, 2009, our revenues were approximately RMB361.0 million, RMB626.8 million, RMB671.2 million and RMB632.4 million, respectively. Our net profits for the same periods were approximately RMB31.5 million, RMB56.8 million, RMB61.9 million and RMB84.2 million, respectively.

### The RF path

Our core competency is the design and manufacture of technology employed in the RF path of a communication network. The first stage of the RF path connects the core system of a network operator to base stations of a wireless communication system, and to switching centers of a fixed-line communication system. This stage of the communication can be transmitted either through fiber optic cables or microwave transmission. In microwave transmission, a directional microwave antenna, such as the ones we design and manufacture, is utilized. From the base station, the RF signal is further transmitted to individual wireless access systems (WiFi and PHS), 2G (GSM and CDMA), 3G (TD-SCDMA, CDMA2000, W-CDMA and WiMax) networks and to the mobile handsets. Where the signal is weak or cannot be established directly, coverage extension solutions can also be employed to repeat and amplify the signal.

---

## BUSINESS

---

The following diagram illustrates the RF path.

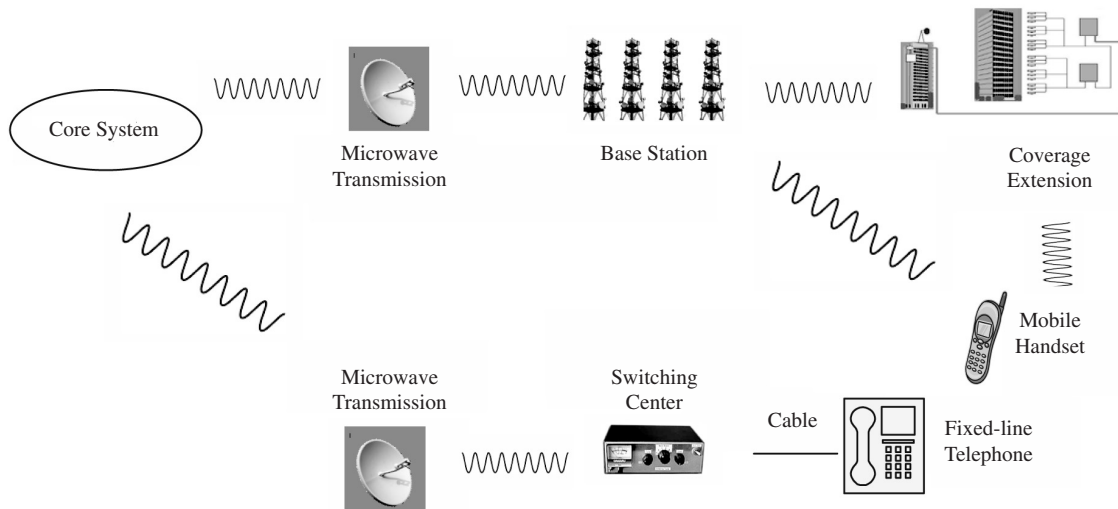

### The Wireless Infrastructure Supply Chain

We sell most of our antenna system and base station RF subsystem products to wireless network solution providers, such as ZTE, Nokia Siemens Networks and Alcatel-Lucent, who incorporate our products into their wireless coverage solutions, such as their proprietary base stations, which they then sell to network operators worldwide. We also sell our antenna system products, base station RF subsystem products and most of our coverage extension solution products to network operators in China and overseas for deployment into the networks they are constructing. A small portion of our coverage extension solution products is sold to other coverage extension solution providers whose product portfolio is more limited than ours or do not have the capacity to provide such products or for other reasons.

The following diagram illustrates the supply chain for wireless communication infrastructure.

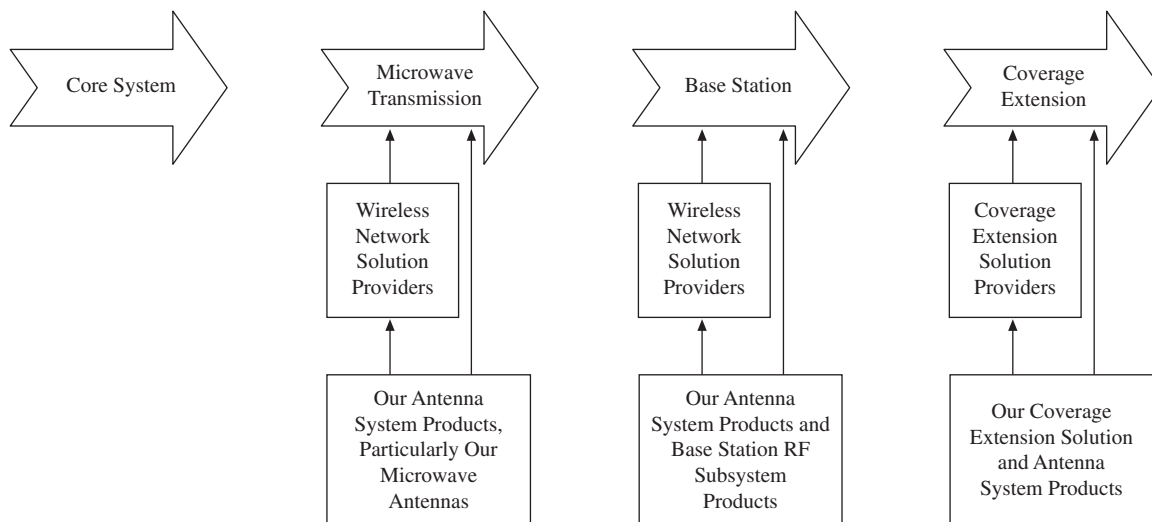

---

## BUSINESS

---

### COMPETITIVE STRENGTHS

#### **Strong relationships with all the PRC domestic wireless network operators and many of the world's leading wireless network solution providers**

We have strong, long-term relationships with all the PRC domestic wireless network operators, including China Mobile, China Unicom and China Telecom since 2001, 2001 and 2002, respectively, and have fostered commercial relationships with certain overseas wireless network operators, such as Reliance, India's second largest wireless operator, beginning in early 2007. We have also maintained our established relationships with many global wireless network solution providers, such as ZTE, Nokia Siemens Networks and Alcatel-Lucent. Our relationships with all the PRC wireless network operators, certain overseas wireless network operators and many global wireless solution providers allow us to build multiple revenue sources and capture the growth opportunities in the wireless communication industry. We design, develop and manufacture RF devices for multiple frequency or network systems (including wireless access systems, such as WiFi and PHS), GSM, CDMA, TD-SCDMA, W-CDMA and CDMA2000 protocols. For ZTE and Nokia Siemens Networks, we have been one of their suppliers of GSM and W-CDMA products in China and overseas since 2002 and 2005, respectively. ZTE is also leveraging our expertise in the design and manufacturing of RF products for TD-SCDMA and CDMA2000 networks to further enhance the 3G wireless technology and networks in China and overseas markets. We were recognized by Nokia in its Kylin Award in 2005 and 2007 and by Datang Telecom, a company engaging in business of microelectronics, software communication access, as the highest quality provider for 2008. We also have a history of selling 2G (GSM and CDMA) wireless network infrastructure to China Mobile, China Unicom and Reliance, a telecom services provider in India, and PHS wireless infrastructure to China Telecom. We began to sell 3G related products in 2004 and began to sell TD-SCDMA, W-CDMA and CDMA2000 products to China Mobile, China Unicom and China Telecom, respectively, soon after they obtained their 3G licenses on January 7, 2009.

#### **Strong research and development capability**

Our focus on RF antennas, equipment and technology and the experience we have gained through the implementation of our products in wireless communication network infrastructures around the world has enabled us to develop substantial expertise in wireless infrastructure equipment technology. Our efforts target the research and development of new products in each of our product groups. For example, we have developed new products to support a number of 3G transmission protocols, including China's new 3G protocol, TD-SCDMA, and other emerging network technologies, such as WiMax. Our comprehensive experience in the design, development and manufacturing of RF products for different segments of the wireless infrastructure, including the microwave transmission and base station RF subsystems, also provides us with technical know how that facilitates the compatibility of our RF products with our customers' requirements. Technical cooperation with global wireless network solution providers that provide us with exposure to technical developments in other regions of the world also enhances our product development capabilities. Further, this knowledge enables us to shorten our product development cycle. As a result, we are generally able to complete the design and development of a new product within a short timeframe that has been mutually agreed by our customers. This short product development cycle, which may vary from a few days for simple modification of an existing product to several months for certain specially designed products, also results from the low turnover rate among our engineers, and the shared research and development experience and know how that we continue to develop and refine. In 2006, 2007, 2008, and the eight months ended August 31, 2009, the turnover rates of our research and development engineers were 9.2%, 8.8%, 6.4% and 6.3%, respectively, calculated as the number of our research and development engineers departed during the period divided by the number of our research and development

---

## BUSINESS

---

engineers departed during the period together with the total number of research and development engineers at the end of the period. In order to promote the business and the development of advanced technology, we strengthened our research and development capacity by setting up an additional research and development center in Xian in May 2008 and recruited more qualified engineers. The number of the research and development engineers increased significantly from 89 in December 31, 2006 to 163 in August 31, 2009 with 134 engineers being holders of bachelor's degree or senior engineer certificate. Our research and development efforts also target ways to increase the manufacturing efficiency of our existing products, reduce the cost to our customers, and increase our profitability. We have been a member of the TD Industry Association that shapes the development of TD-SCDMA protocol since June 2007.

### **Comprehensive product portfolio for the RF path**

We have the ability to provide total customer solutions, including virtually all components of the RF path of a wireless network, through our product offerings in the antenna system, base station RF subsystem and coverage extension product groups. We believe that our diverse product range differentiates us from other China-based RF product suppliers, as other China-based suppliers tend to concentrate on a few segments of the RF path, such as the antennas, base station RF subsystem or coverage extension or a single customer group, such as the PRC domestic network operators. We are proactively building out our product roadmap while working very closely with our customers to ensure that we develop, build and release products based upon their requests or specifications. We have also developed many innovative products including wide-band antenna panels that covers multiple frequency bands and thereby offer commercially and technically attractive alternative solutions to wireless solution provider and network operator customers and remote electronic down tilt antennas that allow the network operators to change the direction of the antennas by remote electrical signals. We also believe that as international wireless solution providers increasingly outsource the design and manufacturing of RF products to suppliers like us, the knowledge we have gained from producing a comprehensive product portfolio will enable us to engage in more efficient technical discussions with our customers and help us shorten the product development cycle. Our comprehensive product portfolio also allows us to better meet the performance and cost efficiency requirements of our customers.

### **Close proximity to suppliers and customers and competitive cost structure**

We have strategically located our operations among China's production and logistics centers for wireless communication network products. As China emerges as the global center for RF products manufacturing, our close proximity to RF raw materials suppliers gives us an advantage over competitors in the Americas and Europe. As a result, we have benefited from comparatively low transportation and other logistic costs and short delivery times. We believe by locating our production facilities in China, we also benefit from priority supply relationships with local suppliers. In addition, our close proximity to China's major wireless network solution providers, such as ZTE, enables us to strengthen our relationships with them by providing them with timely and comprehensive service and focused technical and engineering support. Our proximity to some of the network solution providers and network operators in China enables us to better identify customer needs and market trends, and align our product development efforts with these needs and trends. Further, the manufacture and development of RF products for a variety of landscapes and coverage environments are highly customized and labor intensive. The radio frequency requirement of custom-designed RF products is tuned manually, as no automated equipment can reproduce the flexibility and precision of a human technician in manufacturing this highly customized equipment. As a result, our skilled yet cost effective workforce in China provides us with such a competitive strength. We have also designed production lines that efficiently combine both the automated and manual portions of our production process, and we rely on in-house production and strict control of our production process to ensure the quality of our products while minimizing component costs. This reduces the cost of our solutions compared to many competitors that outsource RF product manufacturing to third parties.

---

## BUSINESS

---

### **Capable management and engineering team**

Our management team has significant industry experience and strong client relationships, and has instilled in our Company a culture of strict financial responsibility. Certain members of our senior management have over 15 years of experience in the communications industry. After becoming our strategic shareholders in 2003, SB Asia, a private equity fund managed by SAIF Partners, has assisted us in developing our corporate governance policies, including replacing our domestic accounting firm with an independent auditor from an international accounting firm, introducing more sophisticated accounting control and reporting system, and broadening our management's perspective by appointing two non-executive Directors who are experienced in serving on the boards of listed companies. In addition, we had also engaged professional training consultants to provide training sessions to personnel and assist the development of our corporate structure. Our team of research and development engineers is highly trained academically and professionally. As of August 31, 2009, we had approximately 163 research and development engineers, of which 134 possessed bachelor's degrees or senior engineer certificates.

### **OUR STRATEGY**

We seek to increase our revenue, market share and customer base while seeking to control our working capital requirements and maintain low costs through implementing the following strategies:

#### **Maximize 3G opportunities by working closely with our key customers**

The issuance of 3G operator licenses by the PRC government on January 7, 2009 has triggered significant capital investment by the PRC wireless network operators. We, as an equipment manufacturer and solution provider that develop products that assist China's network operators in migrating to the 3G standard, expect to benefit greatly from this migration process. We have previously worked with several international network solution providers, such as ZTE and Nokia Siemens Networks, to develop products that work seamlessly in 3G networks, such as W-CDMA and CDMA2000 products. Starting from January 2009, we also began to sell 3G related products, including TD-SCDMA products, directly to all the 3G wireless network operators in China. In the overseas market, we have been selling W-CDMA products to overseas network operators since 2008. We intend to expand this market as we continue to advance our manufacturing and design know-how. We also intend to continue to invest in our development of 3G products and solutions so that together with our long standing customer relationships, strategic focus on 3G and good relationship with major 3G solution providers, we are strongly positioned to win business.

#### **Leverage our research and development platform to develop our customer base and increase our technology sophistication**

We believe our rapid research and development cycle put us in a competitive position in China. While exploiting our expertise on designing antenna, base station RF subsystem and coverage extension solution products, our engineers from different groups are also working together to develop integrated product solutions. The low turnover rate of our research and development engineers also ensures the continuity of this research and development platform and allows us to continue to fine-tune our technical know how. We have a group of customers whose needs and requirements

---

## BUSINESS

---

we understand well, including PRC domestic network operators, such as China Mobile, China Unicom, China Telecom and India's Reliance, and international wireless network solution providers, such as ZTE, Nokia Siemens Networks and Alcatel-Lucent. The breadth of knowledge we possess helps us to overcome design bottlenecks quickly and efficiently. As 3G networks are being built in China, we will be called to deliver products and solutions for immediate deployment. We believe that our familiarity with the 3G standards, the needs and requirements of the network operators and solution providers along different segments of the RF path, and comprehensive knowledge base and short product development cycle should position us as a preferred supplier to network operators and wireless network solution providers.

### **Capitalize on our low cost structure to gain market shares**

Our corporate culture emphasizes cost control and working capital management at all levels of our organization. We have strategically located our operations in Shenzhen, Jian and Xian among China's wireless equipment production and logistic centers to ensure we benefit from low transportation and production costs and priority supply relationships with local suppliers. We have also increased the automation of our manufacturing processes for higher efficiency and cost savings. We plan to implement design, development and manufacturing programs that will allow us to use more interchangeable components for different products and thereby further lower the number of different components required to manufacture our full product line. We intend to leverage our focus on the manufacturability of our product designs to help us increase our manufacturing productivity while reducing our product costs. We believe that our ability to offer a comprehensive range of products also allows us to better meet the cost efficiency requirements of our customers. We intend to continue to exercise financial discipline while pursuing revenue growth and product line expansion.

### **Further expand our customer base to other solution providers and network operators worldwide**

We plan to leverage our position as a leading supplier in China of antenna system and base station RF subsystem products to increase our market share in the coverage extension solutions market. By maintaining our focus on the quality, reliability and manufacturability of our product portfolio, we believe we can capitalize on the growth of China's communications networks. Further, we intend to continue to expand our customer base by offering a broad range of products at attractive prices to meet the diverse requirements of network operators and wireless solution providers worldwide. We believe there are significant growth opportunities in the overseas markets, particularly in emerging markets where significant investment in communication infrastructure is being driven by growth in the sophistication and size of the working populations. We seek to expand our overseas sales networks and capitalize on opportunities in these markets by leveraging our track record in China, existing relationship with both local and overseas network operators and wireless network solution providers.

### **OUR PRINCIPAL PRODUCT GROUPS**

Our technology and products are categorized into three principal groups: antenna systems, base station RF subsystems and coverage extension solutions.

---

## BUSINESS

---

The following table sets forth the revenue in each of our product groups and as a percentage of our total revenue.

	For the Year Ended December 31,						For the Eight Months Ended August 31,			
	2006		2007		2008		2008		2009	
	<i>RMB</i>	%	<i>RMB</i>	%	<i>RMB</i>	%	<i>RMB</i>	%	<i>RMB</i>	%
	<i>(unaudited)</i>									
	<i>(in thousands, except percentages)</i>									
Antenna System	186,392	51.7%	268,751	42.9%	260,543	38.8%	129,641	30.4%	276,282	43.7%
Base Station RF Subsystem	165,433	45.8%	340,940	54.4%	388,675	57.9%	285,025	66.8%	274,501	43.4%
Coverage Extension Solution	9,131	2.5%	17,115	2.7%	21,964	3.3%	11,772	2.8%	81,584	12.9%
<b>Total Revenues</b>	<u>360,956</u>	<u>100.0%</u>	<u>626,806</u>	<u>100.0%</u>	<u>671,182</u>	<u>100.0%</u>	<u>426,438</u>	<u>100.0%</u>	<u>632,367</u>	<u>100.0%</u>

### Antenna Systems

Our antenna system products principally consist of base station antennas, microwave antennas, terminal antennas, and other antennas for WiFi, WiMax, GPS and other applications.

**Base Station Antennas.** Base station antennas capture the wireless signal to and from the user's mobile handsets and the network operators' base stations. The base station antenna transmits and receives these wireless signals with a series of passive radiating elements that are tuned to the wireless operator's frequency band. We offer an extensive line of base station antennas that cover all major wireless voice communication protocols under the 2G standard, such as GSM and CDMA, and 3G standard, such as TD-SCDMA, W-CDMA and CDMA2000. Our base station antennas range in sizes from approximately one foot in length to large, omni-directional antennas in excess of ten feet in length. We have developed innovative products including wide-band antenna panels that covers multiple frequency bands and thereby offer commercially and technically attractive alternative solutions to wireless solution provider and network operator customers and remote down-tilt antennas that allow the network operators to change the direction of the antennas by remote electronic signals. Our product portfolio supports all major current 3G protocols adopted by ITU, including W-CDMA, CDMA2000 and TD-SCDMA. We believe we are one of the leading suppliers of TD-SCDMA antennas.

**Microwave Antennas.** We manufacture a full line of microwave antennas for applications in wireless and fixed-line communication infrastructure. The microwave antenna takes the RF transmission from the microwave radio, focuses the beam and reflects the signal to another microwave antenna at the opposite end of the link. Microwave transmission is often used by network operators and wireless solution providers as an alternative to fiber optic cable as it offers greater cost savings in long range network and through certain types of terrain.

**Terminal Antennas.** Terminal antennas are attached to consumer product equipment and represent the first and last RF links of a wireless communication network. Our terminal antennas are used in various wireless terminals, such as WLAN terminals.

**WiFi, WiMax and GPS.** For WiFi and WiMax antennas, we offer abundant design options, such as panel, planar array and omni-directional antennas. Our GPS antennas can cover gain ranging from 28dBi to 56dBi, and have been widely applied in various systems.

### **Base Station RF Subsystems**

Base station RF subsystem products are installed into or around the base stations of the wireless networks and are the integral components of the wireless base stations. The base station RF subsystem products that we design and manufacture include RF devices such as filters, duplexers, combiners, splitters and tower mount amplifiers. Our network solution provider customers incorporate our RF devices with the power amplifiers manufactured by third parties in the RF shelf of their proprietary base station controller cabinet.

**RF Devices.** RF devices include filters, duplexers, combiners, splitters and tower mount amplifiers. Filters are used to select intended RF signals and isolate these signals from unwanted interference and noise. Duplexers are used to allow one antenna to both transmit and receive signals. Combiners allow the combination of multiple signals from different RF components into one transmitting antenna. Splitters allow the signals received from one antenna be distributed to different RF components. Tower mounted amplifiers improve network performance by performing the filtering and amplification function as physically close as possible to the actual receiving antenna, thus eliminating additional signal deterioration and noise. The manufacture of RF devices require certain level of technical sophistication and the RF devices are generally custom-designed and manufactured to the specifications required by the wireless solution providers. For example, a large portion of the RF devices we sold to ZTE, Nokia Siemens Networks and Alcatel-Lucent were custom-made in nature. We have been certified as a supplier to some of the leading wireless solution providers in the world, such as Nokia Siemens Networks, Alcatel-Lucent and Nortel Networks. We are also a key supplier of RF devices to ZTE, a major Chinese wireless solution provider.

### **Coverage Extension Solutions**

Coverage extension solution products are used to extend and enhance the coverage of wireless networks in areas where signals are difficult to send or receive. We offer a wide array of coverage products consisting of various antennas and RF devices that extend wireless network coverage into buildings and other areas where it is difficult to get wireless reception. We distinguish ourselves from other coverage extension solution providers by our technical sophistication in antenna system and base station RF subsystem technology.

**In-Building Antennas.** Our in-building antennas cover frequency ranges from 800MHz to 2500MHz with a variety of different mounting options, such as wall mounting and ceiling mounting, which can satisfy most in-building coverage requirements.

**Aesthetic Antennas.** Our aesthetic antennas are capable of satisfying signal distribution requirements while resembling street lamps, lawn ornaments, advertising billboards and air-conditioners, which greatly reduce the visual pollution caused by ordinary antennas and towers in the residential areas.

**Electric Cables.** We also manufacture electric cables for use with our antennas system and base station RF subsystem products. The cables we manufacture do not require high degree of technical sophistication, we manufacture them principally as a cost saving measure for our customers.

---

## BUSINESS

---

### RESEARCH AND DEVELOPMENT

We believe that the successful marketing of our products depends on our research, engineering and production skills. Our development efforts focus on ways to reduce the cost and increase the manufacturing efficiency of our existing products. We also invest significant resources in the research and development of new products in each of our product groups. For example, we have set up an additional research and development center in Xian in May 2008. We had also entered into two technology development agreements with China Mobile Research Institute (中國移動通信有限公司研究院) to jointly develop certain TD-SCDMA related antenna technologies between March 2008 and March 2009. In addition, we have also developed new products to support a number of other 3G transmission protocols and other emerging network protocols, such as WiMax. As of August 31, 2009, we have two research and development centers, one in Shenzhen and one in Xian. Our total research and development staff, headed by one of our executive Directors, Wang Guoying, consisted of 269 employees of which 163 were research and development engineers and 134 possessed bachelor's degrees or senior engineer certificates. Our research and development team is headed by senior engineers with over 15 years of industry experience. The technological sophistication and innovative ideas of our research and development personnel have enable us to obtain 122 registered patents and file 38 pending patent applications in the PRC as of the Latest Practicable Date. For the years ended December 31, 2006, 2007, 2008 and the eight months ended August 31, 2009, our research and development expenditures were approximately RMB15.2 million, RMB24.9 million, RMB34.6 million and RMB21.3 million, respectively.

### PRODUCTION

We generally design, develop, manufacture and assemble the products we sell. We also utilize contract manufacturers for certain parts and materials, such as die cast and printed circuit boards.

#### Manufacturing

Our manufacturing process involves the assembly of numerous individual components and precise fine-tuning by production technicians. We base most of our current manufacturing operations in the Pearl River Delta region, which is one of China's production and logistics centers for wireless network products. We believe by locating our production facilities there, it allows us to enjoy lower production costs and priority supply relationships with local suppliers. All of our manufacturing facilities share a company-wide commitment to quality and continuous improvement. We have worked to ensure that our manufacturing processes and systems are based on the quality model developed by the International Organization for Standardization (ISO), and that identical management guidelines are used at different manufacturing facilities aiming to produce products of the highest quality. Our quality assurance teams oversee the verification and control of our manufacturing processes. We

---

## BUSINESS

---

received ISO 9001:2000 certification in 2001, which is the most widely recognized standard for quality management and ISO 14001 in 2004, which is the standard for environmental protection management. The following chart sets forth the manufacturing process of our antenna products.

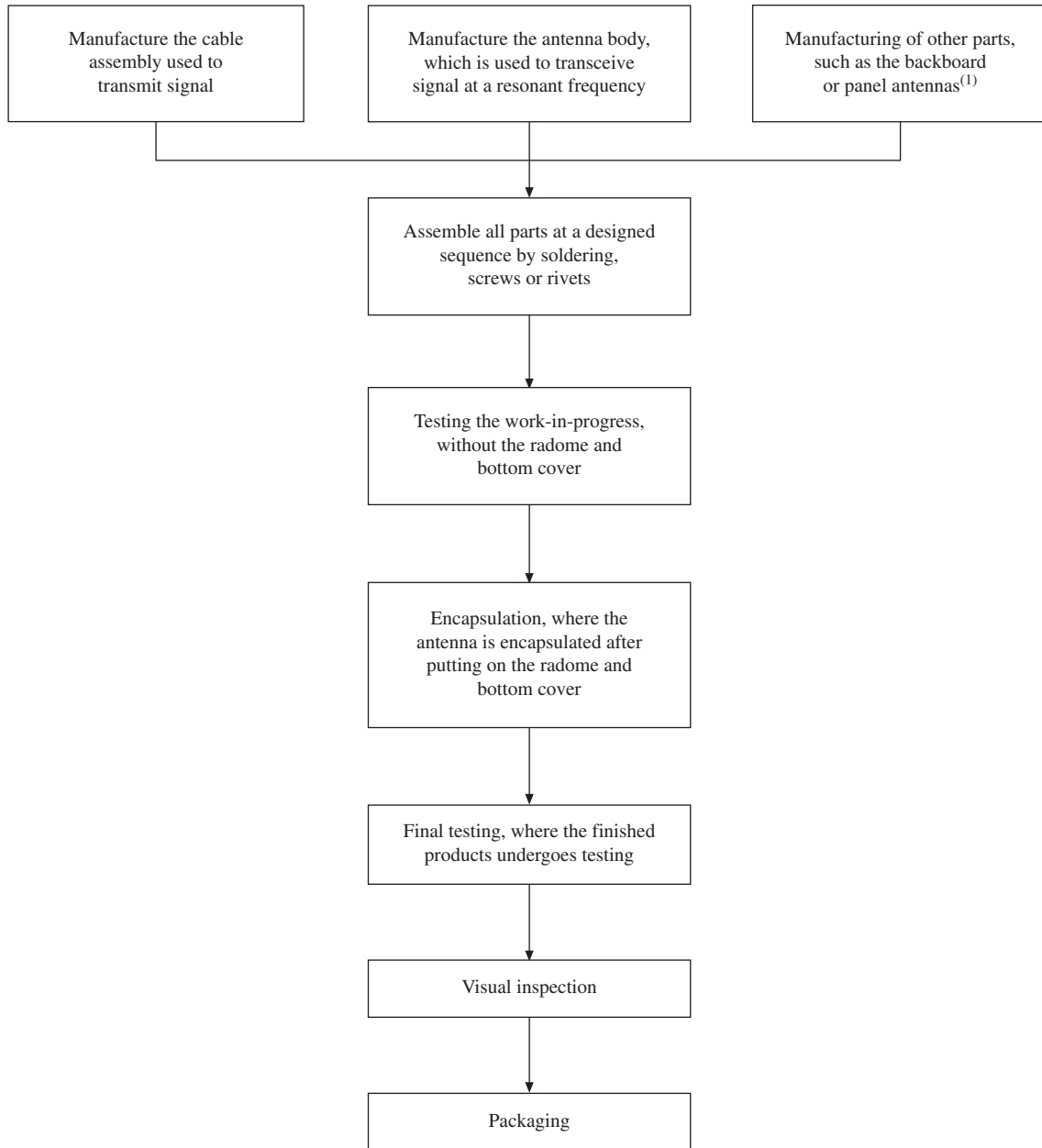

---

*Note:*

(1) These manufacturing steps may not be applicable to some types of antennas

---

## BUSINESS

---

The following chart sets forth the manufacturing process of our base station RF subsystems.

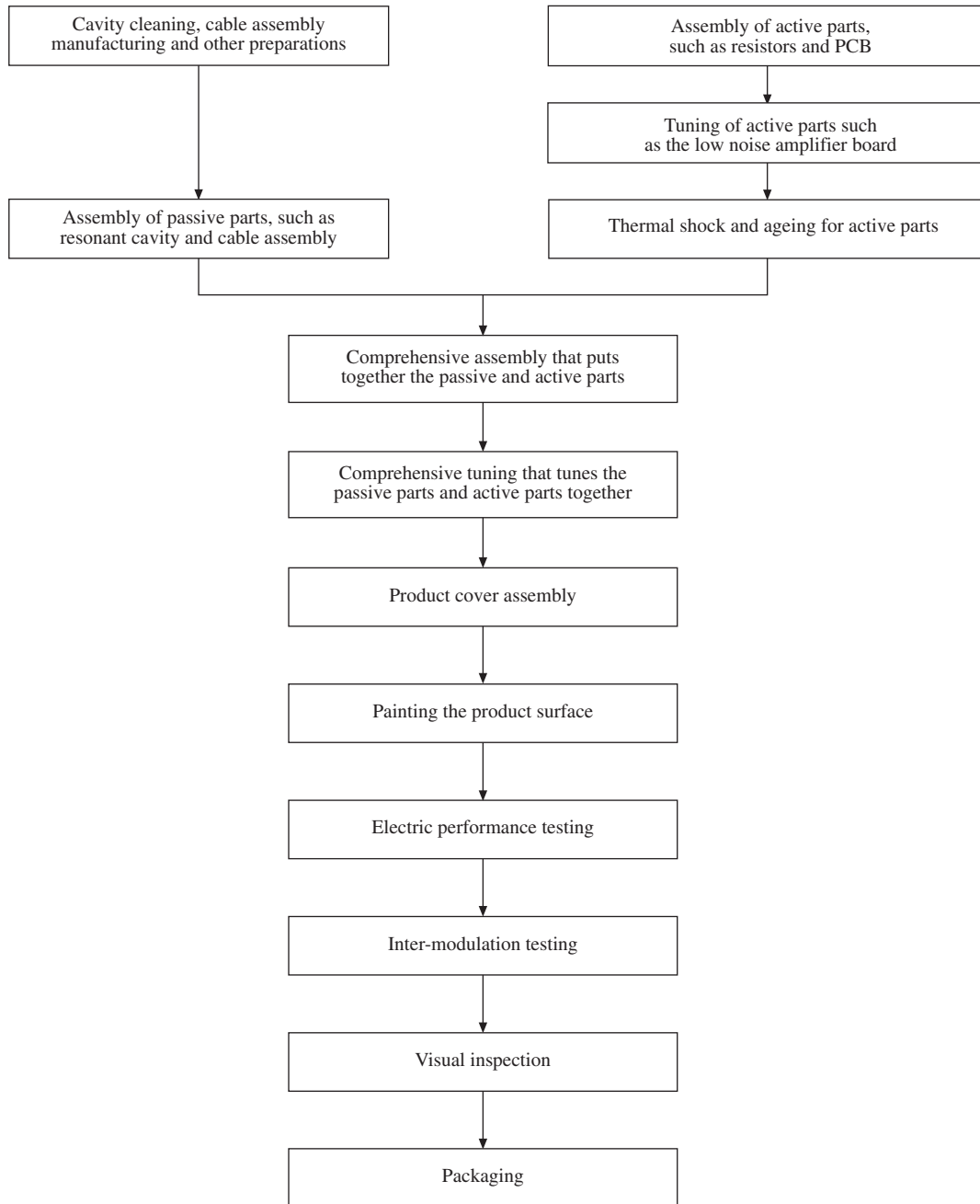

Due to the many and varied specifications of our antenna and base station RF subsystem products, we rely on the skills of our technicians in each of the design, component sourcing, assembly, tuning, testing and packaging stage to ensure the quality of our products. The raw materials we used in our manufacturing processes principally consist of (i) aluminum boards, radiators, feed networks, radomes, mounting kits, cables and connectors for our antenna products, and (ii) electric components (such as isolators, resistors and capacitors), cavities, covers, cables and connectors for our RF devices. Our research and development department designs products based on the market trends and individual requirements of our customers and produces the blue prints, specification sheets and instruction

---

## BUSINESS

---

manuals to be used in our manufacturing facilities. We manufacture some of the required components used in our products in-house to ensure the quality of our products and the steady supply of such components. From time to time, we may also assemble dedicated production lines for certain customers, staffed with engineers and technicians who are familiar with that customer's specific design features and product assembly processes. Based on our database of qualified suppliers, our component sourcing department also purchases from quality third party suppliers certain components that are casted or manufactured based on our blue prints and specification sheets to minimize component costs, in which case, we may also require our suppliers to maintain confidentiality regarding our purchases. For 2006, 2007, 2008 and the eight months ended August 31, 2009, we purchased approximately RMB295.4 million, RMB495.1 million, RMB540.8 million and RMB463.2 million of raw materials and components from third party suppliers. Due to the complexity of our products and their small dimensions, skilled technicians in our manufacturing facilities are required to assemble many sub-components together with manual precision. During our assembly process, we also subject certain components to rigorous weathering and ageing treatments as well as extreme temperature testing. Our tuning and testing process is also skills intensive. Depending on the complexity of certain products, we may tune and test individual sub-components many times prior to tuning and testing the finished products. As a result, the prices of our products can vary significantly based on the complexity of the design, high performance specifications, the quantity ordered and the manufacturing process involved.

Our sales and marketing managers review our inventory ageing list on a periodical basis for aged inventories. This involves comparison of carrying value of the aged inventory items with the respective net realizable value. The purpose of the comparison is to ascertain whether allowance is required to be made for any obsolete and slow-moving items. For the years ended December 31, 2006, 2007, 2008 and the eight months ended August 31, 2009, our inventory write-downs were approximately RMB1.1 million, RMB1,000, RMB0.4 million and RMB0.7 million, respectively.

We currently have seven manufacturing facilities, of which three are located in Shenzhen, including our manufacturing facilities located in Science and Technology Park, Chaguang Industrial Park, and Taoyuan Pingshan Minqi Industrial Park. The lease at Chaguang Industrial Park will expire on November 30, 2009 and we are currently in the process of relocating the relevant manufacturing facilities to Runheng industrial area in Shenzhen by the end of November 2009. We also have three manufacturing facilities located, respectively, in Jizhou Industrial Park, Zhongxin Industrial Park and Biliqi Industrial Park in Jiangxi Province, and one manufacturing facility located in New Type Industrial Park in Xian, Shaanxi Province. For further detail, see “— Real Property” below. Our manufacturing processes may be reconfigured for each product based on the particular product design and specifications set forth by our customers. As a result of the nature of our production processes and reliance on manual work, we are unable to quantitatively measure our production volume and utilization rate in any representative manner. We believe that the production facilities that we utilize are in good condition, well maintained, capable of ensuring the level of quality we desire and are not currently in need of any major repairs or refurbishment.

### **Quality Control**

We emphasize quality control in all aspects of our business. Our sophisticated technical skills and design experience in developing RF antennas, equipment and technology allow us to be qualified as an equipment supplier to some of the world's leading wireless network solution providers such as ZTE and Nokia Siemens Networks. We rely on in-house production and strict control of our production process to ensure the quality of our products while minimizing component costs. We have segregated the quality control functions into four departments with different specialization — reliability center, antenna quality center, RF quality center and supplier qualification. We have strengthened our quality

---

## BUSINESS

---

control capacity by recruiting more quality assurance personnel. As of August 31, 2009, we have 226 quality assurance personnel located in our Shenzhen, Jian and Xian facilities as compared with 127 in 2006. From sourcing of raw materials, production and packaging of our finished product prior to delivery, we strictly monitor and control the quality of our operations. Our quality assurance team also actively engages in product design, ensuring production considerations are addressed at an early stage of the design process and minimizing the number of products that fail our quality control tests. In order to monitor our production quality and ensure that our products meet all our internal benchmarks and customers' specifications, we have implemented various quality-control checks into our production process. We were ISO 9001:2000 certified in 2001 for our design, production and servicing process and ISO 14001 certified in 2004 for our environmental management systems at our production facility in Shenzhen. Throughout 2006, 2007, 2008 and the eight months ended August 31, 2009, we have not had any product recall or third party claim for any damage or loss sustained arising from defective products.

***Quality Control for Raw Materials and Components.*** We only purchase raw materials and components from suppliers who have passed our quality and reliability assessments and have been admitted to our list of qualified vendors. We return to suppliers any raw materials that do not pass our inspection. We also periodically assess our suppliers, and those who fail our evaluation are removed from our qualified vendor list.

***Quality Control During Production.*** We test our semi-finished products at various stages of the production process to ensure their quality and compliance with all internal benchmarks before continuing on to the next stage of the production process.

***Final Testing Before Delivery.*** After the production process is finished, we perform thorough inspections to ensure that customers' specifications are met prior to delivery of our products.

***Warranty.*** We typically provide a one to two year warranty for free repair or replacement of any defective products. Certain customers may also separately negotiate with us for longer warranty periods. Product warranty costs are recognized as expenses in the consolidated statement of comprehensive income in the period in which they are incurred. As product warranty costs had not been significant during 2006, 2007, 2008 and the eight months ended August 31, 2009, we did not make any provision for product warranties during 2006, 2007, 2008 and the eight months ended August 31, 2009. We also have not had any product recall or third party claims for any damage or loss sustained arising from defective products during 2006, 2007, 2008 and the eight months ended August 31, 2009.

### KEY CUSTOMERS

We sell most of our antenna system and base station RF subsystem products to wireless network solution providers, such as ZTE, Nokia Siemens Networks and Alcatel-Lucent, who incorporate our products into their wireless coverage solutions, such as their proprietary base stations, which they then sell to network operators worldwide. We also sell directly to PRC domestic network operators including China Mobile, China Unicom and China Telecom and to certain overseas network operators for immediate deployment into the networks they are constructing. We also sell a small portion of coverage extension solution products to other wireless solution providers whose product portfolio is more limited than ours, or who do not have the capacity to produce such products or for other reasons.

See "Our Relationship with Certain Customers and Suppliers — Our Relationship with Certain Customers" for further details regarding our relationship with ZTE.

---

## BUSINESS

---

### SALES AND MARKETING

As a supplier of RF equipment and technology for wireless communication infrastructure, our business consists of the design, manufacture, marketing and sale of RF equipment and solutions that improve coverage, range, capacity and transmission speed in 2G and 3G wireless communications networks and the microwave transmission portion of the fixed-line communication networks. We categorize our product portfolio into three principal groups: antenna systems, base station RF subsystems and coverage extension solutions. We sell our products directly to network operators in China and overseas for deployment into the networks they are constructing. We also sell our products to wireless network solution providers, such as ZTE, Nokia Siemens Networks, and Alcatel-Lucent, who incorporate our products into their wireless coverage solutions, such as their proprietary base stations, which they then sell to network operators worldwide.

The following table sets forth the revenue in each of our geographic information.

Geographic Information	For the Year Ended December 31,			For the Eight Months Ended August 31,	
	2006	2007	2008	2008	2009
PRC domestic <sup>(1)</sup>	319,252	393,271	466,320	261,178	581,072
Overseas	<u>41,704</u>	<u>233,535</u>	<u>204,862</u>	<u>165,260</u>	<u>51,295</u>
Total	<u>360,956</u>	<u>626,806</u>	<u>671,182</u>	<u>426,438</u>	<u>632,367</u>

(unaudited)

(RMB in thousands)

Note:

- (1) Includes sales made to ZTE for both PRC and overseas uses as well as China sourcing offices of international solution providers, such as Nokia Siemens Networks.

### Sales to PRC network operators

We sell our base station antennas and coverage extension solutions directly to PRC wireless communication network operators, including China Mobile, China Unicom and China Telecom. As of August 31, 2009, we had a direct sales force of more than 37 professionals covering all provinces and direct municipalities within China. Our direct sales force is also responsible for providing after sale services for our products. Our direct sales force regularly contacts our PRC network operator customers to provide information about our current product line as well as general consultation services.

The PRC domestic wireless network operators generally solicit products and services from antenna system providers by announcing a request for proposal, or RFP. The RFP cycle begins with a qualification process. Historically, product qualification is determined at the provincial level by the local affiliates of the PRC network operators. In recent years, China Unicom and China Mobile have also initiated a central procurement procedure where qualification of the suppliers for certain projects is determined by China Mobile's and China Unicom's parent company. It is anticipated that China Mobile and China Unicom intend to increase the number of projects whose requirement will be purchased through the central procurement procedure.

---

## BUSINESS

---

After receiving qualification, we generally enter into an annual framework agreement with the PRC domestic network operator customers, such as China Mobile, and then sign purchase documents with the local affiliates of the relevant PRC network operator for particular projects. Such local affiliates will oversee the installation, inspection, payment and warranty services of our products. We believe the local affiliates make their selection decision based on price, product sophistication, supplier's ability to provide warranty services, and financial viability of the supplier, and generally issue more purchase orders to stronger suppliers. Depending on the purchase order, installment payments are made upon the occurrence of contractually stipulated payment events, which typically include the delivery of our products, installation, preliminary and final inspection, or completion of the warranty period.

For China Mobile, the payment terms most commonly specified in the purchase documents signed in the eight months ended August 31, 2009 are 80% upon delivery of our products and 20% after the trial period, which usually last for about one year. For China Unicom, the payment terms most commonly specified in the purchase documents signed in the eight months ended August 31, 2009 are 70% upon delivery of our products, 20% upon the issuance of the initial inspection certificates, which usually take place within 30 to 90 days after the delivery and 10% upon the issuance of the final inspection certificates, which usually take place 180 days after the delivery. For China Telecom, the payment terms most commonly specified in the purchase documents signed in the eight months ended August 31, 2009 are 80% upon delivery of our products, with the remainder to be settled after the trial period, which usually lasts between 90 to 180 days from delivery.

Sales of our products to the PRC network operators was approximately RMB96.6 million, RMB69.8 million, RMB82.2 million and RMB258.2 million, or approximately 26.8%, 11.1%, 12.2% and 40.8% of total revenues, for 2006, 2007, 2008 and the eight months ended August 31, 2009, respectively.

### **Sales to wireless network solution providers**

We sell most of our base station antennas and base station RF subsystem products to wireless network solution providers, such as ZTE, Nokia Siemens Networks and Alcatel-Lucent, who incorporate our products into their wireless coverage solutions, such as their proprietary base stations, which they then sell to network operators worldwide.

Our marketing efforts towards wireless network solution provider customers are focused on establishing and developing long-term relationships. Our solution provider customers typically conduct lengthy and in-depth evaluations on us and our products before making purchase commitments. As of August 31, 2009, we were a qualified supplier to a number of network solution provider customers, including, but not limited to, ZTE, Nokia Siemens Networks, Alcatel-Lucent, NEC and Datang Telecom.

While we do not enter into long term contracts with our network solution provider customers, for planning purposes, these customers usually provide us with non-binding rolling forecasts that also indicate increasing or decreasing demands that form the basis of purchase orders at a later point in time. We generally invoice our solution provider customers upon delivery of our products and provide varying credit terms typically ranging from 60 to 90 days.

Sales of our products to wireless network solution provider customers including, but not limited to, ZTE, Nokia Siemens Networks and Alcatel-Lucent (but excluding sales to each of their overseas factories or inventory hubs), approximated RMB213.9 million, RMB311.4 million, RMB370.8 million and RMB316.8 million, or 59.2%, 49.7%, 55.3% and 50.2% of our total revenues, for the years ended December 31, 2006, 2007, 2008 and the eight months ended August 31, 2009, respectively.

---

## BUSINESS

---

### International Sales

Due to the increasing demand for our products by network operators and solution providers outside of China, as of the Latest Practicable Date, we have also established several international sales departments with a total of 14 personnel.

We export and sell our antenna products directly to Reliance, the second largest wireless network operator in India for deployment into its network construction projects. We also export and sell our antenna system and base station RF subsystem products directly to ITI, a network solution provider customer located in India. Our overseas sales also included sales to the overseas factories or inventory hubs of global network solution providers, such as Nokia Siemens Networks headquartered in Finland and Nortel Networks. In April 2008, we were also qualified as an approved supplier for Vodafone. However, since the recent global financial and economic crisis, one of our customers, Reliance, has significantly delayed or decreased its orders with us in 2008 and 2009 while Nortel Networks filed for protection from creditors under Chapter 11 of the United States Bankruptcy Code on January 14, 2009, both of which have resulted in a decline in our overseas sales during the period.

Since 2006, we also engage independent distributors in countries or regions where we have limited sales presence or access to local customers, such as Vietnam, Indonesia, Egypt and Mexico. Our distributors place purchase orders for their own accounts or for their affiliates' accounts, where the title of the products passes upon the delivery of the products to the distributors or the payment of the purchase price for our products, depending on the purchase order. In turn, the distributors resell such products to their local customers. Compared to our direct sales to local customers, where we would provide technical support directly to the local customers, the arrangement between us and our distributors usually requires us to provide technical training, assistance or advice to the distributors, which in turn, enable the distributors to provide technical support to their local customers. We select our distributors based on their ability to obtain purchase orders from local network operators, including their business relations with the local network operators, strength of their sales network, length of operation in the telecommunication industry and credibility. The following table sets forth our direct sales to overseas customers compared with overseas distributors during each of the periods indicated.

	For the Year Ended December 31,			For the Eight Months Ended August 31,	
	2006	2007	2008	2008	2009
				<i>(unaudited)</i>	
				<i>(RMB in thousands)</i>	
Direct sales to overseas customers	41,393	231,282	199,474	160,925	48,222
Sales to overseas distributors	<u>311</u>	<u>2,253</u>	<u>5,388</u>	<u>4,335</u>	<u>3,073</u>
Total	<u>41,704</u>	<u>233,535</u>	<u>204,862</u>	<u>165,260</u>	<u>51,295</u>

We believe quick response time and localized technical support continue to be the key to our expansion. To that end, in addition to carefully selecting the qualified local distributors with service support capabilities, we also send account managers and engineers abroad to provide hands-on support. We intend to increase the number of our service personnel available or provide further training to our local agents.

---

## BUSINESS

---

### SUPPLIERS OF RAW MATERIALS AND COMPONENTS

We purchase from third parties raw materials and components necessary to produce our products. These include electronic components, metal cases for modules, electronic cables, packaging materials and other accessories. We source most of our raw materials and components inside China except for some equipment that we import from overseas, such as the network analyzers. We procure raw materials and components from companies that have satisfied our supplier review. Our purchases are paid in Renminbi. Our suppliers generally issue invoices several weeks to two months after the delivery of the raw materials and components we ordered and we typically have credit terms of 90 days. Beginning from the second quarter of 2008, we began to negotiate with our suppliers for payment by 90-days bank acceptance notes, which further extended our payment period. As we have an extensive list of suppliers, we do not rely on any single supplier or group of suppliers to provide any of our raw materials or components. For 2006, 2007, 2008 and the eight months ended August 31, 2009, we purchased approximately RMB295.4 million, RMB495.1 million, RMB540.8 million and RMB463.2 million, respectively, worth of raw materials and components from third party suppliers. For 2006, 2007, 2008 and the eight months ended August 31, 2009, purchases from our top five suppliers together accounted for approximately 37.2%, 33.0%, 31.3% and 26.8% of our total purchases of raw materials and components, respectively, while the largest supplier accounted for approximately 22.0%, 17.8%, 10.4% and 7.9%, respectively. See “Our Relationship with Certain Customers and Suppliers — Our Relationship with Certain Suppliers” for further details regard our relationship with certain suppliers.

### COMPETITION

The wireless communications infrastructure equipment industry is extremely competitive and is characterized by rapid technological change, new product development, rapid product obsolescence, evolving industry standards and significant price erosion over the life of a product, among other factors. We aim to compete on the basis of the following key characteristics: brand, functionality, reliability, pricing, quality, design that can be efficiently manufactured in large volumes, time-to-market delivery capabilities and compliance with industry standards.

The issuance of 3G operator licenses in China on January 7, 2009 has altered the competitive landscape between antenna systems, base station RF subsystems and coverage extension solution providers as the technical expertise required by 3G networks is generally greater. In particular, the adoption of the home-grown 3G protocol, TD-SCDMA, has increased the technology gap between the PRC domestic suppliers and overseas suppliers, as the PRC domestic suppliers generally have better know how in producing related products for such home-grown technology. Notwithstanding, new competitors may enter the PRC market in response to the deployment of the TD-SCDMA networks over time. Also, competitors may form alliances and consortiums focusing on certain 3G protocols.

We have the ability to provide total customer solutions, including virtually all components of the RF path of a wireless network through our product offerings in the antenna system, base station RF subsystem and coverage extension product groups. This allows us to better meet the performance and cost efficiency requirements of our customers. We also believe that we differentiate ourselves by offering superior product quality, service and continuous technological enhancement. While we believe that few of our competitors in China can match the breadth our complete product offering, we face several strong competitors on a global level. In addition, within China, we have yet to achieve a leading position among the coverage extension solution providers, where competition is based on factors such as the availability of personnel for equipment installation and field services.

We compete with both foreign and PRC domestic companies in a rapidly consolidating market. In PRC, our principal competitors include Comba and Xian Haitian, with respect to antenna system products for PRC domestic network operator customers, Grentech and Fingu, with respect to base station RF subsystem products. We are one of the few suppliers that can offer one-stop shop for both antennas and base station RF subsystem products to both network operators and network solution providers, covering all major wireless communication standards and protocols, including GSM,

---

## BUSINESS

---

CDMA, TD-SCDMA, W-CDMA and CDMA2000. Many of our domestic competitors, such as Comba and Grentech, generate the majority of their revenues from products in the indoor and outdoor coverage solution group, such as repeaters, offered to PRC network operators. On a global level, our current competitors include CommScope/Andrew, Powerwave and Kathrein-Werke. Some of our competitors have significantly greater financial, technical, manufacturing, sales, marketing and other resources than us and have achieved greater name recognition for their existing products and technologies than we have. We cannot guarantee that we will be able to successfully increase our market penetration or our overall share of the wireless communication infrastructure equipment market in the future.

### REAL PROPERTY

As of the Latest Practicable Date, our factories, dormitories and offices have a total gross floor area of approximately 99,156.9 square meters. For details of our properties, please refer to the Property Valuation Report set out in Appendix IV to this prospectus.

#### Our owned properties

As of the Latest Practicable Date, we held the relevant long-term land use right certificates for the property interests held and occupied by us in the PRC. We have obtained the building ownership certificate for Nanshan manufacturing facility (property numbered 1 in the Property Valuation Report), our principal place of business in the PRC, which is being used for manufacturing, office, research and development purposes. As advised by our legal advisers as to PRC laws, pursuant to the Regulations of Shenzhen Special Economic Zone on Hi-Tech Industrial Park promulgated by the Standing Committee of the Shenzhen Municipal People's Congress on September 26, 2006, where an enterprise acquires land and buildings in the Hi-Tech Industrial Park in Shenzhen Special Economic Zone by means of agreement, the land use rights and building ownership rights of the properties acquired cannot be transferred or leased and cannot be pledged as security without the prior approval from the Shenzhen Land Bureau. Accordingly, as Nanshan manufacturing facility is located in the Hi-Tech Industrial Park of Shenzhen Special Economic Zone and the land use rights were acquired by entering into a supplemental agreement between MOBI Shenzhen and Shenzhen Land Bureau on June 14, 2005, the land use rights and the building ownership rights of Nanshan manufacturing facility cannot be transferred or leased and cannot be pledged as security without pre-approval from the Shenzhen Land Bureau.

With respect to our Jizhou manufacturing facility (property numbered 2 in the Property Valuation Report), the construction of this property is completed in 2009. We have obtained the building ownership certificates of this property in November 2009.

In 2009, we have established a new manufacturing facility and research and development center in Xian (property numbered 3 in the Property Valuation Report). We have obtained the building ownership certificates of this property in October 2009.

#### Our leased properties

As of the Latest Practicable Date, we leased a total of eleven properties in the PRC, five of which were for manufacturing use (namely properties numbered 4, 9, 12, 13 and 14 of the Property Valuation Report), six were used as dormitories (namely properties numbered 5, 6, 7, 8, 10 and 11 of the Property Valuation Report). We have been advised by our legal advisers as to PRC laws that (a) the respective landlords of seven of such leased properties (namely properties numbered 4, 5, 6, 7, 8, 9 and 10 of the Property Valuation Report) have not yet obtained the relevant building ownership certificates or provided construction project planning permits or other proof of ownership to our Group, (b) two of the seven leased properties that lack both building ownership certificates or other proof of ownership are used by us as factories (namely properties numbered 4 and 9 of the Property

---

## BUSINESS

---

Valuation Report) and the other five are used as dormitories (namely properties numbered 5, 6, 7, 8 and 10 of the Property Valuation Report), and (c) among the seven leased properties, five tenancy agreements with respect to properties numbered 5, 6, 7, 8 and 10 of the Property Valuation Report have not been registered or filed with the relevant housing authorities in the PRC. Accordingly, our legal advisers as to PRC laws are unable to confirm if these landlords have the lawful right to lease the relevant properties to us. Our legal advisers as to PRC laws are of the view that the lack of the relevant building ownership certificates or other proof of ownership may result in the invalidity of the respective tenancy agreements and us not being able to defend our leasehold interests against any third party who subsequently enforce their rights to the properties with the support of the PRC courts or relevant government authorities. Furthermore, as advised by our legal advisers as to PRC laws, we may be exposed to payment to the relevant PRC housing authorities of a fine not exceeding RMB294,004, which is equal to 10% of total rental amount in the event that it has been determined as our fault in causing the non-registration of the relevant lease agreements.

Our Directors consider that the absence of title certificates with respect to the relevant leased properties will not have a material adverse effect on our business. None of our dormitories or factories without building ownership certificates is crucial to our operations. The five leased properties used as dormitories did not contribute to any of our turnover or profits during 2006, 2007, 2008 and the eight months ended August 31, 2009. Although we have requested such third party landlords to either obtain the relevant ownership certificates or provide proof of ownership to us, their decision on whether to undertake these efforts is beyond our control. In the event that we need to relocate any leased premises as a result of our landlords' lack of the relevant title certificates, our Directors consider that we will be able to relocate our dormitories and factories to alternative premises without incurring significant costs and time; nor will such relocation disrupt our operations. Given the ample supply of leasehold properties for dormitory use in Shenzhen, and properties are available for lease within a similar rental range with little leasehold improvement required, we estimate the relocation of dormitories can be achieved within one week at minimal additional cost to us.

Pursuant to a deed of indemnity dated November 27, 2009, the Beneficial Owners and Fangyi Holdings, our single largest shareholder with equity interests in approximately 29.86% of our entire issued share capital after Listing, have jointly and severally given indemnities in favour of us (for ourselves and as trustee for our subsidiaries) for any claims, damages, losses, liabilities, costs (including cost of relocation), expenses, actions and proceedings incurred or suffered, or which may be incurred or suffered, by us in respect of the use of any of those leased properties of our Group in the PRC in respect of which the relevant landlords have not yet obtained the relevant building ownership certificates or provided proof of ownership to us.

### **Recent lease renewals and relocation of our manufacturing facilities**

As the lease agreement of the dormitory in Shenzhen (property numbered 10 in the Property Valuation Report) expired on August 31, 2009, we have renewed this lease agreement to August 31, 2010.

The lease agreements for properties numbered 4, 5 and 6 in the Property Valuation Report will expire on November 30, 2009. We will relocate our manufacturing facilities and dormitories in Chaguang Industrial Park (properties numbered 4, 5 and 6 in the Property Valuation Report) to Runheng properties (properties numbered 11 and 12 in the Property Valuation Report) by the end of November 2009. The lessors of Runheng properties have provided the relevant proof of ownership and the tenancy agreements have been registered.

In addition, we also plan to relocate our manufacturing facilities and dormitories in Pingshan Industrial Park (properties numbered 8 and 9 in the Property Valuation Report) to Runheng properties (properties numbered 11 and 12 in the Property Valuation Report) by the end of year 2009. The manufacturing facilities in Chaguang and Pingshan are expected to be centralized in Runheng by the end of year 2009.

---

## BUSINESS

---

In October 2009, the Runheng properties (properties numbered 11 and 12 in the Property Valuation Report) are under renovation and they will be available for relocation by November 2009. The relocation will take place in two stages. We are currently in the process of relocating the Chaguang facilities (properties numbered 4, 5 and 6 in the Property Valuation Report) whereas Pingshan facilities (properties numbered 8 and 9 in the Property Valuation Report) will be relocated in December 2009. The relocation of each of these two facilities will be completed within one week. During the relocation, the Group will adjust the production among its manufacturing facilities in Shenzhen, Jian and Xian such that there is no significant disruption of our operation. The estimated relocation costs are approximately 0.6% of the net profit of the Group for the eight months ended August 31, 2009 and the estimated renovation expenditures to be incurred with an increase of about 65.6% of gross floor area in Runheng properties as compared with the total gross floor area in Chaguang and Pingshan properties are approximately 1.0% of the net asset value of the Group as at August 31, 2009. Accordingly, we expect that the impact of such relocation on the Company's operations and financial position is minimal.

Our legal advisers as to PRC laws have advised us that based on our lease agreements for manufacturing facilities, should we desire to continue to lease our manufacturing facilities, we have a preemptive right under the relevant lease agreements to renew such leases with prior notice (notice period varies from one to three months depending on the tenancy agreements) on identical terms offered by third parties.

As of the Latest Practicable Date, our manufacturing facilities have a total gross floor area of approximately 92,460.89 square meters. The details are listed as follows:-

<b>Property number in the Property Valuation Report</b>	<b>Location</b>	<b>Gross floor area (sq.m.)</b>	<b>Nature of ownership</b>	<b>Remarks</b>
1	MOBI Building, 7 Langshan First Road, Science and Technology Park, Nanshan District, Shenzhen, Guangdong Province	16,411.98	Owned	Land use rights expire on June 19, 2050
2	Jizhou Industrial Park, Jizhou District, Jian, Jiangxi Province	8,943.60	Owned	Land use rights expire on July 25, 2056
3	6 Shuoshi Road, New Type Industrial Park, Xian, Shannxi Province	10,829.31	Owned	Land use rights expire on March 12, 2058
4	No. 15 Factory Building, Xili Chaguang Industrial Park, Shahe Road West, Nanshan District, Shenzhen, Guangdong Province	11,160.00	Leased	To be relocated to Runheng by the end of November 2009

---

## BUSINESS

---

Property number in the Property Valuation Report	Location	Gross floor area (sq.m.)	Nature of ownership	Remarks
9	Levels 1 and 2 of Block 3, Taoyuan Pingshan Minqi Industrial Park, Lishui Road, Nanshan District, Shenzhen, Guangdong Province	3,810.00	Leased	To be relocated to Runheng by the end of 2009
12	Blocks 2 and 3, Runheng Electronics Factory, Liu Xiao Er Road, Xin'an Street, Bao'an District, Shenzhen, Guangdong Province	23,900.00	Leased	Lease expires on September 24, 2014
13	Block 1, Zhongxin Industrial Park, Jian, Jiangxi Province	12,111.70	Leased	Lease expires on February 28, 2011
14	Blocks 5 to 7, Jizhou Industrial Park, Jian, Jiangxi Province	5,294.30	Leased	Lease expires on April 30, 2010

### INTELLECTUAL PROPERTY

We rely on confidentiality agreements and other protections of our technical know how to maintain our technical advantages in RF technology and solution design. We also expect to rely on patents and copyrights to protect our proprietary technologies. We have entered into confidentiality agreements with our employees. Our senior employees and employees who work in our research and development centers and other technical departments are required to sign agreements acknowledging that we own the rights to all technologies, inventions, trade secrets, works of authorship, developments and other processes generated in connection with their employment with us or their use of our resources or relating to our business or our property and that they must assign any ownership rights that they may claim in those works to us. We have also included confidentiality clauses in our sales and purchase contracts with some customers.

As of the Latest Practicable Date we have 122 registered patents and 38 pending patent applications with the Patent Office of the SIPO with respect to our RF technologies, including our antennas and RF devices. See Appendix VI — Statutory and General Information — 2. Further Information about the Business — 5. Our intellectual property rights. We have not obtained any patents outside of China. We do not anticipate any material adverse impact on our operations or financial conditions should our pending patent applications not be granted by the Patent Office of the SIPO.

We have six trademarks registered with China's Trademark Office of the SAIC and one trademark registered with Hong Kong Trademark Registry of the Intellectual Property Department of Hong Kong since 2003. As of the Latest Practicable Date, we have also filed applications for registration of four trademarks in China and one in Hong Kong. In addition, we are the registered owner of the domain names, [www.mobi-antenna.com](http://www.mobi-antenna.com) and [www.mobile-antenna.com](http://www.mobile-antenna.com). Neither website is a part of this prospectus.

---

## BUSINESS

---

Save as disclosed in the sub-section headed “Legal Proceedings” in this section, as of the Latest Practicable Date, we have not been sued for infringement of intellectual property rights by any third party. As substantially all of our business is currently conducted in China, we have not taken any action outside China to protect our intellectual property.

### INSURANCE

While we do not maintain insurance for our fixed assets, beginning in 2006, we maintain product liability insurance for certain international customers with special needs. Maintenance of product liability insurance is not compulsory under PRC laws. As of the Latest Practicable Date, we had not received any material claims from our customers regarding any of our products. During 2006, 2007, 2008 and the eight months ended August 31, 2009, we have not received any claim from third parties in relation to the use of our products.

### EMPLOYEES

As of August 31, 2009, we had a total of 2,281 full-time employees. A breakdown of our employees by function as of the same date is set forth below:

	<b>Total</b>
Management and administrative and operating support	445
Research and development	269
Manufacturing	1,443
Marketing	124
Total	<u>2,281</u>

In order to maintain quality, knowledge and skill levels of our employees, we place a strong emphasis on training. We provide training to our employees periodically, including introductory training for new employees, technical training, professional and management training, team-building and communications training.

We are also subject to various labor laws and regulations in the PRC including the PRC Labor Law (中華人民共和國勞動法), the PRC Labor Contract Law (中華人民共和國勞動合同法), the Regulation of Insurance for Labor Injury (工傷保險條例), the Unemployment Insurance Law (失業保險條例), the Provisional Insurance Measures for Maternity of Employees (企業職工生育保險試行辦法), the Interim Provisions on Registration of Social Insurance (社會保險登記管理暫行辦法), the Interim Regulation on the Levy of Social Insurance Premiums (社會保險費征繳暫行條例) and other related regulations, rules and provisions issued by the relevant governmental authorities from time to time.

According to the above mentioned laws, regulations, rules and provisions, we must enter into labor contracts if labor relationships are to be established between our employees and our PRC subsidiaries. We are also obliged to provide our employees with welfare schemes including pension insurance, medical insurance, injury insurance, unemployment insurance and maternity insurance.

MOBI Shenzhen, MOBI Jian and MOBI Xian are required to enter into labor contracts with their employees and contribute a specified percentage of the employee’s payroll costs to the social welfare scheme to fund the benefits. All contributions in relation to employee benefits have been adequately provided for during 2006, 2007, 2008 and the eight months ended August 31, 2009.

The retirement benefits scheme contributions made by us amounted to RMB1.1 million, RMB1.7 million, RMB2.5 million and RMB3.4 million for 2006, 2007 and 2008 and the eight months ended August 31, 2009, respectively.

---

## BUSINESS

---

Pre-IPO Options were granted on January 15, 2003 and August 31, 2005 to eligible persons (including our directors, officers, employees, and external consultants or advisors) under the Pre-IPO Stock Incentive Plans. Please refer to the section headed “5. Pre-IPO Options” in Appendix VI to this prospectus for further details. As of August 31, 2009, the number of Shares in respect of which Pre-IPO Options had been granted and remained outstanding was 5,124,000 (pre-Capitalization Issue) or 25,620,000 (post-Capitalization Issue).

No workers’ union is set up within our Group, but the employees have the statutory right under PRC law to join or organize workers’ unions in China. We have not experienced any significant difficulty in recruiting employees nor have we had any significant staff compensation or labor disputes during 2006, 2007, 2008 and the eight months ended August 31, 2009. We consider our relations with our employees to be good.

### ENVIRONMENTAL, HEALTH AND SAFETY MATTERS

#### Environmental Issues

Our antenna system, base station RF subsystem and coverage extension solution products are manufactured based on the designs, specifications or requirements set forth by our network operator and wireless network solution provider customers. We believe our network operator and wireless network solution provider customers, in turn, base their design and specification requirements on the laws and regulations governing the networks they are constructing. For instance, in February 2003, the European Union issued the directive on restriction on hazardous substances, or RoHS, to exercise control over the toxic and hazardous materials used in certain electronic products. We believe some of our customers changed the designs and specifications of the products they ordered from us in order to comply with the RoHS directive.

Our operations are subject to various PRC environment related laws and regulations, including the PRC Environmental Protection Law (1989), the PRC Environmental Impact Assessment Law (2003), Measures for the Control of Pollution from Electronic Information Products and Corresponding Standards (2007) and the PRC Production Safety Law (2002). We believe that our manufacturing and research and development operations are in compliance with the environmental protection laws and regulations issued by the central, provincial and local governments of the PRC. We have also obtained certain environmental management system certificates, issued by UCS, a private certification organization, certifying that our design, manufacturing, sales and service management activities on mobile communication antennas and RF devices are in conformity with ISO14001:2004 standard. The certificates are valid through October 7, 2012.

While our operation activities generate waste water and other wastes, we take steps to dispose of the wastes and by-products produced as a result of our operations in a manner that addresses environmental concerns. We have introduced an environmental manual in 2004. The manual covers, among other things, various environment-related assurance procedures, including procedures related to identification of environmental issues, compliance control, documentation, training of employees and emergencies, as well as, monitoring and mitigation.

In addition, we have implemented measures to address potential risks relating to environment and safety, such as (i) conducting trainings to enhance our employees’ awareness of environmental protection and safety issues, (ii) to the extent feasible, using environmentally friendly techniques and components, (iii) monitoring the enforcement of our environmental protection programs, and (iv) monitoring the latest development in PRC environmental protection laws and regulations on a periodic basis. In order to prevent and mitigate safety risks, we have implemented a contingency response program to cope with various emergency situations such as fire and natural disasters. The program covers organizational procedures and responses in case of emergencies, drills, safety facility inspections, accident reporting and remediation.

---

## BUSINESS

---

Our production operations are also subject to regulations and periodic monitoring by the State Environmental Protection Administration of the PRC and the relevant local government environmental protection authorities. Under the relevant PRC laws and regulations, we are required to submit an environmental impact assessment to the local environmental protection bureau for approval before undertaking construction of any new production facility or major expansion or renovation of an existing production facility. If any of our facilities is found to have engaged in activities that severely polluted or endangered the environment, the relevant authorities may impose penalties on us, as well as require us to restore the environment or remedy the effects of the pollution. Any failure to so restore or remedy within the prescribed time could result in our licenses being terminated.

We believe, and our legal advisers as to PRC laws are of the view, that we have complied with the applicable laws and regulations on environmental protection in all material respects and that, during 2006, 2007, 2008 and the eight months ended August 31, 2009, we were not in breach of such laws and regulations. As of the Latest Practicable Date, we had not been subject to any material fines or legal action involving non-compliance with any relevant environmental regulations. We are not currently aware of any threatened or pending action by any environmental regulatory authority in any of the jurisdictions in which we operate.

We spent approximately RMB27,000, RMB41,000, RMB78,000 and RMB77,000 in 2006, 2007, 2008 and the eight months ended August 31, 2009, respectively, on the implementation of environmental protection measures to ensure compliance of the applicable rules and regulations. Going forward, in the absence of significant changes to the existing environment protection rules and regulations we expect that the cost of compliance will be at a similar level as to previous years.

### **Labor and Safety Issues**

We are subject to various safety laws and regulations in the PRC including the PRC Labor Law (中華人民共和國勞動法), the PRC Labor Contract Law (中華人民共和國勞動合同法), the Fire Control Law of the PRC (中華人民共和國消防法), the Production Safety Law of the PRC (中華人民共和國安全生產法) and other related regulations, rules and provisions issued by the relevant governmental authorities from time to time.

To ensure compliance with the applicable law and regulations, our in-house legal counsel follow the updates and changes in all applicable labor and safety laws and regulations and advise our human resources and other relevant departments / committee accordingly. Our human resources department, which is responsible for the formulation and implementation of human resources policies, will from time to time make adjustment, if necessary, to our human resources policies to accommodate material changes to relevant labor and safety laws and regulations to ensure their compliance. In addition, we have established a production safety committee (the “Safety Committee”) which is responsible for production safety and labor health and safety matters. The Safety Committee is headed by the deputy general manager of production, who has over nine years experience in the field of production safety and labor health and safety. Other members of the Safety Committee include our in-house legal counsel and representatives from different departments. The Safety Committee members meet regularly to review our operations safety measures and production safety standards to ensure our production safety policies comply with the requirements of the applicable laws and regulations from time to time. We will also seek legal advice from outside counsels on labor and safety related compliance matters as and when required.

To ensure the safety of our employees, we implement operational procedures and safety standards for our production process. We provide our employees with occupational safety education and training to enhance their awareness of safety issues. We also carry out equipment maintenance on a regular basis to ensure their smooth and safety operation.

---

## BUSINESS

---

We confirm that our operations have all along been complying with the applicable labor and safety regulations in all material respects, and the required measures under the applicable law and regulations do not have a material impact on our operations and financial position.

### Health and Safety Issues

We have implemented various measures at our production facilities to promote occupational safety and to ensure compliance with applicable laws and regulations. For example, we conduct periodic inspections of our fire prevention equipment to ensure that all parts of our operations are in compliance with existing laws and regulations. As we believe that following safety practices is the best way to improve the capability of our employees to handle emergencies, we have established emergency action plans in response to fire and other emergencies.

Our operations are subject to occupational health and safety regulations set by the Ministry of Labor and Social Security and the relevant local government occupational health and safety authorities. We have established a series of safety guidelines, rules and procedures for different aspects of our production activities, including fire safety, warehouse safety, work-related injuries, electricity safety and emergency and evacuation procedures.

We confirm that our operations were in compliance with the applicable safety regulations in all material respects during 2006, 2007, 2008 and the eight months ended August 31, 2009. We believe we have established necessary measures to comply with the applicable health and safety laws and regulations. We have not encountered any safety-related accidents that had any material impact on our operations during 2006, 2007, 2008 and the eight months ended August 31, 2009. Further, as of the Latest Practicable Date, we have not received any health or safety related claims from any existing or ex-employees for any accident occurred during 2006, 2007, 2008 and the eight months ended August 31, 2009.

### LEGAL PROCEEDINGS

In December 2004, MOBI Shenzhen was alleged to have infringed a utility model patent of Guangdong Tongyu Communications Equipment Co., Ltd., (formerly known as Zhong Shan Tongyu Communications Equipment Co., Ltd.) (“Tongyu”), which utility model patent is a type of waterproof feeder structure for omni-directional antennas. Subsequently, we made an application to the Patent Review Committee to invalidate that utility model patent. Thereafter, the Patent Review Committee invalidated Tongyu’s utility model patent in part, which ruling was then upheld by The Beijing First Intermediate People’s Court and The Beijing Superior People’s Court, respectively, within their jurisdiction. On September 3, 2007, The Intermediate People’s Court of Shenzhen issued a first instance verdict in the corresponding civil proceedings dismissing the allegation of patent infringement. On September 30, 2007, an appeal against such first instance verdict was filed with The Guangdong Superior People’s Court. On June 23, 2008, The Guangdong Superior People’s Court issued a final civil judgment to affirm the first instance decision and dismissed the allegation of patent infringement. MOBI Shenzhen was found not liable for any damages. On September 15, 2009, Tongyu filed an application for retrial with The Supreme People’s Court of the PRC. On November 2, 2009, the Company received a notice dated October 16, 2009 from The Supreme People’s Court of the PRC stating that the said retrial application was accepted. We have been advised by our legal advisers as to PRC laws that after acceptance of Tongyu’s application for retrial, The Supreme People’s Court of the PRC will review the application and make a decision as to whether to retry the case within three months from the date of the acceptance of the application. If The Supreme People’s Court of the PRC decides not to retry the case on the ground for retrial presented by Tongyu, the case will be closed unless Tongyu files a new retrial application based on other grounds. Any such new application for retrial must be made within 2 years from June 23, 2008, being the effective date of the final judgment issued by The Guangdong Superior People’s Court, or where the said judgment is revoked or modified

---

## BUSINESS

---

after the said 2-year period and it is established that there had been misconduct by the personnel handling the original trial, within three months from the date Tongyu became aware of the same or should be aware of the same. If The Supreme People's Court of the PRC decides to retry the case, it may retry the case by itself or order The Guangdong Superior People's Court or other Superior People's Court to retry it. In accordance with the retrial application, Tongyu seeks to revoke the final civil judgment granted by The Guangdong Superior People's Court and to claim an aggregate amount of RMB20 million as damages for infringement. As of the Latest Practicable Date, our legal advisers as to PRC laws estimated that in the event that Tongyu succeeds in its claim against us in the retrial and if the retrial court is unable to assess the amount of profits that had been earned by the patent in dispute, we may be exposed to a maximum potential liability, if any, of approximately RMB500,000 under the PRC laws. A provision of RMB500,000 was made as at August 31, 2009.

Pursuant to a deed of indemnity dated November 27, 2009, the Beneficial Owners and Fangyi Holdings, our single largest shareholder, with equity interests in approximately 29.86% of our entire issued share capital, have jointly and severally given indemnities in favour of us (for ourselves and as trustee for our subsidiaries) for any claims, damages, losses, liabilities, expenses and proceedings incurred or suffered, or which may be incurred or suffered, by us in an aggregate amount exceeding RMB500,000 in respect of the aforesaid legal proceedings and other potential litigations.

Save as disclosed above, as at the Latest Practicable Date, there were no legal proceedings or arbitrations, pending or threatened, against us that could have a material adverse effect on our financial condition or results of operation.

---

## OUR RELATIONSHIP WITH CERTAIN CUSTOMERS AND SUPPLIERS

---

### Our Relationship with Certain Customers

#### ZTE

ZTE is a company listed on the Main Board of the Stock Exchange (stock code: 00763) and on the Shenzhen Stock Exchange (stock code: 000063). The principal business of ZTE consists of design, development, production, distribution and installation of advanced telecommunications systems and equipment, including wireless communications systems, wireline switch and access equipment, optical and data communications equipment, handsets and telecommunications software systems and services.

ZTE is one of the largest companies listed in China that provides high-technology communication equipment, including PHS, GSM, CDMA, TD-SCDMA, W-CDMA and CDMA2000 wireless protocols, with annual revenue of approximately RMB44 billion in 2008. As ZTE's demand for RF products is strong and represents a good market share, our strong commercial relationship with ZTE as a global network solution provider, has made us continuously strive to improve our technology innovation, response cycle time of our research and development, product reliability and quality control system. This is beneficial for us to get into the markets of other global network solution provider customers, such as Nokia Siemens Networks.

Shareholding structure of ZTE as of the Latest Practicable Date:

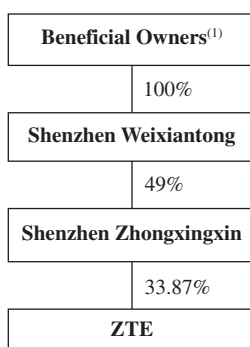

*Note:*

(1) Each of the Beneficial Owners holds the same percentage of shareholding interest in Fangyi Holdings and Shenzhen Weixiantong.

- Our non-executive Director, Qu Deqian, has been one of ZTE's five supervisors since 2005. Qu Deqian was during the period from June 2003 to January 2007 a director of Shenzhen Kanquan Electromechanical Company, a group company of ZTE, and has since March 2002 been a supervisor of Shenzhen Guoxin Electronic Development Co., Ltd., which is owned by ZTE as to 90% and by ZTE Kangxun Telecom Company, Limited as to 10%.
- Zhou Susu, the spouse of Hu Xiang, has been the senior vice president of ZTE between 1999 and 2008 and currently a director of ZTE's wholly-owned subsidiary, ZTE (H.K.) Limited.
- As of the Latest Practicable Date, the Beneficial Owners had an indirect equity interest of approximately 16.6% in ZTE through their shareholdings in Shenzhen Weixiantong. Shenzhen Weixiantong owns 49% shareholding interest in Shenzhen Zhongxingxin, which in turn had approximately 33.87% shareholding interest in ZTE as of the Latest Practicable Date.

---

## OUR RELATIONSHIP WITH CERTAIN CUSTOMERS AND SUPPLIERS

---

- Our Directors, Hu Xiang, Xing Qibin and Qu Deqian, are members of the Beneficial Owners and together held approximately 5.60% shareholding interests in Shenzhen Weixiantong as of the Latest Practicable Date. Therefore Hu Xiang, Xing Qibin and Qu Deqian have indirect shareholding interests in ZTE through their shareholding interests in Shenzhen Weixiantong.
- The direct and indirect equity interests of the Beneficial Owners in ZTE are minimal and diverse and do not render ZTE a connected person of our Group for the purpose of the Listing Rules.

We have been selected as a supplier by ZTE through its ordinary procurement procedures which include selection criteria such as price, quality, delivery time and customization services. ZTE pays by way of draft with maturity of less than 150 days after 60 days of receiving our invoice. Our Directors confirm that such sales are conducted on normal commercial terms during and after 2006, 2007, 2008 and the eight months ended August 31, 2009 and that there are no undisclosed transactions conducted between us and ZTE during 2006, 2007, 2008 and the eight months ended August 31, 2009. Except through the Beneficial Owners, none of the shareholders of ZTE are otherwise related to us or our shareholders as of the Latest Practicable Date. Except as described in the above, there is no overlapping management between us and ZTE and none of our Directors, their respective associates, or to the knowledge of our Directors, shareholders who will own more than five percent of the issued shares capital of our Company immediately following the Global Offering had any interest in any of the five largest customers of our Company during 2006, 2007, 2008 and the eight months ended August 31, 2009.

The table below sets forth the amount ZTE purchased from us in absolute terms and as a percentage of our revenue for the periods indicated. There are no other undisclosed transactions between us and ZTE during 2006, 2007, 2008 and the eight months ended August 31, 2009.

	<b>For the Year Ended December 31,</b>						<b>For the Eight Months Ended August 31,</b>	
	<b>2006</b>		<b>2007</b>		<b>2008</b>		<b>2009</b>	
	<i>RMB</i>	%	<i>RMB</i>	%	<i>RMB</i>	%	<i>RMB</i>	%
	<i>(in thousands, except percentages)</i>							
ZTE	166,757	46.2%	248,520	39.7%	237,314	35.4%	231,864	36.7%

### **Our Relationship with Certain Suppliers**

Components of RF devices such as cavity are the integral parts of RF devices and are vital to the quality of such products. As RF devices are customized to each customer, strong commercial relationships with reliable suppliers of good quality, quick response time, punctual delivery and competitive prices are beneficial to our business development. Each of Kang Cheng, Shenglongfeng and Zhongxingindi is our qualified supplier.

---

## OUR RELATIONSHIP WITH CERTAIN CUSTOMERS AND SUPPLIERS

---

### *Kang Cheng*

Shareholding Structure of Kang Cheng as of the Latest Practicable Date:

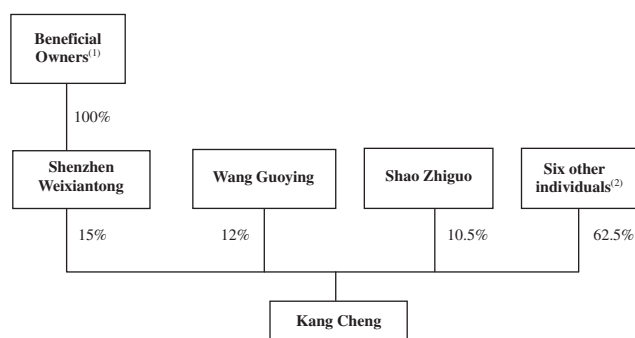

*Notes:*

- (1) Each of the Beneficial Owners holds the same percentage of shareholding interest in Fangyi Holdings and Shenzhen Weixiantong.
- (2) These individuals are not connected (within the meaning of the Listing Rules) with any Beneficial Owners, Directors, chief executive, substantial shareholders of our Company, its subsidiaries or any of their respective associates.

Kang Cheng is one of our top five suppliers during 2006, 2007, 2008 and the eight months ended August 31, 2009 and is engaged in computer numerical controlled lathe design, manufacture, sales and precision machine processing.

- Hu Xiang and Wang Guoying, our two executive Directors, and Shao Zhiguo, our vice president, made up three of the five members of the board of directors until their resignation on June 15, 2007. Hu Xiang was the legal representative of Kang Cheng until his resignation on May 16, 2007.
- During 2006, 2007, 2008 and the eight months ended August 31, 2009, Wang Guoying and Shao Zhiguo each directly maintained approximately 12.0% and 10.5% equity interest in Kang Cheng. Hu Xiang held 13% equity interest in Kang Cheng until July 16, 2007, he transferred his entire equity interest in Kang Cheng to an independent third party.
- The Beneficial Owners have an indirect equity interest in Kang Cheng through their shareholdings in Shenzhen Weixiantong. Shenzhen Weixiantong was a 15% shareholder of Kang Cheng as of the Latest Practicable Date.
- Hu Xiang, Xing Qibin and Qu Deqian, as members of the Beneficial Owners, have indirect shareholding interests in Kang Cheng through their shareholding interests in Shenzhen Weixiantong.
- The direct and indirect equity interests of the Beneficial Owners and Shao Zhiguo in Kang Cheng are minimal and diverse and do not render Kang Cheng a connected person of our Group for the purpose of Listing Rules.

---

## OUR RELATIONSHIP WITH CERTAIN CUSTOMERS AND SUPPLIERS

---

### *Shenglongfeng*

Shenglongfeng is one of our top five suppliers for the years 2007 and 2008 and is engaged in the manufacturing of connectors, including RF connectors and cable assemblies.

Shareholding structure of Shenglongfeng as of the Latest Practicable Date:

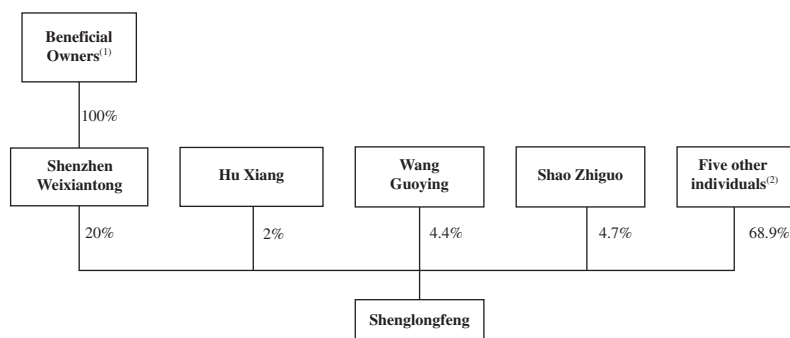

---

*Notes:*

- (1) Each of the Beneficial Owners holds the same percentage of shareholding interest in Fangyi Holdings and Shenzhen Weixiantong.
  - (2) These individuals are not connected (within the meaning of the Listing Rules) with any Beneficial Owners, Directors, chief executive, substantial shareholders of our Company, its subsidiaries or any of their respective associates.
- During 2006, 2007, 2008 and the eight months ended August 31, 2009, Hu Xiang, Wang Guoying and Shao Zhiguo have directly maintained on an individual basis approximately 2.0%, 4.4% and 4.7% equity interest in Shenglongfeng.
  - As of the Latest Practicable Date, the Beneficial Owners had an indirect equity interest of 20% in Shenglongfeng through their shareholdings in Shenzhen Weixiantong. Shenzhen Weixiantong was a 20% shareholder of Shenglongfeng as of the Latest Practicable Date.
  - Hu Xiang, Xing Qibin and Qu Deqian, as members of the Beneficial Owners, have indirect shareholding interests in Shenglongfeng through their shareholding interests in Shenzhen Weixiantong.
  - Neither our Directors nor the Beneficial Owners have any management presence in Shenglongfeng during 2006, 2007, 2008 and the eight months ended August 31, 2009 or after the Listing.
  - The direct and indirect equity interests of the Beneficial Owners in Shenglongfeng are minimal and diverse and do not render Shenglongfeng a connected person of our Group for the purpose of Listing Rules.

## OUR RELATIONSHIP WITH CERTAIN CUSTOMERS AND SUPPLIERS

### Zhongxingxindi

Zhongxingxindi is one of our top five suppliers for the year 2006 and is engaged in precision machine processing and manufacture of telecom equipment.

Shareholding structure of Zhongxingxindi as of the Latest Practicable Date:

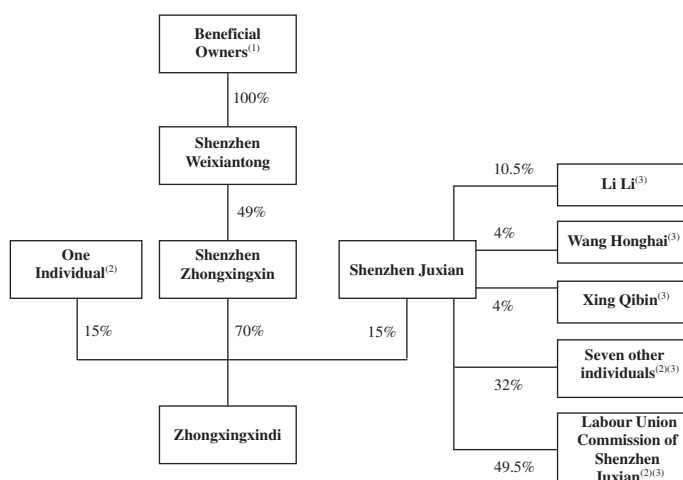

*Notes:*

- (1) Each of the Beneficial Owners holds the same percentage of shareholding interest in Fangyi Holdings and Shenzhen Weixiantong.
  - (2) These individuals/entities are not connected (within the meaning of the Listing Rules) with any Beneficial Owners, Directors, chief executive, substantial shareholders of our Company, its subsidiaries or any of their respective associates.
  - (3) These individuals/entities hold the equity interests of Shenzhen Juxian on trust for certain of ZTE's employees (excluding its directors, supervisors and senior management).
- As of the Latest Practicable Date, the Beneficial Owners had an indirect equity interest of approximately 34.30% in Zhongxingxindi through their shareholdings in Shenzhen Weixiantong. As of the Latest Practicable Date, Shenzhen Weixiantong owned 49% shareholding interest in Shenzhen Zhongxingxin, which in turn had a 70% shareholding interest in Zhongxingxindi.
  - Li Li, Wang Honghai and Xing Qibin (our non-executive Director), who are members of the Beneficial Owners, held in total approximately 18.5% equity interests in Shenzhen Juxian Investment Company (深圳市聚賢投資有限公司) ("Shenzhen Juxian") in trust for certain of ZTE's employees (excluding its directors, supervisors and senior management) as of the Latest Practicable Date. None of the Beneficial Owners are beneficiaries under the above-mentioned trust arrangement. Shenzhen Juxian was a 15% shareholder of Zhongxingxindi as of the Latest Practicable Date.
  - Our Directors, Hu Xiang, Xing Qibin and Qu Deqian, as members of the Beneficial Owners, had indirect shareholding interests in Zhongxingxindi through their shareholdings in Shenzhen Weixiantong as of the Latest Practicable Date.

---

## OUR RELATIONSHIP WITH CERTAIN CUSTOMERS AND SUPPLIERS

---

- Two of the members of the Beneficial Owners were legal representative and director, and director of Zhongxingxindi respectively during the period from the establishment of Zhongxingxindi to September 23, 2008 and May 22, 2008 respectively.
- The direct and indirect equity interests of the Beneficial Owners in Zhongxingxindi are minimal and diverse and do not render Zhongxingxindi a connected person of our Group for the purpose of Listing Rules.

During 2006, 2007, 2008 and the eight months ended August 31, 2009, the foregoing suppliers have been selected by us through our ordinary procurement procedures that include selection criteria such as price, quality and delivery time. For Kang Cheng, Shenglongfeng and Zhongxingxindi, the payment terms are 90 days following issuance of our invoices. Our Directors confirm that such purchases are conducted on normal commercial terms during 2006, 2007, 2008 and the eight months ended August 31, 2009 and will continue to do so after the Listing. Except as described above, there is no overlapping management between us and each of Kang Cheng, Shenglongfeng and Zhongxingxindi and none of our Directors, their respective associates, or to the knowledge of the Directors, shareholders who will own more than 5% of our issued share capital immediately following the Global Offering had any interests in any of our five largest suppliers during 2006, 2007, 2008 and the eight months ended August 31, 2009.

The table below sets forth the amount we purchased from Kang Cheng, Shenglongfeng and Zhongxingxindi in absolute terms and as percentage of our total purchase for the periods indicated. There are no other undisclosed transactions between us and each of Kang Cheng, Shenglongfeng and Zhongxingxindi during 2006, 2007, 2008 and the eight months ended August 31, 2009.

	For the Year Ended December 31,						For the Eight Months Ended August 31, 2009	
	2006		2007		2008		RMB	%
	RMB	%	RMB	%	RMB	%	RMB	%
	<i>(in thousands, except percentages)</i>							
Kang Cheng	64,954	22.0%	87,985	17.8%	55,987	10.4%	36,401	7.9%
Shenglongfeng	4,814	1.6%	16,478	3.3%	22,934	4.2%	8,260	1.8%
Zhongxingxindi	9,301	3.1%	16,126	3.3%	9,550	1.8%	6,145	1.3%

### CORPORATE GOVERNANCE MEASURES

The articles of our subsidiaries currently do not require purchase and supply transactions in the ordinary course of business be approved by the directors of such subsidiaries. As confirmed by our legal advisers as to PRC laws, there are no PRC laws or regulations which require that purchase and supply transactions in the ordinary course of business be approved by the board of directors of a PRC domestic company. Our management staff, which is responsible for the day-to-day operations (including the approval of purchase and supply transactions), is independent from the Beneficial Owners. Any potential conflicts of interest that may arise between our Directors or our senior management and each of ZTE, Kang Cheng, Zhongxingxindi and Shenglongfeng relate to their direct or indirect shareholding interests in the foregoing companies and the facts that Qu Deqian, our non-executive Director is ZTE's supervisor and Zhou Susu, the spouse of Hu Xiang has been the senior vice president of ZTE between 1999 and 2008, and is currently a director of one of ZTE's wholly-owned subsidiary. The foregoing interests do not affect the ability of our Directors and senior management to allocate sufficient time to manage our affairs. While Hu Xiang, Wang Guoying and Shao Zhiguo were previously directors of Kang Cheng, all of them resigned from such directorships as of June 15, 2007.

---

## OUR RELATIONSHIP WITH CERTAIN CUSTOMERS AND SUPPLIERS

---

Following the Listing and for so long as our securities are listed on the Stock Exchange, to ensure that (a) our transactions are on fair and normal commercial terms, (b) the interests of the independent shareholders will be adequately protected and (c) the conflicts of interest are avoided or adequately managed, a system of corporate governance with the following principal components will be implemented by us:

- (i) As part of our preparation for the Global Offering, we have amended our Memorandum and Articles to comply with the Listing Rules and to tighten our corporate governance. For so long as any Directors are interested in any transaction (including transactions between our Company and each of ZTE, Kang Cheng, Zhongxingxindi and Shenglongfeng (together with any company in which our controlling shareholder or its shareholders, individually or collectively, owns a direct or indirect equity interest of 10% or above, the “Relevant Companies”), a relevant board meeting attended by disinterested Directors shall be held to decide on the matter. Our Directors shall declare any interest they may have in a transaction. We will also conduct background check to ensure all interests of our Directors are fully disclosed.

The amended and restated Articles adopted by our shareholders on November 25, 2009 provide that where any Director or his/her associates has an interest in a matter, he may not vote on the resolutions of the Board approving the matter and shall not be counted towards the quorum for voting as required under the Listing Rules. Furthermore, such Director will be required to be physically absent from the relevant session of the Board meeting before the disinterested Directors discuss and decide on the matter, unless he is required to be present by resolution of the disinterested Directors. Further, even if a Director who has a conflict of interest is invited to attend the relevant session of the meetings of our board of directors for discussing and approving transactions of our Group in which he has an interest, such Director may not vote and shall not be counted towards the quorum for voting on the relevant transactions.

- (ii) Any transaction that is proposed between our Group and any of our connected persons will be required to comply with the Listing Rules.
- (iii) In addition to the requirements prescribed under the Listing Rules, we have adopted a more stringent system described below, to avoid potential conflict of interests respecting our transactions with any of our connected persons or the Relevant Companies.
  - (a) We will, without prejudice and in addition to complying with the applicable requirements set forth in the Listing Rules and other applicable laws and regulations, require that any transactions with any of our “connected persons” (as defined in the Listing Rules) be approved by way of a resolution passed by a majority of (1) our non-executive Directors and (2) the independent non-executive Directors, provided that any non-executive Director or independent non-executive Director interested in the transactions in question will declare his or her interest and will abstain from voting on such matters;
  - (b) in the event that any Director has a conflict of interest, such Director will not participate or be involved in matters relating to the relevant continuing connected transactions between us and any of our connected persons or any transaction with any of the Relevant Companies; and

---

## OUR RELATIONSHIP WITH CERTAIN CUSTOMERS AND SUPPLIERS

---

- (c) the disinterested Directors, and in particular, the independent non-executive Directors, will participate in monitoring the conduct of and operations in relation to transactions between us and any of our connected persons or any of the Relevant Companies and will not solely rely on information in relation to such transactions provided by Directors and others who are not so disinterested.
- (iv) Monitoring, review and management of any continuing connected transactions of our Group and any of our transactions with the Relevant Companies will be assigned to the Executive Committee comprising our chief financial officer (initially Chen Zhaojun) and deputy financial officer (initially Lee Wai Kuen), who will be responsible for all matters relating to these transactions under the supervision of the Supervisory Committee.
- (v) The Supervisory Committee, comprising three independent non-executive Directors (each of whom shall not have any interest in the transaction under consideration by the Supervisory Committee or be in a position of conflict of interest when acting in such capacity), has been established by our board of directors with the following primary responsibilities:
  - (a) to review and approve the terms and conditions, in particular the pricing formulae and other major commercial terms (including credit terms) as set out in any agreement governing any continuing connected transactions or transactions with the Relevant Companies from time to time entered or to be entered into by us (collectively, the “Master Agreements”) whether on a first-time basis or following expiry of the existing agreements;
  - (b) to devise and then twice a year to review detailed rules and guidelines (“Prescribed Guidelines”) for the Executive Committee to follow in order to ensure that the continuing connected transactions or transactions with the Relevant Companies will be entered into in accordance with the respective Master Agreements, on normal commercial terms and on terms that are fair and reasonable and in the interests of our shareholders as a whole;
  - (c) to review twice a year the semi-annual reports submitted by the Executive Committee in relation to the execution of transactions as to whether they have been implemented in accordance with the Master Agreements (the “Executive Committee Semi-annual Report”), which will be published on our Company’s website;
  - (d) should the Supervisory Committee consider necessary and appropriate, it may, at our cost, engage independent professional adviser(s) to assist in reviewing the terms of any of our continuing connected transactions or transactions with the Relevant Companies;
  - (e) to report its findings during its review of the Executive Committee Semi-annual Report to our board of directors and to give recommendations to the Board to ensure that transactions will be entered into in our interests and our shareholders as a whole; and
  - (f) to review on a semi-annual basis our supplier procurement bidding documents and internal procurement procedures, and to ensure that the terms therein are followed.
- (vi) Our Company shall disclose the decisions, findings and recommendations on transactions reviewed by the Executive Committee and the Supervisory Committee, including our transactions with the Relevant Companies, in our interim and annual reports.

---

## OUR RELATIONSHIP WITH CERTAIN CUSTOMERS AND SUPPLIERS

---

- (vii) Our auditors will be engaged to review our continuing connected transactions on an annual basis and report to the Supervisory Committee the result of their review. Such report shall be in compliance with the requirements in the Listing Rules.
- (viii) We shall select our suppliers pursuant to our ordinary procurement procedures that include selection criteria such as price, quality, delivery time and customization services, and shall select our suppliers based on principles of fairness and equality regardless of any interest our Director(s) or direct or indirect shareholder(s) may have in such suppliers. With respect to any tender process of our customers, we shall respond to such tender on an arm's length basis only and in particular without regard to any interest which any of our Director(s) or direct or indirect shareholder(s) may have in such customers. The Executive Committee under the supervision of the Supervisory Committee will ensure that we select our suppliers and transacts with customers in compliance with this paragraph.
- (ix) With respect to any of our supply or purchase transactions with connected persons, Relevant Companies or where any Director has a direct or indirect interest, the Executive Committee shall keep a record of the material terms of supply or purchase transactions (including without limitation price, quantity, quality and credit terms). The Executive Committee shall from time to time compare such terms with those of independent third party customers or suppliers as designated by the Supervisory Committee to ensure that all supply or purchase transactions are being conducted in the ordinary course of business and on normal commercial terms. The Executive Committee shall also obtain pricing and other related information on items of supplies or purchases with similar specifications prevailing in the market for comparison purpose.
- (x) We have appointed First Shanghai Capital as our compliance adviser, who will provide advice and guidance to us in respect of compliance with the Listing Rules and all other applicable laws, rules, codes and guidelines (including various requirements relating to directors' duties and internal control).
- (xi) We believe our independent non-executive Directors are of sufficient caliber, are free of any business or other relationship that could interfere in any material manner with the exercise of their independent judgment and able to provide an impartial, external opinion to protect the interests of our public shareholders. Background of our independent non-executive Directors are set out in the section headed "Directors and Senior Management" to this prospectus.

As part of our preparation for the Global Offering, we have amended our Memorandum and Articles to incorporate the corporate government measures described in paragraphs (i) to (ix) above. Our Directors consider that the above system of corporate governance is sufficient to avoid any potential conflict of interest in connection with our transactions and to protect the interests of our minority shareholders.

---

## DIRECTORS AND SENIOR MANAGEMENT

---

### Board of Directors

The board of directors of our Company consists of nine Directors, two of whom are executive Directors, four are non-executive Directors and three are independent non-executive Directors. Service contracts between our Company and its executive Directors, service contracts between our Company and its non-executive Directors and letters of appointment between our Company and the independent non-executive Directors (except for Li Tianshu who entered into a letter of appointment with our Company on July 1, 2007) were entered into on November 25, 2009.

### DIRECTORS

#### Executive Directors

**Hu Xiang**, aged 56, is an executive Director, the chairman of the board of Directors and the chief executive officer of our Company. He is also a director, the chief executive officer and legal representative of MOBI Shenzhen and MOBI Jian and a director of MOBI Xian. Mr. Hu was appointed a Director on December 19, 2002. Mr. Hu was an engineer. Mr. Hu graduated from the Xian Infrastructure University (now Xian University of Finance and Economics) majoring in radio communication in August 1981. During the period from 1972 to September 1981, Mr. Hu worked in the hydraulic transmission and control department of the Northwest Industrial University. Mr. Hu then served as chief of the planning and supply department at Shenzhen Zhongxingxin for the period from 1992 to 1999. Mr. Hu joined our Group in August 1999. Mr. Hu was a director of Kang Cheng from June 2002 to June 2007 and the general manager of Shenzhen Weixiantong from March 2000 to September 2007. He is one of the Beneficial Owners.

**Wang Guoying**, aged 54, is an executive Director, and also a director of MOBI Shenzhen and MOBI Jian and a director and chief executive officer of MOBI Xian. Mr. Wang was appointed a Director on December 19, 2002. He is also the Vice President in Research and Development of our Company and MOBI Shenzhen. Mr. Wang is qualified as a senior engineer. In December 1979, Mr. Wang graduated from Northwest Telecommunications Engineering College (now Xidian University) majoring in antenna engineering. Mr. Wang has held such positions as assistant engineer, engineer and senior engineer at the Shijiazhuang Communications Survey and Control Technology Institute during the period from 1987 to 1999. During this period, Mr. Wang received a second class award in PRC National Scientific Technology Advancement, a Model Individual Award for PRC National “Eighth Five-Year Plan” Scientific Technology Advancement, a second class award and a third class award respectively in Scientific Technology Advancement of the Ministry of Machine Building and Electronics Industry. Mr. Wang was a director of Kang Cheng from June 2002 to June 2007. Mr. Wang joined our Group in August 1999.

#### Non-executive Directors

**Qu Deqian**, aged 47, is a non-executive Director, and a director of MOBI Shenzhen, MOBI Jian and MOBI Xian. Mr. Qu was appointed a Director on December 19, 2002. Mr. Qu graduated from Shaanxi Institute of Finance and Economics (now School of Economics and Finance of Xian Jiaotong University) in June 1992 and he further obtained the qualification as an accountant in the PRC in October 1994. From June 1993 to April 2003, Mr. Qu was the chief of ZTE’s accounting and auditing centre and the deputy chief of its financial centre. In April 2003, Mr. Qu was appointed as the deputy general manager of Shenzhen Weixiantong and since September 2007, has been the general manager of Shenzhen Weixiantong. Mr. Qu joined our Group in December 2002. He is one of the Beneficial Owners.

**Xing Qibin**, aged 44, is a non-executive Director, and a director of MOBI Shenzhen, MOBI Jian and MOBI Xian. Mr. Xing was appointed a Director on December 19, 2002. Mr. Xing graduated from the Northwest Telecommunications Engineering College (now Xidian University) with a bachelor of

---

## DIRECTORS AND SENIOR MANAGEMENT

---

science degree in computer software in 1986. In 1989, Mr. Xing graduated from Research Institute of Post & Telecommunications as a postgraduate student. Since 2005, Mr. Xing has been the chairman and general manager of Shenzhen Jufei Optoelectronics Co., Ltd. Mr. Xing joined our Group in December 2002. He is one of the Beneficial Owners.

**Yan Andrew Y.**, aged 52, is a non-executive Director, and a director of MOBI Shenzhen, MOBI Jian and MOBI Xian. Mr. Yan was appointed a Director on January 2, 2003. He received a master's degree in arts from Princeton University in the United States in 1989. Mr. Yan was the founder of and has been the managing partner of SAIF Advisors Limited, an investment advisor to SAIF Management II Limited. Mr. Yan is currently an independent non-executive director of Fosun International Limited (stock code: 0656), Stone Group Holdings Limited (formerly known as Stone Electronic Technology Limited) (stock code: 409) and China Resources Land Limited (stock code: 1109); non-executive director of Digital China Holdings Limited (stock code: 0861) respectively, all of which are listed on the Main Board of the Stock Exchange. Mr. Yan is also a director of Acorn International Inc. (stock code: ATV), Giant Interactive Group Inc., (stock code: GA) and ATA Inc. (stock code: ATAI ) which are listed on the New York Stock Exchange, and a director of Shenzhen Eternal Asia Supply Chain Management Ltd. (stock code: 002183), which is listed on the Shenzhen Stock Exchange's Small and Medium Enterprise Board. During the period from June 2003 to February 2006, he was an independent director of Eastern Communications Co., Ltd. (stock code: 600776.SS), a company listed on the Shanghai Stock Exchange, from 2004 to September 2008, he was an independent non-executive director of China Digital TV Holding Co. Ltd. (stock code: STV) and during the period from September 2002 to June 2009, he was an independent non-executive director of China Oilfield Services Limited. (stock code: 2883), a company listed on the Main Board of the Stock Exchange. Mr Yan joined our Group in January 2003.

**Yang Dong**, aged 38, is a non-executive Director and a director of MOBI Shenzhen, MOBI Jian and MOBI Xian. Mr. Yang was appointed a Director on January 1, 2006. Mr. Yang is a charterholder of the Chartered Financial Analyst designation. Mr. Yang graduated from Tsinghua University in 1995 with a bachelor degree in computer science. In 1997, Mr. Yang obtained a master degree in accounting from the University of Southern California, United States. Mr. Yang has been working for SAIF Advisors Limited, an investment advisor to SAIF Management II Limited and is currently a partner at an affiliate of SAIF Advisors Ltd. Mr. Yang was a director of a Nasdaq listed company, Perfect World Co., Ltd. (stock code: PWRD) during the period from September 2006 to July 2008 and is currently an independent director of it. Mr. Yang joined our Group in January, 2003.

### Independent Non-executive Directors

**Li Tianshu**, aged 56, is an independent non-executive Director. Mr. Li was appointed a Director on July 1, 2007. Mr. Li graduated from Xi'an Jiaotong University in 1976 majoring in computational Mathematics. From 1985 to 1986, Mr. Li studied business economics at Universitat Mannheim in Germany and pursued a doctoral degree at Universitat Mannheim in 1988. From 1988 to 1995, Mr. Li worked as a research assistant in the business economics department of Universitat Mannheim. During the period from March 1995 to September 1995, Mr. Li worked in Germany for Friatec Aktiengesellschaft, an international manufacturing enterprise, and was designated to become the future managing director for China. From 1995 to 1998, Mr. Li first worked for KSB Aktiengesellschaft, an international machinery manufacturing enterprise, as the assistant to the chairman of the management board of KSB and then became the chief representative of its Beijing Representative Office. During the period from 1998 to 2002, Mr. Li took the position of regional director of Messer, an international chemical manufacturing enterprise, responsible for its business development in Northern China as well as the operation, sales and profits of its joint ventures and wholly owned companies in the Northern China region. During that period, Mr. Li also served as the

---

## DIRECTORS AND SENIOR MANAGEMENT

---

general manager of Messer North China Industrial Gas Co., Ltd. and the chairman to the board of Tianjin Messer Gas System Co., Ltd. Since 2002, Mr. Li has been the general manager of Beijing Delintech Technology Co., Ltd., a technical promotion service provider and sales service provider. Mr. Li has valuable experience in international corporate management and enterprise resources planning (ERP). Mr. Li joined our Group in July 2007.

**Zhang Han**, aged 45, is an independent non-executive Director appointed on November 25, 2009 and the chairman of the audit committee. Mr. Zhang is currently an independent director of Perfect World Co., Ltd. (stock code: PWRD), a Nasdaq listed company, where Mr. Zhang has also served as a member of its audit committee since July 2008. The responsibilities of such role include overseeing the accounting and financial reporting processes as well as external and internal audit of the Company. Mr. Zhang received his bachelor's degree in chemistry from the Peking University in 1985. He later obtained an EMBA degree from the China Europe International Business School in 2004. From 1985 to 1988, Mr. Zhang worked at Beijing Fiber Reinforced Plastic Research & Design Institute. Mr. Zhang was the Manager in the securities department of Shenzhen Shekou China Merchants Co., Ltd. from 1989 to 1994. Mr. Zhang was the deputy manager at the finance department of China National Technical Import & Export Corporation, and also the general manager of Shanghai CNTIC Investment Advisory Co., Ltd. from 1994 to 1998. From 1999 to 2000, Mr. Zhang served as assistant to the general manager, investment director and fund manager at Penghua Fund Management Co., Ltd., a fund management company in China. Mr. Zhang served as the deputy general manager of Rongtong Fund Management Co., Ltd., a fund management company in China, from 2001 to 2003. Mr. Zhang also served as the general manager of Great Wall Fund Management Co., Ltd., a fund management company in China, from 2004 to 2005. Mr. Zhang is currently a partner of Share Capital Partners Ltd., a Chinese venture capital firm. Mr. Zhang has built up his experience in conducting due diligence work in respect of the financial performance, management and corporate government quality of various companies and conducting financial analysis of listed companies throughout his various tenures in the investment industry. Mr. Zhang joined our Group on November 25, 2009.

**Bao Fan**, aged 39, is an independent non-executive Director appointed on November 25, 2009. Mr. Bao obtained a master's degree in Economics from Handelshøyskolen BI in 1995. Mr. Bao was the chief strategy officer of AsiaInfo Holdings, Inc., a leading IT service and software company in China, from July 2000 to March 2004. Mr. Bao is currently chief executive officer of China Renaissance Partners, an investment bank headquartered in Beijing which he founded in 2004. Mr. Bao joined our Group on November 25, 2009.

Save as disclosed, each of the Directors confirms with respect to him that: (i) he has not held any directorships in the last three years in any public companies the securities of which are listed on any securities market in Hong Kong or overseas; (ii) he does not have any relationship with any other Directors, senior management or substantial shareholders of the Company; (iii) he does not hold any positions in the Company or other members of the Group; (iv) he does not have any interests in the Shares within the meaning of Part XV of SFO; (v) there is no other information that should be disclosed for him pursuant to that requirements under Rules 13.51(2)(h) to 13.51(2)(v) of the Listing Rules; and (vi) there are not other matters that need to be brought to the attention of holders of securities of the Company.

## COMPANY SECRETARY AND SENIOR MANAGEMENT

**Lee Wai Kuen**, aged 36, is our deputy financial officer, authorized representative and company secretary. He is also the head of audit department and deputy financial officer of financial centre of MOBI Shenzhen. He is responsible for our company secretarial, financial, accounting management and internal audit affairs. Mr. Lee holds a bachelor degree in accountancy from the Hong Kong Polytechnic University. He is a Certified Public Accountant (Practising) of the Hong Kong Institute of Certified Public Accountants and a fellow member of the Association of Chartered Certified Accountants. Mr. Lee has over 10 years of experience in accounting and auditing. During the period from September 2001 to July 2003, Mr. Lee was a senior accountant of Cathay International Group.

---

## DIRECTORS AND SENIOR MANAGEMENT

---

Mr. Lee became the financial controller, qualified accountant and company secretary of TeleEye Holdings Ltd. (stock code: 8051), the finance manager, qualified accountant and company secretary of ePRO Ltd. (stock code: 8086), and the financial controller and qualified accountant of WLS Holdings Ltd. (stock code: 8021), all of which are listed on the GEM Board of the Stock Exchange, during the periods from May 2004 to June 2005, July 2005 to January 2006 and January 2006 to August 2007 respectively. Mr. Lee joined our Group on August 13, 2007.

### SENIOR MANAGEMENT

**Shao Zhiguo**, aged 46, is our vice president in Sales and Marketing, MOBI Shenzhen and MOBI Jian respectively. Mr. Shao graduated from the Northwest Telecommunications Engineering College (now Xidian University) with a bachelor degree in wireless equipment structure design in 1984. In 1998, Mr. Shao obtained a master degree in systematic engineering from Xi'an Electronic Technology University. During the period of 1984 to 1999, Mr. Shao has held such positions as engineer and senior engineer at the Shijiazhuang Communications Survey and Control Technology Institute. Mr. Shao has over 15 years experience of research and development in the area of telecommunication measurement and control technology and has received a second class award in Scientific Technology Advancement of the Ministry of Machine Building and Electronics Industry. Mr. Shao is a senior member of the Chinese Institute of Electronics. Mr. Shao was a director of Kang Cheng from June 2002 to June 2007. Mr. Shao joined our Group in August 1999.

**Huang Jianjun**, aged 47, is our deputy general manager in Antenna business of the research and development department of MOBI Shenzhen. Mr. Huang graduated from Northwest Telecommunication Engineering College (now Xidian University) in 1983 with a bachelor's degree in magnetic field engineering and specializing in antenna. Mr. Huang worked at Shijiazhuang Communications Survey and Controlling Technology Research Institute from August 1983 to April 2001, where he was awarded the qualification as an engineer in October 1992 and as a senior engineer in fixed wireless systems in 1998. Mr. Huang joined the Group in April 2001.

**Huang Youyuan**, aged 57, is our deputy general manager in RF business of the research and development department of MOBI Shenzhen. Ms. Huang graduated from Shaanxi Radio and Television University in industrial enterprises management in 1986. In 1993, Ms. Huang qualified as an accountant in 1993 and as a senior accountant in 1998. Ms. Huang had worked at China Aerospace Times Electronics Corporation during the period from December 1968 to April 2000 and her last position there was senior accountant. Ms. Huang joined the Group in March 2001.

**Liao Dong**, aged 38, is our deputy general manager in Sales and Marketing of MOBI Shenzhen. Mr. Liao graduated from Chongqing University with a doctoral degree in mechanical manufacturing and its automation in 1999. Mr. Liao had worked at ZTE Kangxun Telecom Co., Ltd. during the period from July 1999 to February 2001 and at ZTE president' office during the period from February 2001 to March 2003. Mr. Liao joined the Group in March 2003.

**Han Jianrong**, aged 49, is our deputy general manager in Production of MOBI Shenzhen, MOBI Jian and MOBI Xian. Mr. Han graduated from Northwestern Polytechnical University with a bachelor degree in foundry engineering in 1982. Mr. Han has over 20 years of experience in production. Mr. Han was appointed as an engineer at Xi'an Aerospace Engine Corporation and State-Operated Factory No. 691 of the Ministry of Aerospace Industry in 1989 and 1993 respectively, and was awarded his professional qualification as senior engineer by China Aerospace Corporation in 1997. Mr. Han joined the Group in February 2000.

---

## DIRECTORS AND SENIOR MANAGEMENT

---

**Kong Weitong**, aged 46, is our deputy general manager of Internal Operations of MOBI Shenzhen. Mr. Kong obtained a bachelor's degree in economics from Shaanxi Institute of Finance and Economics (now School of Economics and Finance of Xian Jiaotong University) in August 1998. Mr. Kong worked at the China Aerospace Corporation from 1982 to 2002 in the areas of accounting and audit, where he was appointed as an accountant in 1992 and as a senior accountant in 1999. Mr. Kong became a non-practicing member of the Chinese Institute of Certified Public Accountants in 2006. Mr. Kong joined the Group in May 2002.

**Chen Zhaojun**, aged 32, is the chief financial officer of the Company and MOBI Shenzhen, and is responsible for the financial management of MOBI Jian and MOBI Xian. Mr. Chen obtained a bachelor's degree in economics from Xiamen University in July 1999, and later obtained a master's degree in economics from Xiamen University in July 2002. Mr. Chen worked as Senior Project Manager in the Investment Department of ZTE from 2003 to 2004. Mr. Chen has been a Certified Public Accountant in the PRC since 2006. Mr. Chen joined the Group in July 2004.

### AUDIT COMMITTEE

We have established an audit committee in compliance with Rules 3.21 and 3.22 of the Listing Rules. The primary duties of the audit committee will be to review and supervise our financial reporting process and internal control system and to provide advice and comments to our board of directors. Our audit committee consists of three members who are Zhang Han, Li Tianshu and Bao Fan. Zhang Han was appointed as the chairman of our audit committee.

### REMUNERATION COMMITTEE

We have established a remuneration committee which considers and recommends to the board of directors of our Company the remuneration and other benefits paid by us to our Directors and senior management. The remuneration of all our Directors and senior management is subject to regular monitoring by the remuneration committee to ensure that levels of their remuneration and compensation are appropriate.

Our remuneration committee comprises Li Tianshu, Zhang Han, Bao Fan, Yan Andrew Y. and Qu Deqian. Li Tianshu was appointed as the chairman of our remuneration committee.

### COMPLIANCE ADVISER

Our Company has entered into a compliance adviser agreement with First Shanghai Capital to retain First Shanghai Capital as its compliance adviser pursuant to Rule 3A.19 of the Listing Rules to provide advisory services to our Company pursuant to the requirements thereunder. First Shanghai Capital will inter alia, provide advice to our Company as to compliance with the Listing Rules and all other applicable laws, rules, codes and guidelines in discharge of its duties under Chapter 3A of the Listing Rules.

The term of the appointment shall commence on the Listing Date and end on the date on which our Company complies with Rule 13.46 of the Listing Rules in respect of its financial results for the first full financial year commencing after the Listing Date.

During the term of the engagement, First Shanghai Capital shall act at all times, in addition to our two authorized representatives, as our principal channel of communication with the Stock Exchange.

---

## SHARE CAPITAL

---

### Authorized share capital:

	<i>US\$</i>
2,000,000,000 Shares	<u><u>2,000</u></u>

Assuming the Over-allotment Option is not exercised, the share capital of our Company immediately following the Global Offering will be as follows:

### Shares issued or to be issued, fully paid or credited as fully paid:

Number of Shares	Description of Shares	Aggregate nominal value of shares <i>US\$</i>	Approximate percentage of issued share capital
105,308,599	Shares in issue and upon conversion of Series A Preferred Shares as at the date of this prospectus <sup>(1)</sup>	105.31	15%
421,234,396	Shares to be issued pursuant to the Capitalization Issue <sup>(2)</sup>	421.24	60%
157,963,000	Shares to be issued under the International Placing	157.96	22.5%
17,552,000	Shares to be issued under the Hong Kong Public Offering	17.55	2.5%
<u>702,057,995</u>	Total	<u>702.06</u>	<u>100.0%</u>

Assuming the Over-allotment Option is exercised in full, the share capital of our Company immediately following the Global Offering will be as follows:

### Shares issued or to be issued, fully paid or credited as fully paid:

Number of Shares	Description of Shares	Aggregate nominal value of shares <i>US\$</i>	Approximate percentage of issued share capital
105,308,599	Shares in issue and upon conversion of Series A Preferred Shares as at the date of this prospectus <sup>(1)</sup>	105.31	14.5%
421,234,396	Shares to be issued pursuant to the Capitalization Issue <sup>(2)</sup>	421.24	57.8%
184,290,000	Shares to be issued under the International Placing <sup>(3)</sup>	184.29	25.3%
17,552,000	Shares to be issued under the Hong Kong Public Offering	17.55	2.4%
<u>728,384,995</u>	Total	<u>728.39</u>	<u>100.0%</u>

*Notes:*

(1) The 30,599,999 Series A Preferred Shares held by SB Asia will be converted into 30,599,999 Shares on the Listing Date.

---

## SHARE CAPITAL

---

- (2) Pursuant to the resolutions passed by our shareholders on November 25, 2009, the Directors were authorized to capitalize an aggregate amount of US\$421.24 standing to the credit of the share premium of our Company and to appropriate such amount as capital to pay up in full at par 421,234,396 Shares for allotment and issue to the persons whose names appear on the register of members of our Company at the close of business on November 25, in proportion to their then existing shareholdings in our Company, each ranking *pari passu* in all respects with the then existing issued Shares.
- (3) Including 26,327,000 Shares pursuant to the exercise in full of the Over-allotment Option.

According to Rule 8.08 of the Listing Rules, at the time of the Listing and at all times thereafter, we must maintain the “minimum prescribed percentage” of 25% of our issued share capital in the hands of the public.

### Assumptions

The above table assumes that the Global Offering and the Capitalization Issue have become unconditional and the issue of Shares pursuant to the Global Offering and the Capitalization Issue are made. The table takes no account of (i) any Shares which may be allotted and issued pursuant to the exercise of the Pre-IPO Options or any options which may be granted under the Share Option Scheme or (ii) any Shares which may be allotted and issued, or repurchased, as the case may be, under the general mandate or the share repurchase mandate (see below).

### Ranking

The Offer Shares will rank *pari passu* with all the Shares in issue or to be issued as mentioned in this prospectus and will rank in full for all dividends and other distributions declared, made or paid on the Shares on or after the date on which they are issued.

### GENERAL MANDATE TO ISSUE NEW SHARES

Subject to the Global Offering becoming unconditional, the Directors have been granted a general unconditional mandate to allot, issue and deal with Shares with a total nominal value of not more than the sum of:

- 20% of the total nominal amount of our issued share capital immediately following the completion of the Global Offering and the Capitalization Issue (excluding any Shares which may be issued upon the exercise of the Over-allotment Option or pursuant to the exercise of the Pre-IPO Options or any options which may be granted under the Share Option Scheme); and
- the aggregate nominal amount of our issued share capital repurchased by us (if any) pursuant to the general mandate to repurchase Shares (as referred to below).

The mandate does not apply to situations where the Directors allot, issue or deal with Shares by way of rights issue, script dividend schemes or similar arrangements providing for the allotment and issue of Shares in lieu of whole or part of a dividend in accordance with the Articles or pursuant to the exercise of any subscription or conversion rights attaching to any warrants or any securities which are convertible into Shares or in issue prior to the date of the passing of the relevant resolution or Shares issued pursuant to the exercise of any options granted under the Share Option Scheme.

The above mandate will expire:

- at the conclusion of our Company’s next annual general meeting; or
- upon the expiration of the period within which our Company is required by the Articles or any other applicable laws of the Cayman Islands to hold its next annual general meeting; or

---

## SHARE CAPITAL

---

- at the time when such mandate is revoked or varied by an ordinary resolution of the shareholders of our Company in general meeting,

whichever is the earliest.

For further details of this general mandate, see the paragraph headed “Extraordinary general meeting of our Company” in Appendix VI to this prospectus.

### REPURCHASE MANDATE

Subject to the Global Offering becoming unconditional, the Directors have been granted the repurchase mandate, which is a general mandate to repurchase Shares with a total nominal value of not more than 10% of the aggregate of the total nominal amount of the share capital of our Company in issue immediately following completion of the Global Offering and the Capitalization Issue (excluding any Shares which may be issued upon the exercise of the Over-allotment Option or pursuant to the exercise of the Pre-IPO Options or options which may be granted under the Share Option Scheme).

This general mandate only relates to repurchase made on the Main Board, or any other stock exchange on which the Shares are listed (and which is recognized by the SFC and the Stock Exchange for this purpose), and which are in accordance with the Listing Rules. A summary of the relevant Listing Rules is set out in the paragraph headed “Repurchase by our Company of its own securities” in the section headed “Further information about our Company” in Appendix VI to this prospectus.

The repurchase mandate will expire:

- at the conclusion of our next annual general meeting; or
- at the expiration of the period within which our next annual general meeting is required by the Articles or any other applicable laws of the Cayman Islands to be held; or
- at the time when such mandate is revoked or varied by an ordinary resolution of our shareholders in general meeting,

whichever is the earliest.

For further details of this repurchase mandate, see the paragraph headed “Extraordinary general meeting of our Company” in Appendix VI to this prospectus.

---

## SUBSTANTIAL SHAREHOLDERS

---

So far as the Directors are aware, immediately following completion of the Global Offering, the Capitalization Issue and conversion of the Series A Preferred Shares into Shares (without taking into account Shares that may be issued and allotted pursuant to the exercise of the Over-allotment Option or Pre-IPO Options or options which may be granted under Share Option Scheme or Shares that may be taken by a person under the Global Offering that would affect disclosure in this section), the following persons will have an interest or a short position in Shares or underlying Shares which would fall to be disclosed to our Company and the Stock Exchange under the provisions of Divisions 2 and 3 of Part XV of the SFO:

Name of Shareholder	Nature of Interest	Number of Shares <sup>(1)</sup>	Approximate percentage of shareholding
Fangyi Holdings	Beneficial owner	209,643,000(L)	29.86
SB Asia	Beneficial owner	152,999,995(L)	21.79
SB Asia Pacific Partners L.P.	Interest of a controlled corporation <sup>(2)</sup>	152,999,995(L)	21.79
Shao Zhiguo	Beneficial owner	41,496,500(L)	5.91

*Notes:*

- (1) The letter “L” denotes long position of the shareholders in the Shares.
- (2) These shares are registered in the name of SB Asia, in which SB Asia Pacific Partners L.P. is a general partner. SB Asia Pacific Partners L.P. is deemed to be interested in all the shares in which SB Asia is interested by virtue of the SFO.

Immediately following completion of the Global Offering and the Capitalization Issue; and conversion of the Series A Preferred Shares into Shares and assuming that the Over-allotment Option is not exercised, Fangyi Holdings will be our single largest shareholder with equity interests in approximately 29.86% of our entire issued share capital immediately following the Global Offering and conversion of all Outstanding Series A Preferred Shares into Shares, assuming none of the Over-allotment Option, the Pre-IPO Options, and options that may be granted under the Share Option Scheme has been exercised. For the purposes of Rule 10.07 of the Listing Rules, Fangyi Holdings, Junyi Holdings, Hou Weigui, Hu Xiang, the Beneficial Owners, Wang Guoying and Shao Zhiguo are treated as our controlling shareholders upon Listing and subject to the undertakings set forth in the subsection headed “Undertakings given to the Stock Exchange pursuant to the Listing Rules” and “Undertakings pursuant to the Hong Kong Underwriting Agreement” in the section headed “Underwriting” to this prospectus.

Fangyi Holdings is an investment holding company owned by the Beneficial Owners. For the purpose of Rule 8.10(1) of the Listing Rules, neither Fangyi Holdings nor any of the Beneficial Owners is interested in any business apart from our business which competes or is likely to compete with our business. Our Directors consider that we are capable of carrying on our business independently of Fangyi Holdings, the Beneficial Owners and any of their associates. Upon completion of the Global Offering and conversion of the Series A Preferred Shares, the Shares of our controlling shareholders do not bear different voting rights than other Shares.

Except as disclosed herein, the Directors are not aware of any person who will, immediately following the Global Offering, the Capitalization Issue and conversion of the Series A Preferred Shares into Shares (without taking into account shares which may be issued and allotted pursuant to the exercise of the Over-allotment Option or Pre-IPO Options or options which may be granted under

---

## SUBSTANTIAL SHAREHOLDERS

---

Share Option Scheme or Shares that may be taken by a person under the Global Offering which would affect disclosure in this section), have an interest or a short position in Shares or underlying Shares which would fall to our Company and the Stock Exchange under the provisions of Divisions 2 and 3 of Part XV of the SFO.

It is currently intended that pursuant to the International Underwriting Agreement, our Company will grant the Over-allotment Option to Piper Jaffray Asia Securities, the Global Coordinator and the stabilization manager, which may call upon our Company to issue up to 26,327,000 Shares to cover over-allocations in the International Placing. If the Over-allotment Option is exercised by our Company in full, the interests of the parties named in the table above in our Company's issued share capital will become:

Name of Shareholder	Nature of Interest	Number of Shares <sup>(1)</sup>	Approximate percentage of shareholding
Fangyi Holdings	Beneficial owner	209,643,000(L)	28.78
SB Asia	Beneficial owner	152,999,995(L)	21.01
SB Asia Pacific Partners L.P.	Interest of a controlled corporation <sup>(2)</sup>	152,999,995(L)	21.01
Shao Zhiguo	Beneficial owner	41,496,500(L)	5.70

---

*Notes:*

- (1) The letter "L" denotes long position of the shareholders in the Shares.
- (2) These shares are registered in the name of SB Asia, in which SB Asia Pacific Partners L.P. is a general partner. SB Asia Pacific Partners L.P. is deemed to be interested in all the shares in which SB Asia is interested by virtue of the SFO.

---

## FINANCIAL INFORMATION

---

*You should read the following discussion and analysis of our financial condition and results of operation in conjunction with our financial statements and related notes included in the Accountants' Report set out in Appendix I — "Accountants' Report" to this prospectus. The Accountants' Report has been prepared in accordance with HKFRSs. The following discussion contains forward-looking statements that involve risks and uncertainties. For additional information regarding these risks and uncertainties, please see "Risk Factors".*

### OVERVIEW

We are one of the few one-stop providers of wireless communication antennas and base station RF subsystems in China. By strategically locating our principal operations in China, we aim to capitalize on its fast growing mobile communication and equipment manufacturing industry that supplies the rapidly growing worldwide demand for mobile communication infrastructure equipment. Our business consists of the design, manufacture, marketing and sale of antennas, base station RF subsystems and solutions that are the required components of mobile communication coverage systems, including wireless access systems (WiFi and PHS), 2G (GSM and CDMA), 3G (TD-SCDMA, CDMA 2000, W-CDMA and WiMax), satellite communication and microwave transmission networks. Our product portfolio is categorized into three principal groups: antenna systems, base station RF subsystems and coverage extension solutions. We sell our products to network operators in China and overseas directly for deployment into the networks they are constructing and operating. We also sell our products to wireless network solution providers who incorporate our products into their wireless coverage solutions, such as their proprietary base stations, which they then sell to network operators worldwide.

Our sophisticated technical skills and design experience in developing antennas and base station RF subsystems enable us to be qualified as an equipment supplier to some of the world's leading wireless network solution providers, such as ZTE, Nokia Siemens Networks and Alcatel-Lucent. We also focus our marketing strategy on expanding our market share in China and certain international markets, particularly the rapidly growing emerging market countries that represent some of the greatest growth opportunities in the construction of wireless communication infrastructure, as wireless networks offer a highly cost-effective way of establishing communication infrastructure in these regions.

## FINANCIAL INFORMATION

The following table presents our selected consolidated financial information as of and for the years ended December 31, 2006, 2007, 2008 and the eight months ended August 31, 2008 and 2009.

	For the Year Ended December 31,			For the Eight Months Ended August 31,	
	2006	2007	2008	2008	2009
	<i>(unaudited)</i>				
	<i>(RMB in thousands, except per Share information)</i>				
<b>Selected Consolidated Statements of Comprehensive Income</b>					
Revenue	360,956	626,806	671,182	426,438	632,367
Cost of sales	(275,888)	(472,674)	(487,884)	(312,593)	(451,873)
Gross profit	85,068	154,132	183,298	113,845	180,494
Other income	3,741	2,943	7,103	3,647	3,610
Research and development costs	(15,171)	(24,945)	(34,550)	(21,654)	(21,305)
Distribution and selling expenses	(19,223)	(27,875)	(35,170)	(17,606)	(32,055)
Administrative expenses	(20,762)	(41,819)	(47,401)	(31,766)	(31,181)
Finance costs	(153)	(2,899)	(3,803)	(2,932)	(2,664)
Profit before taxation	33,500	59,537	69,477	43,534	96,899
Income tax expense	(2,019)	(2,764)	(7,552)	(6,186)	(12,694)
Profit and the total comprehensive income for the year/period and attributable to owners of our Company	<u>31,481</u>	<u>56,773</u>	<u>61,925</u>	<u>37,348</u>	<u>84,205</u>
Earnings per Share					
— basic <sup>(1)</sup>	<u>7.91 cents</u>	<u>15.21 cents</u>	<u>15.41 cents</u>	<u>8.83 cents</u>	<u>21.38 cents</u>
— diluted <sup>(2)</sup>	<u>5.99 cents</u>	<u>10.62 cents</u>	<u>11.60 cents</u>	<u>6.93 cents</u>	<u>15.50 cents</u>

*Notes:*

- (1) Basic earnings per Share of 7.91 RMB cents, 15.21 RMB cents, 15.41 RMB cents, 8.83 RMB cents and 21.38 RMB cents for the years ended December 31, 2006, 2007, 2008 and the eight months ended August 31, 2008 and 2009, respectively, are calculated by reference to the earnings of RMB29.5 million, RMB56.8 million, RMB57.6 million, RMB33.0 and RMB79.8 million in each of the respective periods and weighted average number of Shares of 372,500,000, 373,232,000, 373,543,000, 373,543,000 and 373,543,000 in each of the respective periods.
- (2) Diluted earnings per Share of 5.99 RMB cents, 10.62 RMB cents, 11.60 RMB cents, 6.93 RMB cents and 15.50 RMB cents for the year ended December 31, 2006, 2007, 2008 and the eight months ended August 31, 2008 and 2009, respectively, are calculated by reference to the earnings of RMB31.5 million, RMB56.8 million, RMB61.9 million, RMB37.3 million and RMB84.2 million in each of the respective periods and weighted average number of Shares of 525,445,000, 534,405,000, 533,954,000, 538,789,000 and 543,140,000 each of the respective periods.

---

## FINANCIAL INFORMATION

---

### **BASIS OF PRESENTATION**

Our Company is a limited liability company established in the Cayman Islands on December 16, 2002. Our Company is an investment holding company. The principal activities of our subsidiaries are the manufacture and sale of antennas and base station RF subsystems. Our financial information is presented in Renminbi, which is also our functional currency. Our consolidated statement of comprehensive income and the consolidated statement of cash flow for the three years ended December 31, 2008 and eight months ended August 31, 2009 present the results of operations and cash flows. Our consolidated statement of financial position as of December 31, 2006, 2007 and 2008 and August 31, 2009 present our assets and liabilities as of those dates.

### **FACTORS AFFECTING OUR RESULTS OF OPERATIONS**

Our business, financial position and results of operations are significantly affected by a number of factors, many of which may not be within our control. A discussion of the principal factors affecting our results of operations is set out below.

#### **Our business and results of operations are affected by economic cycles, including the recent global financial and economic crisis.**

Since the second half of 2008, the global financial system has experienced significant difficulties and disruptions, leading to reduced liquidity, greater volatility, widened credit spreads and a lack of price transparency in the global credit and financial markets. The difficulties in global credit and financial markets have also resulted in a widening global economic crisis. There are indications that the current financial and economic downturn may persist or worsen. The slowdown experienced in the economies of the United States, the European Union and certain Asian countries adversely affected the capital expenditures of the network providers in different countries. The resulting decrease and slowdown in demand for mobile communication infrastructure equipment has put significant downward pressure on prices of antenna and base station RF subsystem products, which are our major source of sales revenues. There can be no assurance as to when the market for our products will recover and that we will not suffer a significant further downturn.

While various governments have announced efforts to increase liquidity in the financial markets and stimulus packages to slow or reverse the economic downturn, there can be no assurance that these measures will be successful. If the global economy continues to grow at a slower rate than expected, or experiences a recession, growth in demand for the mobile communication infrastructure products will also continue to slow down or decrease. As a result, our business, financial condition and results of operations would continue to be adversely affected. Our business model is very sensitive to the spending cycle of the communication network providers, and without a recovery in consumer usage, downward pressure on prices and demand for our products will persist.

#### **Development of telecommunications services industries in China and overseas**

Demand for our products depends primarily on the amount of capital spending by network operators in China and overseas. We sell our products to network operators either directly or through wireless network solution providers, such as ZTE, Nokia Siemens Networks and Alcatel-Lucent, who incorporate our products into the wireless network solutions they sell to network operators. Our future success depends upon the growth in demand for wireless communication services.

---

## FINANCIAL INFORMATION

---

Further, capital spending by network operators in China, our largest market, can be influenced by a variety of factors, including the evolution of the Chinese communication network standards and protocols, the intensity of competition among the equipment suppliers and the international stock exchange listings of some of the network operators, which could result, among other things, in greater access to capital for infrastructure building or an increased focus on controlling costs in order to increase returns for investors.

These factors can cause our operating results to fluctuate from period to period. For instance, we believe that throughout 2006, 2007 and most of 2008, PRC domestic network operators delayed or decreased their capital spending in China in anticipation of the issuance of the 3G licenses and that the subsequent build out of 3G networks which would be capital intensive. Such reduced spending on wireless networks had a negative effect on domestic sales for 2006, 2007 and most of 2008. If network operators delay or reduce their levels of capital spending, our operating results would be negatively affected. Similarly, an economic downturn could also lead to a softening in demand for our products and services, which could result in a decrease in our revenues and earnings. Accordingly, changes in the businesses, infrastructure and capital spending plans of the network operators have a direct effect on our results of operations.

### **Introduction of 3G standards and different transmission protocols**

The wireless network infrastructure market is characterized by evolving industry standards and transmission protocols. We sell products that support a number of 3G transmission protocols, including TD-SCDMA, W-CDMA2000 and CDMA2000, the protocols adopted by China Mobile, China Unicom and China Telecom, respectively, on January 7, 2009, to global wireless network solution providers such as ZTE, Nokia Siemens Networks and Alcatel-Lucent. We expect the PRC network operators to continue their high level of capital spending to complete the deployment of 3G networks throughout 2009 and beyond. However, if the PRC consumers fail to adopt to 3G services or the network operators decide to decrease the rate of 3G network build out, or not to build out at all, we may not be able to realize returns on our research and development expenditure on 3G related products or we may experience lower gross profit margin if our sales constitute primarily of 2G products.

### **Competitive market**

We are in an extremely competitive industry, which is characterized by rapid technological advancement, downward pricing trends over the life cycle of a solution and high working capital requirements. We primarily compete on the following bases:

- design capability for wireless network infrastructure;
- quality of RF products;
- implementation capability;
- after-sales services;
- pricing and payment terms; and
- relationships with network operators.

There can be no assurance that we will maintain our competitiveness in these areas. If we fail to develop new products and services, periodically enhance our existing products and services, or otherwise compete successfully, it would reduce our sales and adversely affect our future prospects.

---

## FINANCIAL INFORMATION

---

### **Limited number of customers**

Most of our sales are made to a small number of key customers. For example, our largest customer, ZTE, accounted for approximately 46.2%, 39.7%, 35.4%, and 36.7% of our sales for the years ended December 31, 2006, 2007, 2008 and the eight months ended August 31, 2009. We expect that this will continue. Sales to our top five customers for the years ended December 31, 2006, 2007, 2008 and the eight months ended August 31, 2009, accounted for approximately 87.2%, 90.2%, 85.8% and 91.4% of our total revenues, respectively. Our future success is dependent upon the continued purchases of our products by a small number of customers, and any fluctuations in demand from such customers or other customers would negatively affect our results of operations. If we are unable to broaden our customer base and expand relationships with major network solution providers and operators, our business may continue to be affected by unanticipated demand fluctuations due to our dependence on a small number of customers. Unanticipated demand fluctuations can have a negative effect on our revenues and business, and an adverse effect on our results of operations and financial condition. In addition, our dependence on a small number of major customers exposes us to numerous other risks, including:

- a slowdown or delay in deployment of wireless networks by any one customer could significantly reduce demand for our products;
- reductions in a single customer's forecasts and demand could result in excess inventories;
- consolidation of customers can increase pricing pressure on our products due to increased purchasing leverage;
- each of our customers has significant bargaining leverage over us to require changes in sales terms including pricing, payment terms and product delivery schedules;
- a customer could compete with us directly should it decide to increase its level of internal designing and/or manufacturing of wireless communication network products; and
- we may face significant credit risk as a result of the significant concentration of accounts receivable, which could have a material adverse effect on our liquidity and financial condition if one of our major customers declared bankruptcy or delayed payment of our accounts receivables.

We expect to continue to depend upon a relatively limited number of customers for a significant portion of our revenue. Our ability to maintain close relationships with our customers is therefore essential to the ongoing growth and profitability of our business.

### **Declining selling prices**

Wireless network operators are continuing to place pricing pressure on wireless infrastructure builders, including wireless network solution providers and coverage extension solution providers, which in turn, has resulted in lower selling prices for our products over time, with certain competitors aggressively reducing prices in an effort to increase their market share. Our industry is also characterized by evolving industry standards and transmission protocols. For instance, the PHS network infrastructure may gradually be phased out by China Unicom and China Telecom as they prepare to migrate their subscribers to 3G standards. While we expect the pricing for most of our 3G related products to be higher than our current 2G related products, the introduction of 3G standards in China may also attract new competitors to the wireless network infrastructure market due to the expected higher pricing.

---

## FINANCIAL INFORMATION

---

### SEGMENT INFORMATION

The Group's reportable segments are as follows:

Antenna system	manufacture and sale of antenna system and related products.
Base station RF subsystem	manufacture and sale of base station RF subsystem and related products.
Coverage extension solution	manufacture and sale of a wide array of coverage products.

### GEOGRAPHICAL INFORMATION

We divide our provision of sales and services geographically to PRC domestic sales and services, which forms our geographic information, and overseas sales and services, which mainly consist of our sales to customers in Europe and India. In 2006, 2007, 2008 and the eight months ended August 31, 2009, our overseas sales accounted for approximately 11.6%, 37.3%, 30.5% and 8.1% of our revenues, respectively.

### CRITICAL ACCOUNTING POLICIES

#### *Revenue recognition*

Our revenue is measured at the fair value of the consideration received or receivable and represents amounts receivable for goods sold in the normal course of business, net of discounts and related sales taxes.

Our sales of goods are recognized when goods are delivered and title has passed.

Our interest income from a financial asset is accrued on a time basis, by reference to the principal outstanding and at the effective interest applicable, which is the rate that exactly discounts the estimated future cash receipts through the expected life of the financial asset to that asset's net carrying amount.

#### *Property, plant and equipment*

Our property, plant and equipment other than construction-in-progress are stated at cost less accumulated depreciation and any accumulated impairment losses. Construction-in-progress is stated at cost which includes all construction costs and other direct costs attributable to such projects.

Our construction-in-progress is not depreciated until completion of construction and the asset is available for use. The cost of completed construction works is transferred to the appropriate category of property, plant and equipment.

Our depreciation is provided to write off the cost of items of property, plant and equipment, other than construction-in-progress, over their estimated useful lives and after taking into account of their estimated residual values, using the straight-line method, at the following rates per annum:

Buildings	Over the shorter of the term of lease or 50 years
Furniture, fixtures and equipment	19%
Leasehold improvements	50%
Motor vehicles	19%
Plant and machinery	9.5% - 19%

---

## FINANCIAL INFORMATION

---

An item of property, plant and equipment is derecognized upon disposal or when no future economic benefit is expected to arise from the continue use of the asset. Any gain or loss arising on derecognizing of the asset (calculated as the difference between the net disposal proceeds and the carrying amount of the item) is included in the consolidated statements of comprehensive income in the period in which the item is derecognized.

### *Inventories*

Inventories are stated at the lower of cost and net realizable value. Cost is calculated using the weighted average method.

### *Loans and receivables*

Loans and receivables are financial assets with fixed or determinable payments that are not quoted in an active market. Loans and receivables are measured at amortized cost using the effective interest method less impairment. The amount of impairment is the difference between the asset's carrying amount and the present value of estimated future cash flows, discounted at the original effective interest rate. Impairment losses are reversed in subsequent periods when an increase in the asset's recoverable amount can be related objectively to an event occurring after the impairment was recognized, subject to a restriction that the carrying amount of the asset at the date the impairment is reversed does not exceed what the amortized cost would have been had the impairment not been recognized.

### *Share-based Payment Transactions*

We have granted options on January 15, 2003 ("2003 Option") and August 31, 2005 ("2005 Option") for the primary purpose of providing incentives to directors and eligible employees, and they will expire on January 15, 2013 and August 31, 2015, respectively. Under the Pre-IPO Stock Incentive Plan, our board of directors could grant options to eligible employees, including directors of our Company and its subsidiaries, to subscribe for shares in our Company. Additionally, we may, from time to time, grant share options to an individual consultant or advisor who renders or has rendered bona fide services to us.

On August 31, 2009, the number of shares prior to the Capitalization Issue in respect of which options had been granted and remained outstanding under the 2003 Option and 2005 Option was 5,124,000 (December 31, 2006: 5,332,500, December 31, 2007: 5,332,500, December 31, 2008: 5,265,500), representing 4.87% (December 31, 2006: 5.33%, December 31, 2007: 5.06%, December 31, 2008: 5.00%) of our shares in issue at that date. As of the Latest Practicable Date, the maximum number of ordinary shares prior to the Capitalization Issue that may be delivered pursuant to awards granted to eligible persons under 2003 Option and 2005 Option is equal to 2,750,000 and 2,361,500 ordinary shares respectively.

No consideration is payable on the grant of an option. Options may be exercised at any time from 12 months from the date of grant of the share option to the tenth anniversary of the date of grant.

---

## FINANCIAL INFORMATION

---

Details of specific categories of options are as follows:

Option type	Date of grant	Vesting period	Exercise period	Exercise price (pre-Capitalization Issue)	Fair value at grant date
2003 Option	January 15, 2003	January 15, 2003 to January 14, 2007	January 15, 2004 to January 14, 2013	RMB1.76	RMB0.95
2005 Option	August 31, 2005	August 31, 2005 to August 30, 2009	August 31, 2006 to August 30, 2015	RMB3.66	RMB1.36

The fair value of services received determined by reference to the fair value of share options granted at the grant date is expensed on a straight-line basis over the vesting period, with a corresponding increase in equity (share option reserve). At the end of each reporting period, we revise our estimates of the number of options that are expected to ultimately vest. The effect of the revision of the estimates, if any, is recognized in profit or loss, with a corresponding adjustment to share option reserve.

Assuming that all the outstanding options granted under the Pre-IPO Stock Incentive Plans were exercised in full on the Listing Date, the then original shareholding interest of the public would be reduced from approximately 31.6% to approximately 30.5% of the total issued share capital of our Company immediately after completion of the Global Offering, taking no account of any Shares that may be issued pursuant to the exercise of the Over-allotment Option, any Shares that may be allotted and issued pursuant to the exercise of any options granted under the Share Option Scheme or any Shares that may be issued by our Company pursuant to the general mandate as described under the paragraph headed “Extraordinary general meeting of our Company” in Appendix VI — Statutory and General Information. Our Directors and the senior management of our Company will not exercise any Pre-IPO Options if, as a result of such exercise, our Company will not be able to comply with the public float requirements of the Listing Rules.

Our shareholding immediately following the Global Offering, assuming the Over-allotment Option is not exercised, would be diluted by approximately 3.5% upon the exercise of the Pre-IPO Options. Assuming that (i) the Global Offering had occurred on January 1, 2009; (ii) a total of 702,057,995 Shares had been in issue during the year; (iii) all the Pre-IPO Options were exercised in full on January 1, 2009; and (iv) taking no account of any Shares that may be issued pursuant to the exercise of the Over-allotment Option, any Shares that may be allotted and issued pursuant to the exercise of any options granted under the Share Option Scheme or any Shares that may be issued by our Company pursuant to the general mandate as described under the paragraph headed “Extraordinary general meeting of our Company” in Appendix VI — Statutory and General Information, the exercise of the Pre-IPO Options will have diluted the unaudited pro forma forecast basic earnings per Share for the year ending December 31, 2009 from RMB0.1449 to RMB0.1398. Except as disclosed above, no further options will be granted under the Pre-IPO Stock Incentive Plans after the date of this prospectus. We engaged an international valuation consultancy to make an appraisal of the fair market value of the Pre-IPO Options granted on January 15, 2003 and August 31, 2005 of RMB0.95 and RMB1.36, respectively, as at the grant date, which represent a discount of approximately 60.2% and 43.0%, respectively, to the minimum Offer Price of HK\$2.72 and a discount of approximately 69.1% and 55.7%, respectively, to the maximum Offer Price of HK\$3.50, based on an exchange rate of RMB1.00 converted to HK\$1.14 and without taking into account the Capitalization Issue.

---

## FINANCIAL INFORMATION

---

### *Allowance for bad and doubtful debts*

Ongoing credit evaluations of customers is performed and credit limits would be adjusted based on payment history and the customer's current credit-worthiness, as determined by the review of their current credit information. Allowance for bad and doubtful debts is maintained for estimated credit losses. The amount of allowance is measured as the difference between the asset's carrying amount and the present value of estimated future cash flows (excluding future credit losses that have not been incurred) discounted at the financial asset's original effective interest rate (i.e. the effective interest rate computed at initial recognition) based upon its historical experience and any specific customer collection issues that has been identified. Reversal of allowance for bad and doubtful debts was made when the recoverable amount of those debts on which allowance had previously been made is estimated to be greater than its carrying amount. For the years ended December 31, 2006, 2007, 2008 and the eight months ended August 31, 2009, allowance for (reversals of allowance for) bad and doubtful debts (included in administrative expenses) were approximately RMB(192,000), RMB782,000, RMB452,000 and nil.

### *Warranty Provision*

We offer free repair or replacement of defective products to our customers during the warranty period. We do not make provision for warranty costs and we have no separately identifiable repair and maintenance costs. Defective products returned by our customers are reworked by our factories. The amount of rework can be as little as further fine tuning to replacing major components. After being reworked, the products will either be returned back to our customers or sold. The material costs and labor costs for the rework is absorbed and allocated to the total number of products manufactured in that month. As product warranty costs had not been significant during 2006, 2007, 2008 and the eight months ended August 31, 2009, we found no need to make any provision for product warranties during 2006, 2007, 2008 and the eight months ended August 31, 2009. We also have not had any product recall or third party claims for any damage or loss sustained arising from defective products during 2006, 2007, 2008 and the eight months ended August 31, 2009.

## **PRINCIPAL INCOME STATEMENT COMPONENTS**

### *Revenue.*

We mainly derive our revenue from the manufacture and sale of antennas and base station RF subsystems. Our product portfolio is categorized into three principal groups: antenna systems, base station RF subsystems and coverage extension solutions. We sell our products directly to network operators in China and overseas for deployment into the networks they are constructing. We also sell our products to wireless network solution providers who incorporate our products into their wireless coverage solutions, such as their proprietary base stations, which they then sell to network operators worldwide. Our overseas sales principally consist of our direct sales to overseas networks operators, such as Reliance in India, and overseas factory or inventory hubs of global network solution providers, such as Nokia Siemens Networks headquartered in Finland. We also sell to distributors in Vietnam, Indonesia, Egypt and Mexico.

We believe that throughout 2006, 2007 and most of 2008, PRC domestic network operators delayed or decreased their capital spending in China in anticipation of the issuance of the 3G licenses and that the subsequent build out of 3G networks would be capital intensive. Also, the competition among the vendors of the 2G related products in China was also more intense in 2006, 2007 and 2008, as there was a larger number of capable manufacturers in China while the demand for 2G related products was decreasing. Starting from June 2, 2008, China Telecom acquired the CDMA network from China Unicom, through a series of transactions. On October 6, 2008, China Netcom merged into China Unicom. On January 7, 2009, China's 3G operator licenses for TD-SCDMA, W-CDMA and CDMA2000 networks were issued to China Mobile, China Unicom and China Telecom, respectively.

---

## FINANCIAL INFORMATION

---

We believe that as a result of these events and in particular China Telecom's acquisition of the CDMA network from China Unicom in late 2008, the PRC domestic network operators had clearer directions for capital expenditures for both 2G and 3G related products only since late 2008. Starting from late 2008, we began to increase our sales to PRC domestic network operators 3G related products that commanded higher gross profit margins as there were fewer capable manufacturers that had the technological sophistication to manufacture these products. Starting from January 2009, after the 3G operator licenses were granted to the PRC domestic network operators, we began to see significant increase in the sales of our 3G related products to 3G network operators in China to facilitate their deployment of 3G networks. For the eight months ended August 31, 2009, sales to PRC network operators and solution providers such as ZTE accounted for approximately 91.9% of our total revenue.

In the overseas markets, as our technological sophistication began to be recognized, we began to develop new customer relationships with overseas customers starting from 2006. We were qualified to supply to Reliance in 2006. We began to ramp up the manufacturing of products for Reliance in 2007 and Reliance has continued to be an important customer of ours in 2008. However, Reliance delayed or decreased its network capital expenditures in 2008, which we believe was partially attributable to the global financial and economic crisis that the world is currently experiencing. Since then, Reliance has significantly delayed or decreased its order from us. Our sales to Reliance constituted approximately 17.2%, 11.5% and nil of our total revenues for the years ended December 31, 2007, 2008 and the eight months ended August 31, 2009. We were qualified to supply to Nortel Networks in 2007, and ramp up our production in 2008. However, on January 14, 2009, Nortel Networks filed for protection from creditors under Chapter 11 of the United States Bankruptcy Code, which we believe was also partially attributable to the global financial and economic crisis. Since then, we have significantly decreased our sales to Nortel Networks. Our sales to Nortel Networks constituted approximately 0.7%, 9.4% and 2.5% of our total revenues for the years ended December 31, 2007, 2008 and the eight months ended August 31, 2009.

In 2009, our overseas sales decreased substantially, which we believe was primarily attributable to the reduction in capital outlay by our overseas customers due to the global economic and financial crisis. Notwithstanding, the build up of 3G networks in China had kept our revenue strong. Our total revenues for the years ended December 31, 2006, 2007, 2008 and the eight months ended August 31, 2009, were approximately RMB 361.0 million, RMB 626.8 million, RMB 671.2 million and RMB 632.4 million, respectively.

## FINANCIAL INFORMATION

The following table sets forth the revenue in each of our product groups and as a percentage of our total revenue.

	For the Year Ended December 31,						For the Eight Months Ended August 31,			
	2006		2007		2008		2008		2009	
	RMB	%	RMB	%	RMB	%	RMB	%	RMB	%
	(unaudited)									
	(in thousands, except percentages)									
<b>Total antenna system</b>	186,392	51.7%	268,751	42.9%	260,543	38.8%	129,641	30.4%	276,282	43.7%
CDMA/GSM fixed-downtilt antennas <sup>(3)</sup>	111,001	30.8%	116,681	18.6%	80,663	12.0%	28,761	6.7%	81,795	12.9%
CDMA/GSM remote electric-downtilt antennas <sup>(3)</sup>	845	0.2%	14,134	2.3%	18,728	2.8%	8,847	2.1%	35,976	5.7%
PHS antennas	25,482	7.1%	8,908	1.4%	1,957	0.3%	1,361	0.3%	90	0.0%
Yagi antennas	32,172	8.9%	6,708	1.1%	1,095	0.2%	253	0.1%	276	0.0%
W-CDMA antennas <sup>(2)</sup>	1,238	0.4%	1,287	0.2%	72,059	10.7%	44,350	10.4%	74,404	11.8%
TD-SCDMA antennas <sup>(2)</sup>	38	0.0%	20,823	3.3%	5,711	0.8%	4,564	1.1%	23,488	3.7%
Microwave antennas	10,203	2.8%	82,943	13.2%	62,276	9.3%	34,167	8.0%	30,114	4.8%
Other antennas	5,413	1.5%	17,267	2.8%	18,054	2.7%	7,338	1.7%	30,139	4.8%
<b>Total base station RF subsystem</b>	165,433	45.8%	340,940	54.3%	388,675	57.9%	285,025	66.8%	274,501	43.5%
CDMA2000 RF devices <sup>(2)</sup>	16,382	4.5%	59,049	9.4%	50,757	7.5%	28,784	6.7%	65,151	10.4%
CDMA RF devices <sup>(1)</sup>	37,823	10.5%	34,510	5.5%	33,323	5.0%	28,431	6.7%	17,724	2.8%
GSM RF devices <sup>(1)</sup>	105,506	29.2%	112,910	18.0%	198,490	29.6%	139,102	32.6%	134,540	21.3%
CDMA/GSM RF devices <sup>(1)</sup>	230	0.1%	119,358	19.0%	95,901	14.3%	81,449	19.1%	30,494	4.8%
TD-SCDMA RF devices <sup>(2)</sup>	496	0.1%	9,146	1.5%	2,016	0.3%	1,487	0.3%	1,128	0.2%
W-CDMA RF devices <sup>(2)</sup>	4,684	1.3%	5,228	0.8%	7,548	1.1%	5,512	1.3%	23,014	3.6%
Other devices	312	0.1%	739	0.1%	640	0.1%	260	0.1%	2,450	0.4%
<b>Total coverage extension solution</b>	9,131	2.5%	17,115	2.8%	21,964	3.3%	11,772	2.8%	81,584	12.8%
In-door antennas	6,426	1.8%	4,368	0.7%	4,085	0.6%	3,096	0.7%	721	0.1%
Aesthetic antennass <sup>(3)</sup>	—	—	3,456	0.6%	9,372	1.4%	3,608	0.9%	36,674	5.8%
Other antennas	2,705	0.7%	1,124	0.2%	4,100	0.6%	3,142	0.7%	9,160	1.4%
Electric cables	—	—	8,167	1.3%	4,407	0.7%	1,926	0.5%	35,029	5.5%
<b>Total revenues</b>	<u>360,956</u>	<u>100.0%</u>	<u>626,806</u>	<u>100.0%</u>	<u>671,182</u>	<u>100.0%</u>	<u>426,438</u>	<u>100.0%</u>	<u>632,367</u>	<u>100.0%</u>

*Notes:*

- (1) 2G related products.
- (2) 3G related products.
- (3) Dual usage.

## FINANCIAL INFORMATION

The following table sets forth the revenue in each of our geographic information and as a percentage of our total revenue.

	For the Year Ended December 31,						For the Eight Months Ended August 31,			
	2006		2007		2008		2008		2009	
	RMB	%	RMB	%	RMB	%	RMB	%	RMB	%
	(unaudited)									
	(in thousands, except percentages)									
PRC domestic <sup>(1)</sup>	319,252	88.4%	393,271	62.7%	466,320	69.5%	261,178	61.2%	581,072	91.9%
Overseas										
India	13,905	3.9%	111,166	17.8%	79,342	11.8%	60,033	14.1%	4,594	0.7%
Finland	25,492	7.1%	112,494	17.9%	102,687	15.3%	87,522	20.5%	41,156	6.5%
Others	2,307	0.6%	9,875	1.6%	22,833	3.4%	17,705	4.2%	5,545	0.9%
Subtotal	41,704	11.6%	233,535	37.3%	204,862	30.5%	165,260	38.8%	51,295	8.1%
<b>Total</b>	<b>360,956</b>	<b>100.0%</b>	<b>626,806</b>	<b>100.0%</b>	<b>671,182</b>	<b>100.0%</b>	<b>426,438</b>	<b>100%</b>	<b>632,367</b>	<b>100%</b>

Note:

- (1) Includes sales made to ZTE for both PRC and overseas uses as well as China sourcing offices of international solution providers, such as Nokia Siemens Networks.

The following table sets forth our revenue attributable to sales to our major customers, in absolute terms and as a percentage of our revenue:

	For the Year Ended December 31,						For the Eight Months Ended August 31,			
	2006		2007		2008		2008		2009	
	RMB	%	RMB	%	RMB	%	RMB	%	RMB	%
	(unaudited)									
	(in thousands, except percentages)									
<b>PRC Domestic</b>										
ZTE	166,757	46.2%	248,520	39.7%	237,314	35.4%	120,883	28.3%	231,864	36.7%
China Unicom	36,373	10.1%	18,331	2.9%	34,321	5.1%	6,291	1.5%	148,025	23.4%
China Mobile	39,961	11.1%	40,110	6.4%	37,127	5.5%	19,610	4.6%	56,947	9.0%
China Telecom	19,678	5.4%	9,857	1.6%	10,240	1.5%	592	0.1%	53,265	8.4%
Nokia (China) <sup>(1)</sup>	26,357	7.3%	46,779	7.5%	58,146	8.7%	47,756	11.2%	49,246	7.8%
Nortel Networks	8	—	1,287	0.2%	48,940	7.3%	46,009	10.8%	14,498	2.3%
NEC	348	0.1%	8,341	1.3%	18,816	2.8%	7,043	1.7%	13,770	2.2%
Alcatel-Lucent (China) <sup>(2)</sup>	691	0.2%	—	—	6,212	0.9%	2,638	0.6%	7,427	1.2%
China Netcom	605	0.2%	1,511	0.2%	490	0.1%	—	—	—	—
UTStarcom	19,701	5.4%	6,464	1.0%	1,401	0.2%	1,017	0.2%	27	—
Others	8,773	2.4%	12,071	1.9%	13,313	2.0%	9,339	2.2%	6,003	0.9%
<b>Overseas</b>										
Nokia (overseas) <sup>(1)</sup>	25,492	7.1%	112,494	17.9%	102,687	15.3%	87,522	20.5%	41,156	6.5%
ITI (India)	13,905	3.9%	3,727	0.6%	1,802	0.3%	367	0.1%	4,594	0.7%
Nortel Networks (overseas)	—	—	3,280	0.5%	14,365	2.1%	11,015	2.6%	1,444	0.2%
Alcatel-Lucent (overseas) <sup>(2)</sup>	—	—	—	—	1,233	0.2%	828	0.2%	1,012	0.2%
Reliance (India)	—	—	107,439	17.2%	77,540	11.5%	59,666	14.0%	—	—
Others	2,307	0.6%	6,595	1.1%	7,235	1.1%	5,862	1.4%	3,089	0.5%
<b>Total</b>	<b>360,956</b>	<b>100.0%</b>	<b>626,806</b>	<b>100.0%</b>	<b>671,182</b>	<b>100.0%</b>	<b>426,438</b>	<b>100.0%</b>	<b>632,367</b>	<b>100.0%</b>

Notes:

- (1) The figures represent sales to Nokia Siemens Networks after Nokia's merger with Siemens in early 2007.  
(2) The figures include sales to Lucent prior to Lucent's merger with Alcatel in 2006.

---

## FINANCIAL INFORMATION

---

For further discussion of period-by-period comparison of our revenues, see “Results of Operations — Selected consolidated financial information”.

### *Cost of Sales.*

Cost of sales includes production costs such as direct material costs, direct labor costs, manufacturing overhead, core business tax, extra charges and change of work-in-progress and finished good inventories. In 2006, 2007, 2008 and the eight months ended August 31, 2009, our cost of sales were approximately RMB275.9 million, RMB472.7 million, RMB487.9 million and RMB451.9 million, or approximately 76.4%, 75.4%, 72.7% and 71.5% of our revenues, respectively. The following table sets forth the cost of our production inputs as an approximate percentage of the total cost of production in each of the periods indicated.

	<b>For the Year Ended December 31,</b>			<b>For the Eight Months Ended August 31,</b>	
	<b>2006</b>	<b>2007</b>	<b>2008</b>	<b>2008</b>	<b>2009</b>
				<i>(unaudited)</i>	
Raw materials and components	87.6%	88.4%	85.3%	86.6%	85.9%
Manufacturing overhead	7.9%	7.3%	8.9%	7.7%	8.4%
Labor	4.5%	4.3%	5.8%	5.7%	5.7%
<b>Total cost of production</b>	<u>100.0%</u>	<u>100.0%</u>	<u>100.0%</u>	<u>100.0%</u>	<u>100.0%</u>

### *Gross Profit.*

In 2006, 2007, 2008 and the eight months ended August 31, 2009, our customer base and product mix had changed significantly. In 2006, 2007 and most of 2008, as PRC domestic network operators delayed or decreased their capital spending in China in anticipation of the issuance of 3G licenses, our customer base shifted to overseas customers as our technological sophistication had begun to be recognized internationally. Starting from late 2008, as the global economical crisis negatively affected the overseas markets, the acquisition of China Unicom’s CDMA network by China Telecom and the pending issuance of 3G licenses in China allowed each PRC domestic network operators to have clearer direction for capital expenditures. As a result, our sales of both 2G and 3G related products to the PRC domestic network operators increased significantly starting from late 2008. For the eight months ended August 31, 2009, sales to PRC network operators and solution providers accounted for 91.9% of our total revenue. While sales of 2G related products commanded lower gross profit margins, our sales of 3G related products that commanded higher gross profit margins had made up the difference. In 2006, 2007, 2008 and the eight months ended August 31, 2009, our gross profit margins were approximately 23.6%, 24.6%, 27.3% and 28.5%, respectively.

The following table sets forth the approximate gross profit margins in each of our product group.

	<b>For the Year Ended December 31,</b>			<b>For the Eight Months Ended August 31,</b>	
	<b>2006</b>	<b>2007</b>	<b>2008</b>	<b>2008</b>	<b>2009</b>
				<i>(unaudited)</i>	
Antenna system	24.3%	27.9%	29.4%	30.4%	30.2%
Base station RF subsystem	22.0%	22.0%	25.6%	24.9%	24.9%
Coverage extension solutions	37.8%	23.4%	32.2%	30.3%	35.1%

---

## FINANCIAL INFORMATION

---

### *Other Income.*

Our other income consists of gain on sales of materials and work-in-progress, subsidy income from the PRC government, which sometimes is recognized as deferred income and amortized over a period of time, bank interest income and non-operating income. As a new technology based enterprise, we receive government subsidies for investing in development of telecommunication products and technologies.

### *Distribution and Selling Expenses.*

Our distribution and selling expenses consist primarily of salary expenses paid to our distribution and sales employees, customer development expenses, telecommunications expenses, the costs of advertising, travel, carriages, exhibition admission fees and rent.

### *Administrative Expenses.*

Our administrative expenses include general and administrative expenses. Our general and administrative expenses consist primarily of salary expenses paid to our management and administrative personnel, maintenance of our administrative office, rent and utilities, travel, transportation, amortization of options, social welfare obligations, auditors' and professional fees.

### *Research and Development Costs.*

Our research and development costs consist primarily of salary for our research and development engineers, expenses for raw materials and testing fees as well as depreciation of research, development and testing equipment. The following table sets forth the approximate percentage of our research and development expenditures allocated to each of our product groups during each of the periods indicated.

	<b>For the Year Ended December 31,</b>			<b>For the Eight Months Ended August 31,</b>	
	<b>2006</b>	<b>2007</b>	<b>2008</b>	<b>2008</b>	<b>2009</b>
				<i>(unaudited)</i>	
Antenna systems	41.2%	38.9%	37.7%	37.2%	41.3%
Base station RF subsystems	49.2%	48.1%	44.4%	43.8%	43.6%
Coverage extension solutions	9.6%	13.0%	17.9%	19.0%	15.1%
<b>Total</b>	<u>100%</u>	<u>100%</u>	<u>100%</u>	<u>100%</u>	<u>100%</u>

### *Finance Costs.*

Our finance costs mainly represent interest expense on bank loans. To the extent we increase our reliance on bank loans to finance our working capital requirements, we expect our finance costs to increase.

### *Income Tax Expense.*

Our Company is incorporated in the Cayman Islands and is not subject to the income tax in the Cayman Islands.

MOBI Shenzhen was established in Shenzhen, PRC, on August 12, 1999. In accordance with the tax legislations applicable to MOBI Shenzhen at the time, it was entitled to exemption from PRC enterprise income tax for the two years commencing from its first profit making year of operations, after offsetting all unexpired tax losses carried forward from previous years, and thereafter, entitled to a 50% relief from PRC enterprise income tax of 15% for the next three years. The first year for

---

## FINANCIAL INFORMATION

---

which MOBI Shenzhen recorded profit for PRC tax purpose was the year ended December 31, 2000. Accordingly, the applicable tax rate for MOBI Shenzhen was 7.5% for the year ended December 31, 2006 and 2007. On December 16, 2008, MOBI Shenzhen was recognized as a high new technology company by Shenzhen Science and Technology Bureau, Shenzhen Finance Bureau, Administrator of Local Taxation of Shenzhen Municipality and Shenzhen Municipal office of the State Administration of Taxation, which entitled it to 15% preferential tax rate from PRC enterprise income tax for the next three years starting from 2008. Accordingly, the applicable tax rate for MOBI Shenzhen was 15% for the year ended December 31, 2008 and for the eight months ended August 31, 2009.

The applicable tax rate of MOBI Jian was 33% before year 2007, and according to the New PRC Enterprise Income Tax Law, the applicable tax rate was decreased to 25% starting from January 1, 2008. In accordance with the tax legislations applicable to MOBI Jian, it was entitled to exemption from PRC enterprise income tax for the two years commencing from its first profit making year of operations, after offsetting all unexpired tax losses carried forward from previous years, and thereafter, entitled to a 50% relief from PRC enterprise income tax of 25% for the next three years. Accordingly, the tax rate for MOBI Jian was nil for the period from May 23, 2006 (date of establishment) to December 31, 2006, and 2007, and the tax rate for MOBI Jian is 12.5% for the year ended December 31, 2008 and for the eight months ended August 31, 2009.

The applicable tax rate of MOBI Xian is 25% for the period from April 28, 2008 (date of establishment) to December 31, 2008 and for the eight months ended August 31, 2009.

On March 16, 2007, the PRC promulgated the Law of the People's Republic of China on Enterprise Income Tax by Order No. 63 of the President of the People's Republic of China (the "New PRC Enterprise Income Tax Law"), which became effective on January 1, 2008. On December 6, 2007, the State Council issued Implementation Regulations of the New PRC Enterprise Income Tax Law. According to the New PRC Enterprise Income Tax Law, the Implementation Regulations and other relevant interpretative documents, the following transitional tax policies are applicable to our PRC subsidiaries in lieu of the former preferential income tax rate before the taking effect of the New PRC Enterprise Income Tax Law: the preferential income tax rate of 15% applicable to any enterprise before the taking effect of the New PRC Enterprise Income Tax Law will be increased to 25% on a gradual basis over five years starting from year 2008, which means that the income tax rate will be 18%, 20%, 22%, 24% and 25% from year 2008 to year 2012 respectively. As for those enterprises which enjoy the preferential tax treatment that their income tax will be exempted for the first two years starting from its first profit making year of operations, and for the following three years, their income tax payable will be halved, they are entitled to continue to enjoy the aforesaid preferential tax treatment after January 1, 2008 until the expiration of the same. However, if any of the said enterprises has not yet enjoyed the aforesaid preferential tax treatment due to the fact that it has not yet making profits, the term of the aforesaid preferential tax treatment applicable to such enterprise shall be commenced from year 2008. In addition, in case there is overlapping between the aforesaid transitional tax policies and the relevant preferential tax policies set forth in the New PRC Enterprise Income Tax Law and the Implementation Regulations, the enterprises shall have the discretion to choose the most favorable tax policies to be applicable to them. MOBI Shenzhen and MOBI Jian are the only two PRC Subsidiaries that currently enjoy certain tax exemption and reduction treatment, among which MOBI Shenzhen has chosen the preferential income tax rate of 15% applicable to high new technology companies in accordance with the New PRC Enterprise Income Tax Law, and MOBI Jian still enjoys the preferential tax treatment that its income tax payable is halved for the term of three years. Both of the aforesaid two subsidiaries are entitled to continue to enjoy the preferential tax treatment until the expiration of the same. On the other hand, MOBI Xian adopts a unified income tax rate of 25% according to the New PRC Enterprise Income Tax Law and does not enjoy any preferential tax treatment.

---

## FINANCIAL INFORMATION

---

### RESULTS OF OPERATIONS

#### Selected consolidated financial information

The following table is a summary of our consolidated audited results for each of the periods indicated. The selected consolidated statements of comprehensive income data presented below for the periods indicated is derived from our audited consolidated financial statements included in Appendix I — “Accountants’ Report” and you should read the entire financial statements included therein, including the notes thereto, for more details.

	For the Year Ended December 31,			For the Eight Months Ended August 31,	
	2006	2007	2008	2008	2009
	<i>(unaudited)</i>				
	<i>(RMB in thousands)</i>				
Revenue	360,956	626,806	671,182	426,438	632,367
Cost of sales	<u>(275,888)</u>	<u>(472,674)</u>	<u>(487,884)</u>	<u>(312,593)</u>	<u>(451,873)</u>
Gross profit	85,068	154,132	183,298	113,845	180,494
Other income	3,741	2,943	7,103	3,647	3,610
Research and development costs	(15,171)	(24,945)	(34,550)	(21,654)	(21,305)
Distribution and selling expenses	(19,223)	(27,875)	(35,170)	(17,606)	(32,055)
Administrative expenses	(20,762)	(41,819)	(47,401)	(31,766)	(31,181)
Finance costs	<u>(153)</u>	<u>(2,899)</u>	<u>(3,803)</u>	<u>(2,932)</u>	<u>(2,664)</u>
Profit before taxation	33,500	59,537	69,477	43,534	96,899
Income tax expense	<u>(2,019)</u>	<u>(2,764)</u>	<u>(7,552)</u>	<u>(6,186)</u>	<u>(12,694)</u>
Profit and the total comprehensive income for the year/period and attributable to owners of our Company	<u>31,481</u>	<u>56,773</u>	<u>61,925</u>	<u>37,348</u>	<u>84,205</u>

---

## FINANCIAL INFORMATION

---

The following table sets forth our selected consolidated statement of comprehensive income data as an approximate percentage of our revenues for each of the periods indicated:

	For the Year Ended December 31,			For the Eight Months Ended August 31,	
	2006	2007	2008	2008	2009
				<i>(unaudited)</i>	
Revenue	100.0%	100.0%	100.0%	100.0%	100.0%
Cost of sales	(76.4%)	(75.4%)	(72.7%)	(73.3%)	(71.5%)
Gross profit	23.6%	24.6%	27.3%	26.7%	28.5%
Other income	1.0%	0.5%	1.1%	0.9%	0.6%
Research and development costs	(4.2%)	(4.0%)	(5.1%)	(5.1%)	(3.4%)
Distribution and selling expenses	(5.3%)	(4.4%)	(5.2%)	(4.1%)	(5.1%)
Administrative expenses	(5.8%)	(6.7%)	(7.1%)	(7.4%)	(4.9%)
Finance costs	—	(0.5%)	(0.6%)	(0.7%)	(0.4%)
Profit before taxation	9.3%	9.5%	10.4%	10.2%	15.3%
Income tax expense	(0.6%)	(0.4%)	(1.1%)	(1.5%)	(2.0%)
Profit and the total comprehensive income for the year/period and attributable to owners of our Company	<u>8.7%</u>	<u>9.1%</u>	<u>9.2%</u>	<u>8.8%</u>	<u>13.3%</u>

### **Eight months ended August 31, 2008 compared with eight months ended August 31, 2009**

*Revenue.* Revenue increased by approximately RMB205.9 million, or approximately 48.3%, from approximately RMB426.4 million in the eight months ended August 31, 2008 to approximately RMB632.4 million in the eight months ended August 31, 2009. Sales of our antenna system and coverage extension solution product groups increased by approximately RMB146.6 million and RMB69.8 million, respectively, while sales of our base station RF subsystem products decreased by approximately RMB10.5 million.

Starting from January 7, 2009, after the 3G operator licenses were granted to the PRC domestic network operators, we began to see significant increase in the sales of our 3G related products to 3G network operators in China to facilitate their deployment of 3G networks. For the eight months ended August 31, 2009, sales to PRC network operators and solution providers accounted for approximately 91.9% of our total revenue. The increase in sales of our antenna system products were due primarily to increases in sales of CDMA/GSM fixed-downtilt antenna, CDMA/GSM remote electric-downtilt antenna, W-CDMA antenna and TD-SCDMA antenna products and offset in part primarily by a decrease in sales of our microwave antenna products. The slight decrease in sales of our base station RF subsystem products were due primarily to a decrease in sales of CDMA/GSM device products and offset in part primarily by an increase in sales of CDMA and W-CDMA device products. The increase in sales of our coverage extension solutions products was due primarily to an increase in sales of our electric cable and aesthetic antenna products.

In the overseas market, the global financial and economic crisis continued to negatively affect our overseas sales in the eight months ended August 31, 2009. Reliance had delayed or decreased its network capital expenditures in 2008, which we believe was partially attributable to the global financial and economic crisis that the world is currently experiencing. Since then, Reliance has significantly decreased its order from us. In comparison, our sales to Reliance constituted approximately 17.2%, 11.5% and nil of our total revenue for the years ended December 31, 2007, 2008 and the eight months ended August 31, 2009. Further, on January 14, 2009, Nortel Networks filed for

---

## FINANCIAL INFORMATION

---

protection from creditors under Chapter 11 of the United States Bankruptcy Code, which we believe was also partially attributable to the global financial and economic crisis. Since then, we have also significantly decreased our sales to Nortel Networks. Our sales to Nortel Networks constituted approximately 0.7%, 9.4% and 2.5% of our total revenue for the years ended December 31, 2007, 2008 and the eight months ended August 31, 2009.

*Cost of Sales.* Cost of sales increased by approximately RMB139.3 million, or approximately 44.6%, from approximately RMB312.6 million in the eight months ended August 31, 2008 to approximately RMB451.9 million in the eight months ended August 31, 2009. The increase was substantially in line with the increase in our revenue.

*Gross Profit.* As a result of the increase in our revenue, our gross profit increased by approximately RMB66.6 million, or approximately 58.5%, from approximately RMB113.8 million in the eight months ended August 31, 2008 to approximately RMB180.5 million in the eight months ended August 31, 2009. Our gross profit margin was approximately 26.7% in the eight months ended August 31, 2008 compared to approximately 28.5% in the eight months ended August 31, 2009. The increase in our gross profit margin was due primarily to an increase in sales of 3G related products that commanded higher gross profit margins, while the gross profit margin for our older models relating to 2G and PHS protocols decreased during this period.

*Other Income.* Other income decreased by approximately RMB37,000, or approximately 1.0%, from approximately RMB3.65 million in the eight months ended August 31, 2008 to approximately RMB3.61 million in the eight months ended August 31, 2009.

*Distribution and Selling Expenses.* Distribution and selling expenses increased by approximately RMB14.4 million, or approximately 82.1%, from approximately RMB17.6 million in the eight months ended August 31, 2008 to approximately RMB32.1 million in the eight months ended August 31, 2009. This increase was due primarily to increased sales activities as the scale of our operation grew and for increased transportation costs for the deployment of our products in China.

*Administrative Expenses.* Administrative expenses decreased by approximately RMB0.6 million, or approximately 1.8%, from approximately RMB31.8 million in the eight months ended August 31, 2008 to approximately RMB31.2 million in the eight months ended August 31, 2009. We did not have any significant changes in our general and administrative expenses in these two periods.

*Research and Development Costs.* Research and development costs decreased by approximately RMB349,000, or approximately 1.6%, from approximately RMB21.7 million in the eight months ended August 31, 2008 to approximately RMB21.3 million in the eight months ended August 31, 2009. We did not have any significant changes in our research and development costs in these two periods.

*Profit Before Taxation.* Profit before taxation increased by approximately RMB53.4 million, or approximately 122.6%, from approximately RMB43.5 million in the eight months ended August 31, 2008 to approximately RMB96.9 million in the eight months ended August 31, 2009.

*Income Tax Expense.* Our income tax expenses increased by approximately RMB6.5 million, or approximately 105.2%, from approximately RMB6.2 million in the eight months ended August 31, 2008 to approximately RMB12.7 million in the eight months ended August 31, 2009. Our effective tax rates calculated from the tax charged to the consolidated statements of comprehensive income over the profit before tax were approximately 14.2% and 13.1% for the eight months ended August 31, 2008 and eight months ended August 31, 2009, respectively.

*Profit for the Period.* Profit for the period increased by approximately RMB46.9 million, or approximately 125.5%, from approximately RMB37.3 million in the eight months ended August 31, 2008 to approximately RMB84.2 million in the eight months ended August 31, 2009. Our net profit margin was approximately 8.8% in the eight months ended August 31, 2008, compared to

---

## FINANCIAL INFORMATION

---

approximately 13.3% in the eight months ended August 31, 2009. The increase in our net profit margin was due primarily to an increase in sales of 3G related products that commanded higher net profit margins than the sales of 2G related products, as well as the efficiency brought about by our increased economy of scale.

### **2008 compared with 2007**

*Revenue.* Revenue increased by approximately RMB44.4 million, or approximately 7.1%, from approximately RMB626.8 million in 2007 to approximately RMB671.2 million in 2008. Sales of our antennas system products decreased by approximately RMB8.2 million, while sales of our base station subsystems and coverage extension solutions product groups increased by approximately RMB47.7 million and approximately RMB4.8 million, respectively.

The decrease in sales of our antenna system products was due primarily to the decrease in sales of yagi antennas that are used in remote villages in China, as 2G deployment to remote villages in China has slowed down, a decrease in sales of PHS antennas as the PHS protocol became outmoded due to limited bandwidth and coverage area, and a decrease in sales of TD-SCDMA antennas as PRC domestic network operators (other than China Unicom) completed field-testing of 3G networks and were delaying their capital spending before the 3G licenses were issued. The decrease in sales of our antenna system products was offset in part primarily by an increase in sales of W-CDMA antennas, as China Unicom increased its capital expenditures, including capital spending for W-CDMA network, after selling its CDMA network to China Telecom on a series of transactions starting from June 2, 2008.

The increase in sales of our base station RF subsystem products was due primarily to an increase in sales of our GSM RF devices due primarily to China Unicom began to increase its network build up after selling its CDMA network to China Telecom. The increase in sales of our base station RF subsystem was offset in part primarily by the decrease in sales of our CDMA2000 RF devices and TD-SCDMA RF devices, as PRC domestic network operators, other than China Unicom, continued to delay or decrease their capital spending in 2008 pending the issuance of 3G licenses. The increase in sales of our coverage solution products was due primarily to an increase in sales of our aesthetic antennas to PRC network operators.

We believe the overall increase in revenue can also be attributable to our technology sophistication began to be recognized internationally. In 2008, our sales to international or overseas network solution providers Nortel Networks and NEC increased by approximately RMB58.7 million and RMB10.5 million, respectively. This increase was offset in part primarily by a decrease in sales to certain overseas network operators including Reliance in India, which we believe was partially attributable to the global economic and financial crisis. Domestically, after China Unicom sold its CDMA networks to China Telecom, China Unicom increased the build up of both of its GSM and W-CDMA networks. Our sales to China Unicom increased by RMB16.0 million.

*Cost of Sales.* Cost of sales increased by approximately RMB15.2 million, or approximately 3.2%, from approximately RMB472.7 million in 2007 to approximately RMB487.9 million in 2008. The increase was substantially in line with the increase in our revenue.

*Gross Profit.* As a result of the increase in our revenue, our gross profit increased by approximately RMB29.2 million, or approximately 18.9%, from approximately RMB154.1 million in 2007 to approximately RMB183.3 million in 2008. Our gross profit margin was approximately 27.3% in 2008 compared to approximately 24.6% in 2007. In 2008, we were able to obtain higher gross profit margins for sales to certain overseas customers such as Reliance as there was less competition in the emerging markets such as India, while the gross profit margin for our antenna products relating to 2G and PHS protocols decreased during this period. We had also developed new products involving 3G technology or customized products to specific customer requirements that commanded higher gross margins that were primarily sold to Nokia Siemens Networks and ZTE.

---

## FINANCIAL INFORMATION

---

*Other Income.* Other income increased by approximately RMB4.2 million, or approximately 141.4%, from approximately RMB2.9 million in 2007 to approximately RMB7.1 million in 2008. This increase was due primarily to government grants for certain research projects and tax refund.

*Distribution and Selling Expenses.* Distribution and selling expenses increased by approximately RMB7.3 million, or 26.2%, from approximately RMB27.9 million in 2007 to approximately RMB35.2 million in 2008. This increase was due primarily to an increase due to an increased number of employees and sales activities as the scale of our operation grew and for increased transportation costs for the deployment of our products in China when PRC domestic network operators began to increase their purchases in late 2008. This increase was offset in part primarily by a decrease in sales activities overseas, as certain of our overseas customers decreased their purchases in light of the global financial and economic crisis.

*Administrative Expenses.* Administrative expenses increased by approximately RMB5.6 million, or approximately 13.3%, from approximately RMB41.8 million in 2007 to approximately RMB47.4 million in 2008. This increase was due primarily to an increase in the number of employees as the scale of our operation grew.

*Research and Development Costs.* Research and development costs increased by approximately RMB9.6 million, or approximately 38.5%, from approximately RMB24.9 million in 2007 to approximately RMB34.6 million in 2008. This increase was due primarily to an increase in employee expenses for our research and development engineers, as we increased the number of our recruits in order to keep up with our product development plans, and new product development expenses.

*Finance Costs.* Finance costs increased by approximately RMB0.9 million, or approximately 31.2%, from approximately RMB2.9 million in 2007 to approximately RMB3.8 million in 2008. This increase was due primarily to an increase in the amount of our bank borrowing and a slight increase in interest rate.

*Profit Before Taxation.* Profit before taxation increased by approximately RMB9.9 million, or approximately 16.7%, from approximately RMB59.5 million in 2007 to approximately RMB69.5 million in 2008.

*Income Tax Expense.* Our income tax expenses increased by approximately RMB4.8 million, or approximately 173.2%, from approximately RMB2.8 million in 2007 to approximately RMB7.6 million in 2008. Our effective tax rates calculated from the tax charged to the consolidated statements of comprehensive income over the profit before tax were approximately 4.6% and 10.9% for 2007 and 2008, respectively.

*Profit for the Year.* Profit for the year increased by approximately RMB5.2 million, or approximately 9.1%, from approximately RMB56.8 million in 2007 to approximately RMB61.9 million in 2008. Our net profit margin was approximately 9.2% in 2008, compared to approximately 9.1% in 2007.

### **2007 compared with 2006**

*Revenue.* Revenue increased by approximately RMB265.9 million, or approximately 73.7%, from approximately RMB361.0 million in 2006 to approximately RMB626.8 million in 2007. Sales of our antenna system, base station RF subsystem and coverage extension solution product groups increased by approximately RMB82.4 million, RMB175.5 million and RMB8.0 million, respectively. The increase in sales of our antenna system products was due primarily to an increase in sales of products relating to microwave antennas for long distance infrastructure networks, TD-SCDMA products for trial networks in China and remote electric downtilt antennas for CDMA/GSM dual protocols, which we were one of the price/technology leader. The increase in sales of our antenna system products was offset in part primarily by a decrease in sales of our yagi antennas that are used in remote villages in China, as 2G deployment to remote villages in China has slowed down and a decrease in sales of our

---

## FINANCIAL INFORMATION

---

PHS antennas as the PHS protocol became outmoded due to limited bandwidth and coverage area. The increase in sales of our base station RF subsystem products was due primarily to an increase in sales of our CDMA/GSM dual protocol RF devices, CDMA2000 RF devices, TD-SCDMA RF devices and GSM RF devices. This increase was offset in part primarily by a decrease in sales of our CDMA RF devices. The increase in sales of our coverage extension products was due primarily to an increase in sales of our electric cables, and was offset in part primarily by a decrease in sales of our in-door and other antennas.

We believe the overall increase in revenue can also be attributable to an increase in demand for our products overseas. This increase in demand for our products came primarily from our global network solution provider customers, such as ZTE and Nokia Siemens Networks, and network operator customers in the emerging markets, such as Reliance in India. Sales to ZTE, Nokia Siemens Networks and Reliance increased by approximately RMB81.8 million, RMB107.4 million and RMB107.4 million, respectively. This increase was offset in part primarily by a decrease in sales to PRC domestic network solution providers and network operators as the PRC domestic network operators delayed or decreased their capital spending ahead of the issuance of 3G licenses.

*Cost of Sales.* Cost of sales increased by approximately RMB196.8 million, or approximately 71.3%, from approximately RMB275.9 million in 2006 to approximately RMB472.7 million in 2007. The increase was substantially in line with the increase in our revenue.

*Gross Profit.* As a result of the increase in our revenue, our gross profit increased by approximately RMB69.1 million, or approximately 81.2%, from approximately RMB85.1 million in 2006 to approximately RMB154.1 million in 2007. Our gross profit margin was approximately 24.6% in 2007 compared with approximately 23.6% in 2006. We were able to obtain higher gross profit margins for sales to certain overseas customers such as Reliance as there was less competition in the emerging markets such as India. We had also developed new products involving 3G technology or customized products to specific customer requirements that commanded higher gross margins. These products were primarily sold to Nokia Siemens Networks and ZTE. The gross profit for our older models relating to 2G and PHS protocols decreased during this period.

*Other Income.* Other income decreased by approximately RMB0.8 million, or approximately 21.3%, from approximately RMB 3.7 million in 2006 to approximately RMB2.9 million in 2007.

*Distribution and Selling Expenses.* Distribution and selling expenses increased by approximately RMB8.7 million, or approximately 45.0%, from approximately RMB19.2 million in 2006 to approximately RMB27.9 million in 2007. This increase was due primarily to an increase in the number of employees and sales activities both domestically and overseas as the scale of our operation grew.

*Administrative Expenses.* Administrative expenses increased by approximately RMB21.1 million, or approximately 101.4%, from approximately RMB20.8 million in 2006 to approximately RMB41.8 million in 2007. This increase was due primarily to an increase in the number of employees as the scale of our operation grew and certain one-time accounting and professional fees.

*Research and Development Costs.* Research and development costs increased by approximately RMB9.8 million, or approximately 64.4%, from approximately RMB15.2 million in 2006 to approximately RMB24.9 million in 2007. This increase was due primarily to increases in material costs and testing fees for product development and employee expenses for our research and development engineers, as we increased the number of our recruits in order to keep up with our product development plans.

*Financing Costs.* Financing costs increased by approximately RMB2.7 million, or approximately 1,794.8%, from approximately RMB0.2 million in 2006 to approximately RMB2.9 million in 2007. This increase was due primarily to an increase in bank borrowing that resulted in an increase in interest payments.

---

## FINANCIAL INFORMATION

---

*Profit Before Taxation.* Profit before taxation increased by approximately RMB26.0 million, or approximately 77.7%, from approximately RMB33.5 million in 2006 to approximately RMB59.5 million in 2007.

*Income Tax Expense.* Our income tax expenses increased by approximately RMB0.7 million, or approximately 36.9% from approximately RMB2.0 million in 2006 to approximately RMB2.8 million in 2007. Our effective tax rates calculated from the tax charged to the consolidated statements of comprehensive income over the profit before tax were approximately 6.0% and 4.6% for 2006 and 2007, respectively.

*Profit for the Year.* Profit for the year increased by approximately RMB25.3 million, or approximately 80.3%, from approximately RMB31.5 million in 2006 to approximately RMB56.8 million in 2007. Our net profit margin was approximately 9.1% in 2007, compared to approximately 8.7% in 2006. Our profit for the year improved in 2007 compared to 2006 primarily as a result of our increased sales of certain existing antenna system products to newly developed overseas customers, such as Reliance, and newly developed antenna system and base station RF subsystem products relating to the GSM, CDMA, CDMA2000 and TD-SCDMA protocols to existing customers.

## FINANCIAL INFORMATION

### ANALYSIS OF FINANCIAL POSITION

The following table sets forth financial information in our consolidated statements of financial position as of December 31, 2006, 2007, 2008 and August 31, 2009. Such financial information is extracted from the Accountants' Report included in Appendix I to this prospectus and you should read the entire financial statements included therein, including the notes thereto, for more details.

	As of December 31,			As of
	2006	2007	2008	August 31,
	<i>(RMB in thousands)</i>			
<b>Selected Consolidated Statements of Financial Position</b>				
Non-current assets				
Property, plant and equipment	70,253	89,029	107,484	117,711
Prepaid lease payments	4,324	4,233	21,570	21,303
Deferred tax assets	—	1,527	6,000	7,384
	<u>74,577</u>	<u>94,789</u>	<u>135,054</u>	<u>146,398</u>
Current assets				
Inventories	51,808	127,442	222,049	290,767
Trade and other receivables	205,882	280,747	362,159	513,902
Prepaid lease payments	98	98	471	453
Pledged bank balances	1,308	8,006	14,739	41,592
Bank balances and cash	43,080	131,470	59,067	69,203
	<u>302,176</u>	<u>547,763</u>	<u>658,485</u>	<u>915,917</u>
Current liabilities				
Trade and other payables	153,327	281,500	380,311	490,370
Dividend payable	—	—	429	758
Tax payable	495	2,404	8,033	11,325
Entrusted bank loan	—	5,000	—	—
Short-term bank borrowings	7,909	69,500	73,454	157,744
Deferred income	54	563	563	746
Provision	500	500	500	500
	<u>162,285</u>	<u>359,467</u>	<u>463,290</u>	<u>661,443</u>
Net current assets	<u>139,891</u>	<u>188,296</u>	<u>195,195</u>	<u>254,474</u>
Total assets less current liabilities	<u>214,468</u>	<u>283,085</u>	<u>330,249</u>	<u>400,872</u>
Non-current liabilities				
Deferred income	1,297	3,236	2,673	3,600
Net assets	<u>213,171</u>	<u>279,849</u>	<u>327,576</u>	<u>397,272</u>
Capital and reserves				
Share capital	1	1	1	1
Reserves	<u>213,170</u>	<u>279,848</u>	<u>327,575</u>	<u>397,271</u>
Equity attributable to owners of our Company	<u>213,171</u>	<u>279,849</u>	<u>327,576</u>	<u>397,272</u>

---

## FINANCIAL INFORMATION

---

### Property, Plant and Equipment

Property, plant and equipment consists of buildings, furniture fixtures and equipment, leasehold improvements, motor vehicles, plant and machinery and construction-in-progress. As of December 31, 2006, 2007, 2008 and August 31, 2009, property, plant and equipment amounted to approximately RMB70.3 million, RMB89.0 million, RMB107.5 million and RMB117.7 million, respectively. The increases were due primarily to purchase of new equipment for the research and development department and for capacity expansion.

### Prepaid Lease Payment

Prepaid lease payment consists of the payment for the right to occupy and use certain parcels of land held by us. As of the Latest Practicable Date, we held three parcels of land, including the land in Shenzhen where our Nanshan Manufacturing Facility is located and a parcel of land in Jian where our Jizhou Manufacturing Facility is located and a parcel of land in Xian where our Xian facility is located. The table below sets forth the prepaid lease payment for during each of the periods indicated.

	<b>For the Year Ended</b>			<b>For the Eight</b>
	<b>December 31,</b>			<b>Months Ended</b>
	<b>2006</b>	<b>2007</b>	<b>2008</b>	<b>August 31,</b>
	<i>(RMB in thousands)</i>			<b>2009</b>
Land use right in the PRC				
Medium term lease	4,422	4,331	22,041	21,756
Analysed for reporting purposes as:				
Current portion	98	98	471	453
Non-current portion	4,324	4,233	21,570	21,303
	<u>4,422</u>	<u>4,331</u>	<u>22,041</u>	<u>21,756</u>

### Current Asset/(Liabilities)

We have current assets of approximately RMB302.2 million, RMB547.8 million, RMB658.5 million, RMB915.9 million and RMB954.1 million, as of December 31, 2006, 2007, 2008 and August and October 31, 2009. We have current liabilities of approximately RMB162.3 million, RMB359.5 million, RMB463.3 million, RMB661.4 million and RMB682.6 million as of December 31, 2006, 2007, 2008 and August and October 31, 2009. Our current assets have mainly consisted of inventories, trade receivables, notes receivable, other receivables, pledged bank balances, cash and bank balances. Our current liabilities have mainly consisted of trade payables, notes payable, other payables, tax payable and bank borrowing.

Our net current assets have been increased during 2006, 2007, 2008 and the eight months ended August 31, 2009. Due to the significant revenue growth during the year ended December 31, 2007 and the period ended August 31, 2009, our net current assets increased significantly as of December 31, 2007 and August 31, 2009 comparing to that as of December 31, 2006 and December 31, 2008, respectively.

---

## FINANCIAL INFORMATION

---

### Inventories

The following table sets out a summary of our inventory balances at the end of each reporting period indicated, as well as the turnover days of our inventory for the periods indicated.

	<b>As of December 31,</b>			<b>As of</b>
	<b>2006</b>	<b>2007</b>	<b>2008</b>	<b>August 31,</b>
	<i>(RMB in thousands)</i>			<b>2009</b>
Raw materials	12,840	46,534	50,192	63,612
Work-in-progress	3,926	19,020	20,303	35,336
Finished goods	35,042	61,888	151,554	191,819
	<u>51,808</u>	<u>127,442</u>	<u>222,049</u>	<u>290,767</u>

As of October 31, 2009, we used up approximately RMB37.1 million and RMB30.7 million of the RMB63.6 million and RMB35.3 million of raw materials and work-in-progress outstanding as of August 31, 2009 and sold approximately RMB86.0 million of the RMB192.0 million finished good outstanding as of August 31, 2009.

Our sales and marketing managers review our inventory ageing list on a periodical basis for those aged inventories throughout 2006, 2007, 2008 and the eight months ended August 31, 2009. This involves comparison of carrying value of the aged inventory items with the respective net realizable value. The purpose of the comparison is to ascertain whether allowance is required to be made for any obsolete and slow-moving items. For the years ended December 31, 2006, 2007, 2008 and the eight months ended August 31, 2009, our inventory write-downs were approximately RMB1.1 million, RMB1,000, RMB0.4 million and RMB0.7 million, respectively. We recorded inventory write-down during 2006, 2007, 2008 and the eight months ended August 31, 2009 due to lower net realizable value comparing to carrying value of the aged inventory items.

Our inventory balance increased by approximately RMB75.6 million, or approximately 146.0%, from approximately RMB51.8 million as of December 31, 2006 to approximately RMB127.4 million as of December 31, 2007, as we increased our sales to overseas customers. Our inventory balance increased by approximately RMB94.6 million, or approximately 74.2%, from approximately RMB127.4 million as of December 31, 2007 to approximately RMB222.0 million as of December 31, 2008 due primarily to an increase in our inventory in finished goods in products related to the 3G standard, as we anticipated an increased demand once the 3G operator licenses are granted in China. Our sales to overseas customers slowed down in late 2008 as a result of the global economic and financial crisis. Our inventory balance increased by approximately RMB68.7 million, or approximately 31.0%, from approximately RMB222.0 million as of December 31, 2008 to approximately RMB290.8 million as of August 31, 2009 due primarily to our increased scale of operation.

Turnover days of inventory are derived by dividing the arithmetic mean of the beginning and ending balances of inventory for the relevant period by cost of sales and multiplying by the number of days in the period. Our inventory turnover days were 70 days, 69 days, 131 days and 138 days in 2006, 2007, 2008 and the eight months period ended August 31, 2009. Our inventory turnover days generally remain the same, from 70 days in 2006 to 69 days in 2007. The increase in inventory turnover days from 69 days in 2007 to 131 days in 2008 was attributable primarily to an increase in our inventory in finished goods. As our scale of operation grew in 2009, we maintained a higher level of inventory as of August 31, 2009.

---

## FINANCIAL INFORMATION

---

### Trade and other receivables

Our trade receivables represent receivables from the sales of our antennas and base station RF subsystems.

We offer credit terms generally accepted in the antennas and base station RF subsystems manufacturing industry to our trade customers, which for a significant number of our products is around 30 to 120 days, although longer credit terms may be extended to certain customers, depending on price, the size of the contract, credibility and reputation of the customers. In order to manage the credit risks associated with trade receivables effectively, credit limits of customers are evaluated periodically.

In order to minimize the credit risk, our management has delegated a team of at least four members, depending on the customer account, headed by our Vice President in Sales and Marketing, to be responsible for determination of credit limits, credit approvals and other monitoring procedures to ensure that follow-up action is taken to recover overdue debts. In this regard, our directors consider our credit risk to be significantly reduced.

An ageing analysis of our trade receivables at the end of each reporting period indicated is set forth below, based on the invoice date, as well as the turnover days of our trade receivables for the periods indicated:

Age	As of December 31,			As of
	2006	2007	2008	August 31, 2009
	<i>(RMB in thousands)</i>			
0 to 30 days	63,375	66,350	85,521	77,470
31 to 60 days	30,135	75,335	39,049	71,558
61 to 90 days	10,589	16,543	14,036	38,724
91 to 120 days	6,102	5,287	36,017	34,731
121 to 180 days	4,651	8,140	5,161	24,923
Over 180 days	30,068	34,133	25,740	65,319
	<u>144,920</u>	<u>205,788</u>	<u>205,524</u>	<u>312,725</u>

As of October 31, 2009, approximately RMB151.3 million of the RMB312.7 million trade receivables outstanding as of August 31, 2009 were settled.

Turnover days of trade receivables are derived by dividing the arithmetic mean of the opening and closing balances of net trade and note receivables for the relevant period by revenue and multiplying by the number of days in the period. As such, the analysis of trade receivable turnover days can be influenced by the amount of outstanding receivable at either the opening or closing date of the particular period being analyzed. For instance, in periods where we experienced rapid growth, our trade receivable balance was higher at the closing date of such periods, which in turn resulted in a higher arithmetic means in the calculation of turnover days. Our revenues also fluctuated significantly due to a number of factors that are not periodic or seasonal. See “Risk Factors — We have experienced, and will continue to experience, significant fluctuations in sales and operating results from period to period.” As these factors are not seasonal and do not correspond to the opening and closing date of a particular period, our turnover days analysis may not be as indicative as other companies whose revenues fluctuate seasonally.

---

## FINANCIAL INFORMATION

---

Trade receivable turnover days were 163 days, 135 days, 167 days and 164 days in 2006, 2007, 2008 and the eight months period ended August 31, 2009. The decrease in trade receivable turnover days, from 163 days in 2006 to 135 days in 2007, was attributable primarily to an increase in sales to certain overseas customers to whom we extended a shorter credit period, and a general improvement in our receivable management throughout 2007. The increase in trade receivable turnover days from 135 days in 2007 to 167 days in 2008 was attributable primarily to us extending a longer credit period to certain overseas customers as a result of the global economic and financial crisis and an increase in sales to certain PRC domestic network operator customers in late 2008, for which we generally granted a much longer credit period than the credit period for overseas customers. As a result of us increasing our sales to PRC domestic network operator customers, who enjoy a longer credit period, the trade receivable turnover days remain to be high for the eight months ended August 31, 2009. See “Business — Sales and Marketing — Sales to PRC network operators” for more detailed descriptions of the credit terms of our PRC network operator customers.

Historically, the trade receivables outstanding over 180 days were substantially attributable to the PRC network operators. Our management considers our historical experiences with such customers, the goods and services provided to such customers, our relationship with such customers and their financial creditability in order to determine the level of provision for bad and doubtful debt. For 2006, 2007, 2008 and the eight months ended August 31, 2009, our (reversal of provision for)/provision for bad and doubtful debts were approximately RMB(0.2) million, RMB0.8 million, RMB0.5 million and nil, respectively.

Our other receivables and prepayments consist of the following:

	<b>As of December 31,</b>			<b>As of</b>
	<b>2006</b>	<b>2007</b>	<b>2008</b>	<b>August 31,</b>
	<i>(RMB in thousands)</i>			<b>2009</b>
Other receivables from employees	693	1,467	2,159	2,313
Other receivables from utilities	273	313	451	559
Prepaid expenses and sundry receivables	12	146	374	593
Legal advisory and other professional expenses for IPO	—	5,441	5,420	5,417
Value Added Tax	863	4,656	—	—
Patent application expenditure	75	112	140	128
Total other receivable and prepayment	<u>1,916</u>	<u>12,135</u>	<u>8,544</u>	<u>9,010</u>

Other receivables and prepayments principally represent advances to employees for various business trips, value added taxes and professional expenses. Advances to employees increase in periods where we undertook extended marketing activities, especially for overseas markets. The balance of Value Added Tax reflect the balance of input Value Added Tax less the balance of output Value Added Tax.

### Trade and other payables

Our trade payables represent amounts payable for purchases of raw materials and components from various suppliers. Our suppliers typically offer us credit terms of 90 days, based on the invoice date.

---

## FINANCIAL INFORMATION

---

We record our trade payable on the consolidated statements of financial position based on the estimated value of the raw materials and components received by our warehouse. After inventorying the delivery, we generally discuss with our suppliers regarding any quality, shortage or surplus issue. It generally takes several weeks to two months after our receipt of delivery before our suppliers would issue us an undisputable invoice. We typically have credit terms of 90 days after we receive the undisputable invoice from our suppliers. As of the Latest Practicable Date, we have maintained good relationship with our suppliers.

An ageing analysis of our trade payables at the end of each reporting period indicated, as well as the turnover days of our trade payables for the periods indicated is set forth below:

Age	As of December 31,			As of
	2006	2007	2008	August 31, 2009
	<i>(RMB in thousands)</i>			
0 to 30 days	29,552	29,679	63,063	40,636
31 to 60 days	29,730	37,009	36,677	40,382
61 to 90 days	17,730	38,336	40,099	42,713
90 to 180 days	29,867	124,244	55,409	153,479
Over 180 days	1,879	1,035	3,228	38,250
	108,758	230,303	198,476	315,460

As of October 31, 2009, we settled approximately RMB119.2 million of the RMB315.5 million trade payables outstanding as of August 31, 2009.

Our trade payable aged 90-180 days and over 180 days increased significantly as of August 31, 2009 compared to the trade payable aged 90-180 days and over 180 days as of December 31, 2008, due primarily to an increase in orders we made to our suppliers starting from the first quarter of 2009, as we anticipated a substantial increase in demand after 3G licenses were granted in China, as well as the fact that our suppliers generally issued invoices several weeks to two months after the delivery of the raw materials and components, while such purchases were usually accrued in accordance with our accounting policy.

Turnover days of trade payable are derived by dividing the arithmetic mean of the beginning and ending balances of net trade and note payables for the relevant period by cost of sales and multiplying by the number of days in the period.

Our trade payable turnover days were 135 days, 143 days, 219 days and 212 days in 2006, 2007, 2008 and the eight months period ended August 31, 2009. Our payable turnover days generally remain relatively stable at 135 days in 2006 and 143 days in 2007. Our payable turnover days increased significantly from 143 days in 2007 to 219 days in 2008, due primarily to our increasing use of 90-days bank acceptance notes as a payment method, which further extended the payment period. Our trade payable turnover days decreased slightly from 219 days in 2008 to 212 days for the eight months ended August 31, 2009. See “Business — Suppliers of Raw Materials and Components” for more detailed descriptions of our payment terms.

---

## FINANCIAL INFORMATION

---

The following table sets forth our other taxes payable for the periods indicated.

	As of December 31,			As of
	2006	2007	2008	August 31, 2009
	<i>(RMB in thousands)</i>			
Value Added Tax	3,775	—	3,168	1,027
City Construction Tax and Individual Income Tax and other taxes	123	165	631	1,387
Total other taxes payable	3,898	165	3,799	2,414

The value added taxes payable by MOBI Shenzhen reflect the balance of output value added tax less balance of input value added tax. City construction tax is levied on 1% of the value added tax. Individual income tax are withheld by us to be paid on behalf of our employees.

The following table sets forth our accrued expenses for the periods indicated.

	As of December 31,			As of
	2006	2007	2008	August 31, 2009
	<i>(RMB in thousands)</i>			
Accrued engineering expenses	1,328	1,523	1,704	3,362
Accrued manufacturing expenses	782	5,143	7,463	6,360
Other accrued expenses <sup>(1)</sup>	1,346	8,502	8,083	6,793
Total accrued expenses	3,456	15,168	17,250	16,515

*Note:*

(1) Represents year-end accrual of selling and distribution, administrative and other office expenses.

Accrued expenses included expenses accrued for various manufacturing processes and audit fee. Our accrued expenses increased significantly as of December 31, 2007 from December 31, 2006 as a result of the increase in expenses associated with research, development and production activities undertaken as our sales and production increased.

### Entrusted bank loan

The interest-free entrusted loan of RMB5.0 million as of December 31, 2007 is from Shenzhen High Tech Investment and Guaranty Company Limited, a party independent from us, which entrusted loans was granted on March 22, 2007 for repayment on March 22, 2008.

### Deferred income

Deferred income represents non-recurring and non-conditional government grants received by MOBI Shenzhen and MOBI Jian in 2006, 2007, 2008 and the eight months ended August 31, 2009 from Finance Bureau of Shenzhen (深圳市財政局), Shenzhen Bureau of Trade and Industry (深圳市貿易工業局), Shenzhen Bureau of Science Technology & Information (深圳市科技和信息局), People's Government of Jian Province (吉安市人民政府) and Finance Bureau of Jian (吉安市財政局) and Shenzhen Nanshan District Bureau of Science and Technology (深圳市南山區科學技術局) respectively, for acquisition and improvement of property, plant and equipment. We have no actual knowledge of the policies and decisions behind why these government grants were made available to

---

## FINANCIAL INFORMATION

---

us. The allocation of the amount of the government grant amount may vary from period to period, and as a result, we cannot assure you that we will receive similar grants in the future, if at all. We also believe that, upon satisfaction of certain conditions including, but not limited to, being a technology company engaged in the industry sector that fits the PRC government's industrial policy, such grants may also be available to other companies.

The deferred income is released to the consolidated statements of comprehensive income over the expected useful life of the relevant assets. Movements of deferred income during the periods indicated are as follows:

	As of December 31,			As of
	2006	2007	2008	August 31,
	<i>(RMB in thousands)</i>			2009
At January 1	—	1,351	3,799	3,236
Additions	1,369	2,560	—	2,030
Realized to consolidated statements of comprehensive income	<u>(18)</u>	<u>(112)</u>	<u>(563)</u>	<u>(920)</u>
At December 31 or August 31	<u>1,351</u>	<u>3,799</u>	<u>3,236</u>	<u>4,346</u>
Analyzed for reporting purposes as:				
Current portion	54	563	563	746
Non-current portion	<u>1,297</u>	<u>3,236</u>	<u>2,673</u>	<u>3,600</u>
	<u>1,351</u>	<u>3,799</u>	<u>3,236</u>	<u>4,346</u>

### LIQUIDITY AND CAPITAL RESOURCES

#### Financial resources

We have funded our operations and capital requirements from cash generated from our operations, trade credit from our suppliers and short-term bank borrowings. Our primary uses of cash have been for our increased working capital requirements, capital expenditures on purchases of production equipment and acquisition of land use rights for our real property in Shenzhen and Jian.

The following table sets forth a condensed summary of our consolidated cash flow statements for the periods indicated. Such summary of our consolidated cash flow statements is extracted from the Accountants' Report included in Appendix I to this prospectus and you should read the entire financial statements included therein, including the notes thereto, for more details.

	As of December 31,			As of August 31,	
	2006	2007	2008	2008	2009
	<i>(unaudited)</i>				
	<i>(RMB in thousands)</i>				
Net cash from (used in) operating activities	5,494	55,382	3,347	41,231	(10,061)
Net cash used in investing activities	(31,938)	(39,684)	(56,330)	(33,908)	(46,758)
Net cash (used in) from financing activities	(209)	72,692	(19,420)	(47,003)	66,955
Net (decrease) increase in cash and cash equivalents	(26,653)	88,390	(72,403)	(39,680)	10,136
Cash and cash equivalents at beginning of year/period	69,733	43,080	131,470	131,470	59,067
Cash and cash equivalents at end of year/period	43,080	131,470	59,067	91,790	69,203

---

## FINANCIAL INFORMATION

---

### Operating Activities

Our net cash inflow/outflow from operating activities varied and is affected by: (i) our profitability, (ii) credit terms and settlement method given to us by different customers, (iii) payment method we made to suppliers, as well as (iv) level of inventory as at each reporting date. In general, credit term given by PRC domestic network operators is longer than network solution providers and overseas customers. Customer paid by bank acceptance note takes longer time for bank clearance/settlement than cash receipt. Payment we made to suppliers by bank acceptance note also allows longer time of payment than payment by direct cash remittance. Also, from time to time, our increased inventory level engaged more working capital.

In the eight months ended August 31, 2009, our net cash used in operating activities was approximately RMB10.1 million. We generated profit before taxation of approximately RMB96.9 million due primarily to an increase in sales to certain PRC network operators and network solution providers, primarily to facilitate their deployment of 3G networks; offset in part by a decrease in sales in the overseas market, as the global financial and economic crisis continued to negatively affect our overseas sales. Our trade and other receivable increased by approximately RMB151.7 million due primarily to an increase in sales to PRC domestic network operator customers who enjoy a longer credit period and our inventories increased by approximately RMB69.4 million also due primarily to our increased scale of operation. However, this increase in our cash used in operating activities was offset in part by an increase in trade and other payables due primarily to us adopting a new settlement method with our suppliers by 90-days bills payable.

In 2008, our net cash from operating activities was approximately RMB3.3 million. We generated profit before taxation of approximately RMB69.5 million due primarily to an increase in sales to certain PRC network operators, specifically, China Unicom began to increase its network build up after selling its CDMA network to China Telecom; offset in part primarily by a decrease in sales to certain overseas network operators, including Reliance in India, which we believe was reducing its capital outlay due to the global economic and financial crisis. Our trade and other payables also increased by approximately RMB99.3 million due primarily to us increasing our use of 90-days bank acceptance notes as a payment method, which has a longer payment period. However, this increase in our cash from operating activities was offset in part by an increase in inventories by approximately RMB95 million due primarily to an increase in inventory in finished goods. Our sales to overseas customers slowed down in late 2008 as a result of the global economic and financial crisis, and at the same time, we purposely increased our inventory of finished goods in products related to 3G standard in anticipation of an increased demand once the 3G licenses are granted in China. The increase in our cash from operating activities was also offset in part by a decreased in trade and other receivables by approximately RMB81.9 million due primarily to us extending a longer credit period to certain overseas customers as a result of the global economic and financial crises and an increase in sales to certain PRC domestic network operator customers in late 2008, for which we generally extended a much longer credit period than the credit period for overseas customers.

In 2007, our net cash from operating activities was approximately RMB55.4 million. We generated profit before taxation of approximately RMB59.5 million due primarily to an increase in sales to overseas customers. Our trade and other payables also increased by approximately RMB135.8 million due primarily to an increase in sales and supplier given us a longer credit period. However, this increase in our cash from operating activities was offset in part by a decrease in trade and other receivables by approximately RMB75.6 million due primarily to an increase in sales to certain overseas customers to whom we extended a shorter credit period, and a general improvement in our receivable management throughout 2007 and an increase in inventories by approximately RMB75.6 million as we increased our sales to overseas customers.

---

## FINANCIAL INFORMATION

---

In 2006, our net cash from operating activities was approximately RMB5.5 million. We generated profit before taxation of approximately RMB33.5 million due primarily to an increase in sales. Our trade and other payables increased by approximately RMB45.6 million due primarily to an increase in sales. Our inventories decreased by approximately RMB1.4 million due primarily to an increase in sales that decreased our inventory. However, this increase in our cash from operating activities was offset in part by an increase in trade and other receivable by approximately RMB81.6 million also due primarily to an increase in sales.

### Investing Activities

In the eight months ended August 31, 2009, our net cash used in investing activities was approximately RMB46.8 million, consisted primarily of an increase in pledged bank balance of approximately RMB26.9 million and payments for the purchase of property, plant and equipment of approximately RMB21.2 million. Our cash used in investing activities was offset in part primarily by a government grant for certain research and development projects of approximately RMB1.0 million.

In 2008, our net cash used in investing activities was approximately RMB56.3 million, consisted primarily of payments for the purchase of property, plant and equipment for capacity expansion of approximately RMB32.4 million, prepaid lease payments for our Xian facility of approximately RMB18.1 million and an increase in pledged bank balance of approximately RMB6.7 million.

In 2007, our net cash used in investing activities was approximately RMB39.7 million, consisted primarily of payments for the purchase of property, plant, equipment for capacity expansion of approximately RMB34.7 million and an increase in pledged bank balance of approximately RMB6.7 million. Our cash used in investing activities was offset in part by the receipt of government grants for certain research and development projects of approximately RMB0.9 million.

In 2006, our net cash used in investing activities was approximately RMB31.9 million, consisted primarily of payments for the purchase of property, plant, equipment for capacity expansion of approximately RMB40.9 million and prepaid lease payment of approximately RMB1.3 million. Our cash used in investing activities was offset in part by a decreased in pledged bank balance of approximately RMB5.5 million and the receipt of government grants for certain research and development projects of approximately RMB4.0 million.

### Financing Activities

In the eight months ended August 31, 2009, our net cash from financing activities was approximately RMB67.0 million. We had new bank loans raised of approximately RMB122.1 million and net proceeds on discounting notes receivable and trade receivables of approximately RMB12.2 million. Our cash from financing activities was offset in part by repayments of bank borrowings approximately RMB50.0 million and dividends paid of approximately RMB14.7 million.

In 2008, our net cash used in financing activities was approximately RMB19.4 million. We repaid bank borrowings by approximately RMB100.0 million, had net repaid discounting notes receivable and trade receivables of approximately RMB1.0 million and paid dividend of approximately RMB14.6 million and interest of approximately RMB3.8 million. Our cash used in financing activities was offset in part by new bank loans raised of approximately RMB100.0 million.

In 2007, our net cash from financing activities was approximately RMB72.7 million. We had new bank loans raised of approximately RMB55.0 million and net proceeds on discounting notes receivable and trade receivable of approximately RMB16.6 million and proceeds from subscription of series A preferred shares and ordinary shares of approximately RMB9.0 million. Our cash from financing activities was offset in part by repayment of bank borrowings of approximately RMB5.0 million and interest paid of approximately RMB2.9 million.

---

## FINANCIAL INFORMATION

---

In 2006, our net cash used in financing activities was approximately RMB0.2 million. We had net proceeds on discounting notes receivable and trade receivables of approximately RMB7.9 million and paid dividend paid of approximately RMB8.0 million.

### INDEBTEDNESS

Borrowings and bank facilities available to us as of December 31, 2006, 2007, 2008 and August 31, 2009 were approximately RMB37.1 million, RMB169.2 million, RMB371.9 million and RMB473.9 million, respectively. As of the close of business on October 31, 2009, being the latest practicable date for the purpose of this indebtedness statement, our unaudited net current assets increased to approximately RMB271.6 million as a result of revenue growth since August 31, 2009, and we had total bank borrowings of approximately RMB172.7 million, all of which consist of a short-term bank loans.

At the close of business on October 31, 2009, being the latest practicable date for the purpose at this indebtedness statement, we had outstanding short-term bank borrowings of approximately RMB172.7 million (of which approximately RMB48.7 million was secured by notes receivable and bank deposit). As of October 31, 2009, we have a total available banking facilities of approximately RMB466.5 million, of which approximately RMB292.3 million have been utilized. Save as aforesaid or as otherwise disclosed herein, and apart from intra-group liabilities, we did not have outstanding the close of business on October 31, 2009 any loan capital issued and outstanding or agreed to be issued, debentures, bank overdrafts, loans debt securities, borrowings or other similar indebtedness, liabilities under acceptances (other than normal trade bills) or acceptable credits, mortgages, charges, finance leases, hire purchases commitments, guarantees or other material contingent liabilities.

Subject to the completion of this Global Offering, we do not intend to raise material external debt financing. There is no material covenants relating to the outstanding bank borrowing.

Categories	As of December 31, 2006	2007	2008	As of August 31, 2009
	<i>(RMB in thousands)</i>			
Secured				
- Fixed rate	7,909	24,500	23,454	35,609
- Floating rate	—	—	—	13,135
Unsecured				
- Fixed rate	—	—	10,000	59,000
- Floating rate	—	45,000	40,000	50,000
	<u>7,909</u>	<u>69,500</u>	<u>73,454</u>	<u>157,744</u>

Short-term bank borrowings are arranged at fixed rates as well as floating rates.

The short-term secured floating rate bank borrowings are denominated in U.S. dollars and carry at prevailing market interest rates of 1.39% per annum as of August 31, 2009. The short-term secured fixed rate bank borrowings are denominated in RMB and carry fixed interest rates ranging from 1.39% to 7.67% per annum during 2006, 2007, 2008 and eight months ended August 31, 2009. The short-term secured bank borrowing as of August 31, 2009 are secured by notes receivable and bank deposit of approximately RMB48.7 million (December 31, 2008: by notes receivable of approximately RMB23.5 million, December 31, 2007: by receivables of approximately RMB24.5 million, December 31, 2006: by notes receivable of approximately RMB7.9 million). The related trade and note receivables were discounted with recourse and therefore, they have not been derecognised at December 31, 2006, 2007 and 2008 and August 31, 2009.

---

## FINANCIAL INFORMATION

---

The short-term unsecured floating rate bank borrowings are denominated in RMB and carry at prevailing market interest rates linked to The People's Bank of China Benchmark Interest Rate ("PBOC Rate") of 4.62% to 7.47% per annum during 2006, 2007, 2008 and eight months ended August 31, 2009. The short-term unsecured fixed rate bank borrowings are denominated in RMB and carry fixed interest rates ranging from 4.62% to 6.12% per annum during 2006, 2007, 2008 and eight months ended August 31, 2009.

We have not had difficulties renewing our facilities in the past. We have obtained confirmation from our banks which granted us facilities with expiry dates prior to end of February 2010 in respect of rolling over these facilities for 2010. We believe our funding requirements in the foreseeable future can be met by undrawn banking facilities.

### Operating lease arrangement

At the end of each reporting period, we were committed to make the following future minimum lease payments in respect of rented premises under non-cancellable operating leases which fall due as follows:

	As of December 31,			As of
	2006	2007	2008	August 31, 2009
	<i>(RMB in thousands)</i>			
Within one year	5,223	4,152	5,031	9,403
In the second to fifth year (inclusive)	<u>5,170</u>	<u>3,463</u>	<u>1,848</u>	<u>26,657</u>
	<u>10,393</u>	<u>7,615</u>	<u>6,879</u>	<u>36,060</u>

The leases are generally negotiated for terms ranging from one to six years and rentals are fixed for an average of three years.

### Capital commitments

The following table presents our capital commitments as of the dates indicated.

	For the Year Ended		For the Eight	
	December 31,		Months Ended	
	2006	2007	2008	August 31, 2009
	<i>(RMB in thousands)</i>			
Capital expenditure contracted for but not provided in respect of the acquisition of property, plant and equipment	<u>2,681</u>	<u>3,703</u>	<u>3,310</u>	<u>2,459</u>

### Off-balance sheet arrangements

As of the close of business on August 31, 2009, we did not have any outstanding derivative financial instruments, off-balance sheet guarantees, interest rate swap transactions or foreign currency forward contracts.

---

## FINANCIAL INFORMATION

---

### Working capital

We have historically financed our operations through cash from operating activities, bank borrowings and private placement of ordinary and preferred shares. In the future, we expect to use funds from a combination of sources to fund our operation and expansion plan, including bank loans, internally generated cash flow, and proceeds from the Global Offering.

Taking into account the financial resources available to us including internally generated funds, available banking facilities and the estimated net proceeds of the Global Offering, the Directors are of the opinion that we have sufficient working capital to meet our present requirements, and at least for the period ending 12 months from the date of this prospectus.

### MARKET RISKS

Our business and result of operations are affected by economic cycles, including the recent global financial and economic crisis. Since the second half of 2008, the global financial system has experienced significant difficulties and disruptions, leading to reduced liquidity, greater volatility, widened credit spreads and a lack of price transparency in the global credit and financial markets. The difficulties in global credit and financial markets have also resulted in a widening global economic crisis. There are indications that the current financial and economic downturn may persist or worsen. The slowdown experienced in the economies of the United States, the European Union and certain Asian countries adversely affected capital expenditures of the network providers in different countries, which inevitably affect the demand of our products. The decrease and slowdown in demand for mobile communication infrastructure equipment resulted from the global financial and economic crisis has put significant downward pressure on prices of antenna system and base station RF subsystem products, which are our major source of sales revenues. Nonetheless, we will continue monitoring the latest development in these markets through our international sales team or independent distributors for opportunities to ramp up sales with our existing customers and to develop new customer relationships. Apart from the inherent risks of the economy, we are also exposed to credit, currency and interest rate risks in the normal course of our business.

### Credit risk

Our credit risk is primarily attributable to our trade receivables. The credit risk on trade receivables is concentrated on the trade receivables from top five customers which attributable to a significant portion of our trade receivables. For certain of our customers, we have longer payment terms that result in long accounts receivable cycle. See “Business — Sales and Marketing”. In order to minimize the credit risk, our management has delegated a team of at least four members, depending on the customer account, headed by our vice president in Sales and Marketing, to be responsible for determination of credit limits, credit approvals and other monitoring procedures to ensure that follow-up action is taken to recover overdue debts. We review the recoverable amount of each individual trade debtor at the end of each reporting period date to ensure that adequate impairment losses are made for irrecoverable amounts. In this regard our Directors consider our credit risk to be significantly reduced.

### Currency Risk

We have foreign currency sales and purchases and certain trade receivables and bank balances of ours are denominated in United States dollar, Euro (“EUR”) and Hong Kong dollar, currencies other than the functional currency of the respective group entities, which expose the Group to foreign currency risk. Our bank balances are denominated in US\$ and HK\$. We currently do not have a foreign currency hedging policy. However, the management monitors foreign exchange exposure and will consider hedging significant foreign currency exposure when the need arises.

## FINANCIAL INFORMATION

The carrying amount of the foreign currency denominated monetary assets and monetary liabilities at the end of each reporting period are as follows:

	2006		As of December 31, 2007		2008		As of August 31, 2009	
	Assets	Liabilities	Assets	Liabilities	Assets	Liabilities	Assets	Liabilities
<i>(RMB in thousands)</i>								
The Group								
US\$	33,045	—	73,737	6,343	40,948	6,343	25,528	19,478
EUR	—	—	31,371	—	13,118	—	9,654	—
HK\$	68	—	15	290	5	290	217	290
The Company								
US\$	16,543	—	11,960	6,343	9,674	6,343	8,504	6,343
HK\$	50	—	—	290	1	290	214	290

The following table details the sensitivity to a 5% change in the RMB against US\$, EUR and HK\$. The 5% is the rate used when reporting currency risk internally to key management personnel and represents management's assessment of the reasonably possible change in the foreign exchange rates. The sensitivity analyses of our exposure to foreign currency risk at the end of each reporting period have been determined based on the adjustment of translation of the monetary assets and liabilities at the end of each reporting period for a 5% change in foreign currency rates. A positive or negative number indicates an increase or a decrease in the post-tax profit/a decrease or an increase in post-tax loss where RMB strengthens against US\$, EUR and HK\$. For a 5% weakening of RMB against US\$, EUR and HK\$, there would be an equal and opposite impact of the post-tax profit or loss.

	For the Year Ended December 31,			For the Eight Months Ended August 31,	
	2006	2007	2008	2008	2009
<i>(unaudited)</i>					
<i>(RMB in thousands)</i>					
The Group					
Increase (decrease) in post-tax profit <sup>(1)</sup>					
If RMB strengthens against US\$	(1,404)	(2,862)	(1,443)	(1,317)	(259)
If RMB strengthens against EUR	—	(1,333)	(558)	(1,102)	(410)
If RMB strengthens against HK\$	(3)	11	12	10	3
The Company					
Increase (decrease) in post-tax profit or (increase) decrease in post-tax loss					
If RMB strengthens against US\$	(703)	(239)	(114)	(155)	(89)
If RMB strengthens against HK\$	(2)	12	12	10	3

Note:

- (1) This is mainly attributable to the outstanding foreign currency receivables and bank balances at year end as a result of our foreign currency sales.

---

## FINANCIAL INFORMATION

---

In management's opinion, the sensitivity analysis is unrepresentative of the inherent foreign exchange risk as the exposure at the end of each reporting period does not reflect the exposure during each of the respective reporting period.

### Interest Rate Risk

We are exposed to fair value interest rate risk which arose from pledged bank balance, bank balances, entrusted bank loan and fixed rate bank borrowings. Our interest bearing pledged bank balance and bank balances are mainly short-term nature. We are also exposed to cash flow interest rate risk in relation to bank balances and variable-rate bank borrowings. Our cash flow interest rate risk is mainly concentrated on the fluctuation of the PBOC Rate arising from our RMB denominated borrowings. Therefore, any future variations in interest rates are not likely to have a significant impact on our results of operations. We currently have not implemented any interest rate hedging policy. However, our management monitors interest rate exposure and will consider repaying bank loans when significant interest rate exposure is anticipated.

### TAXATION AND ESTATE DUTY

Our Company was incorporated in the Cayman Islands and is not subject to the income tax in the Cayman Islands.

MOBI Shenzhen was established in Shenzhen, PRC on August 12, 1999. In accordance with the tax legislations applicable to MOBI Shenzhen at the time, it was entitled to exemption from PRC enterprise income tax for the two years commencing from its first profit making year of operations, after offsetting all unexpired tax losses carried forward from previous years, and thereafter, entitled to a 50% relief from PRC enterprise income tax of 15% for the next three years. The first year for which MOBI Shenzhen recorded profit for PRC tax purpose was the year ended December 31, 2000. Accordingly, the applicable tax rate for MOBI Shenzhen was 7.5% for the year ended December 31, 2006 and 2007. On December 16, 2008, MOBI Shenzhen was recognized as a high technology company by Shenzhen Science and Technology Bureau, Shenzhen Finance Bureau, Administrator of Local Taxation of Shenzhen Municipality and Shenzhen Municipal office of the State Administration of Taxation, which entitled it to 15% preferential tax rate from PRC enterprise income tax for the next three years starting from 2008. Accordingly, the applicable tax rate for MOBI Shenzhen was 15% for the year ended December 31, 2008 and for the eight months ended August 31, 2009.

The applicable tax rate of MOBI Jian was 33% before year 2007, and according to the New PRC Enterprise Income Tax Law, the applicable tax rate was decreased to 25% starting from January 1, 2008. In accordance with the tax legislations applicable to MOBI Jian, it was entitled to exemption from PRC enterprise income tax for the two years commencing from its first profit making year of operations, after offsetting all unexpired tax losses carried forward from previous years, and thereafter, entitled to a 50% relief from PRC enterprise income tax of 25% for the next three years. Accordingly, the tax rate for MOBI Jian was nil for the period from May 23, 2006 (date of establishment) to December 31, 2006, and 2007, and 12.5% for the year ended December 31, 2008 and for the eight months ended August 31, 2009.

The applicable tax rate of MOBI Xian is 25% for the period from April 28, 2008 (date of establishment) to December 31, 2008 and for the eight months ended August 31, 2009.

On March 16, 2007, the PRC promulgated the Law of the People's Republic of China on Enterprise Income Tax by Order No. 63 of the President of the People's Republic of China (the "New PRC Enterprise Income Tax Law"), which became effective on January 1, 2008. On December 6, 2007, the State Council issued Implementation Regulations of the New PRC Enterprise Income Tax Law. According to the New PRC Enterprise Income Tax Law, the Implementation Regulations and other relevant interpretative documents, the following transitional tax policies are applicable to our PRC subsidiaries in lieu of the former preferential income tax rate before the taking effect of the New PRC Enterprise Income Tax Law: the preferential income tax rate of 15% applicable to any enterprise before the taking effect of the New PRC Enterprise Income Tax Law will be increased to 25% on a gradual basis over five years starting from year 2008, which means that the income tax rate will be

---

## FINANCIAL INFORMATION

---

18%, 20%, 22%, 24% and 25% from year 2008 to year 2012 respectively. As for those enterprises which enjoy the preferential tax treatment that their income tax will be exempted for the first two years starting from its first profit making year of operations, and for the following three years, their income tax payable will be halved, they are entitled to continue to enjoy the aforesaid preferential tax treatment after January 1, 2008 until the expiration of the same. However, if any of the said enterprises has not yet enjoyed the aforesaid preferential tax treatment due to the fact that it has not yet making profits, the term of the aforesaid preferential tax treatment applicable to such enterprise shall be commenced from year 2008. In addition, in case there is overlapping between the aforesaid transitional tax policies and the relevant preferential tax policies set forth in the New PRC Enterprise Income Tax Law and the Implementation Regulations, the enterprises shall have the discretion to choose the most favorable tax policies to be applicable to them. MOBI Shenzhen and MOBI Jian are the only two PRC Subsidiaries that currently enjoy certain tax exemption and reduction treatment, among which MOBI Shenzhen has chosen the preferential income tax rate of 15% applicable to high new technology companies in accordance with the New PRC Enterprise Income Tax Law, and MOBI Jian still enjoys the preferential tax treatment that its income tax payable is halved for the term of three years. Both of the aforesaid two subsidiaries are entitled to continue to enjoy the preferential tax treatment until the expiration of the same. On the other hand, MOBI Xian adopted a unified income tax rate of 25% according to the New PRC Enterprise Income Tax Law and does not enjoy any preferential tax treatment.

### INFLATION

Inflation in China has not materially impacted our results of operations over 2006, 2007, 2008 and the eight months ended August 31, 2009. According to the National Bureau of Statistics of China, inflation as measured by the increase in the consumer price index in China was 1.5%, 4.8% and 5.9% in 2006, 2007 and 2008, respectively.

### PROPERTY INTERESTS

Details relating to our property interests are set out in Appendix IV to this prospectus. Savills Valuation and Professional Services Limited, an independent property valuation firm, has valued the properties owned and leased by us as of September 30, 2009. The text of their letters, summaries of values and valuation certificates are set out in Appendix IV to this prospectus.

A reconciliation of the net book value of the relevant leasehold buildings and prepaid lease payments as at August 31, 2009 to their fair value as stated in appendix IV to this prospectus is as follows:

	<i>(RMB in thousands)</i>
Net book value at August 31, 2009	
— Leasehold buildings and prepaid lease payments	76,190
Depreciation/amortisation for the month ended September 30, 2009	<u>(186)</u>
Net book value at September 30, 2009	76,004
Valuation surplus	<u>63,296</u>
Valuation amount at September 30, 2009 <sup>(1)</sup>	<u><u>139,300</u></u>

*Note:*

1. The valuation amount includes estimated capital values of the properties numbered 1, 2 and 3 in the Property Valuation Report while an estimated capital value of RMB98,500,000 is assumed for the property numbered 1 in the Property Valuation Report based on certain assumptions, the details of which are set out in the relevant valuation certificate in the Property Valuation Report.

---

## FINANCIAL INFORMATION

---

### PROFIT FORECAST FOR THE YEAR ENDING DECEMBER 31, 2009

All statistics in this table are based on the assumption that the Over-allotment Option is not exercised.

Forecast consolidated profit attributable to owners of the Company<sup>(1)</sup> .....Not less than RMB101.7 million  
(equivalent to approximately HK\$115.9 million)

Unaudited pro forma forecast basic earnings per Share<sup>(2)</sup> .....Not less than RMB0.14  
(equivalent to approximately HK\$0.16)

---

*Notes:*

- The bases and principal assumptions on which the forecast consolidated profit attributable to owners of the Company for the year ending December 31, 2009 are extracted from the section headed "Profit Forecast" in Appendix III of the prospectus. The bases on which the above profit forecast for the year ending December 31, 2009 have been prepared are summarized in the section headed "Profit Forecast" in Appendix III to the prospectus and assuming the translation of Hong Kong dollars to Renminbi with the exchange rate at RMB1.00 to HK\$1.14.
- The calculation of the unaudited pro forma forecast basic earnings per Share is based on the forecast consolidated profit attributable to owners of the Company for the year ending December 31, 2009 assuming that the Global Offering had occurred on January 1, 2009 and a total of 702,057,995 Shares had been in issue during the year, but does not take into account any Shares which may be issued upon the exercise of the Over-allotment Option and assuming the translation of Hong Kong dollars to Renminbi with the exchange rate at RMB1.00 to HK\$1.14.

### UNAUDITED PRO FORMA FINANCIAL INFORMATION

The following statement of our unaudited pro forma adjusted net tangible assets is based on the audited consolidated net tangible assets of our Group as of August 31, 2009, as shown in the Accountants' Report, the text of which is set out in Appendix I to this prospectus, and adjusted as follows:

	<b>Audited consolidated net tangible assets attributable to owners of the Company as of August 31, 2009<sup>(1)</sup></b>	<b>Estimated net proceeds from the issue of Offer Shares<sup>(2)</sup> (RMB in thousands)</b>	<b>Unaudited pro forma adjusted net tangible assets<sup>(3)</sup></b>	<b>Unaudited pro forma adjusted net tangible assets per Share<sup>(4)</sup> (RMB)</b>	<b>Unaudited pro forma adjusted net tangible asset per Share (HK\$)<sup>(4)</sup></b>
Based on Offer Price of HK\$2.72 per share	397,272	389,262	786,534	1.12	1.28
Based on Offer Price of HK\$3.50 per share	397,272	506,038	903,310	1.29	1.47

---

*Notes:*

- As of August 31, 2009, our audited consolidated net tangible assets attributable to owners of our Company was equal to equity attributable to owners of our Company extracted from the Accountants' Report set out in Appendix I to this prospectus.

---

## FINANCIAL INFORMATION

---

- (2) The estimated net proceeds from the Global Offering are based on the Offer Price of HK\$2.72 and HK\$3.50 per Offer Share, respectively, after deduction of the underwriting fees and other related expenses payable by us and assuming the translation of Hong Kong dollars to Renminbi with the exchange rate at RMB1.00 to HK\$1.14. No account has been taken on the Shares which may be issued pursuant to any exercise of the Over-allotment Option and assuming the translation of Hong Kong dollars to Renminbi with the exchange rate at RMB1.00 to HK\$1.14.
- (3) By comparing the valuation of our property interests (including an estimated capital value of RMB98,500,000 for property numbered 1 in Appendix IV based on certain assumptions set out in the valuation certificate therein) as of September 30, 2009 as set out in Appendix IV to this prospectus and the unaudited net book value of these properties as of September 30, 2009, the valuation surplus was approximately RMB63.3 million, which has not been included in the above net tangible assets. The valuation surplus of our property interests will not be incorporated in our future financial statements. If the valuation surplus were to be included in our future financial statements, an additional depreciation charge of approximately RMB1.3 million per annum would be incurred.
- (4) The unaudited pro forma adjusted net tangible assets per Share is based on a total of 702,057,995 Shares expected to be in issue immediately after the completion of the Global Offering (assuming no exercise of the Over-allotment Option) and assuming the translation of Hong Kong dollars to Renminbi with the exchange rate at RMB1.00 to HK\$1.14.

### EARNINGS PER SHARE

Basic earnings per Share of 7.91 cents, 15.21 cents, 15.41 cents, 8.83 cents and 21.38 cents for the year ended December 31, 2006, 2007, 2008 and the eight months ended August 31, 2008 and 2009, respectively, are calculated by reference to the earnings of RMB29.5 million, RMB56.8 million, RMB57.6 million, RMB33.0 million and RMB79.8 million in each of the respective periods and weighted average number of Shares of 372,500,000, 373,232,000, 373,543,000, 373,543,000 and 373,543,000 in each of the respective periods.

Diluted earnings per Share of 5.99 cents, 10.62 cents, 11.60 cents, 6.93 cents and 15.50 cents for the year ended December 31, 2006, 2007, 2008 and the eight months ended August 31, 2008 and 2009, respectively, are calculated by reference to the earnings of RMB31.5 million, RMB56.8 million, RMB61.9 million, RMB37.3 million and RMB84.2 million in each of the respective periods and weighted average number of Shares of 525,445,000, 534,405,000, 533,954,000, 538,789,000, and 543,140,000 in each of the respective periods.

### DIVIDENDS

Dividend of RMB0.07965 per share was proposed and paid during the year ended December 31, 2006 to each ordinary share and Series A Preferred Share and amounted to approximately RMB5.9 million and RMB2.0 million respectively. Dividend of RMB0.1424 per share was proposed and paid during the year ended December 31, 2008 to each ordinary share and Series A Preferred Share and amounted to approximately RMB10.6 million and RMB4.4 million respectively. The dividends were paid out in cash and out of distributable profits of our Company.

### DIVIDEND POLICY

We currently do not have a dividend policy. The declaration, payment and amount of dividends in the future will be subject to the discretion of the Board and will depend on our results of operations, cash flows, financial condition, statutory and regulatory restrictions on the payment of dividends by us, future prospects and other factors that our Directors may consider relevant. Holders of our Shares will be entitled to receive such dividends pro rata according to the amounts paid up or credited as paid up on the Shares. The declaration, payment, and amount of dividends will be subject to the discretion of the Directors.

Dividends may be paid only out of our distributable profits as permitted under the relevant laws. To the extent profits are distributed as dividends, such portion of profits will not be available to be reinvested in our operations. There can be no assurance that our Company will be able to declare or distribute any dividend in the amount set out in any plan of the Board or at all. The dividend distribution record in the past may not be used as a reference or basis to determine the level of dividends that may be declared or paid by us in the future.

---

## **FINANCIAL INFORMATION**

---

### **DISTRIBUTABLE AND STATUTORY RESERVE**

MOBI Shenzhen and MOBI Jian are subject to the requirement on accruing statutory reserve in accordance with applicable laws and regulations in the PRC. According to relevant PRC laws, wholly foreign owned companies in the PRC are required to accrue at least 10% of their net profit after taxation, as determined under the PRC accounting regulation. Our Company is exempted from the accrual request after its accumulative reserve reaches 50% of the registered capital. The accrual of this reserve must be made before the distribution of a dividend to equity owners. The reserve can be used to make up for previous year's losses, if any. The reserve must be accrued before distributing dividends by MOBI Shenzhen and MOBI Jian.

### **DISCLOSURE UNDER THE LISTING RULES**

Our Directors have confirmed that there are no circumstances which, had we been required to comply with Rules 13.13 to 13.19 of the Listing Rules, would give rise to a disclosure requirement under Rules 13.13 to 13.19 of the Listing Rules.

### **NO MATERIAL ADVERSE CHANGE**

Our Directors confirm that there has been no material adverse change in the financial or trading position, indebtedness, mortgage, contingent liabilities, guarantees or prospects of our Group since August 31, 2009, the date to which the latest audited financial statements of our Group were made up.

---

## FUTURE PLANS AND USE OF PROCEEDS

---

### FUTURE PLANS

We are currently constructing our major manufacturing facility located in Jizhou Industrial Zone, Jian City, Jiangxi Province and our manufacturing and research and development facility in Xian, Shaanxi Province. The estimated capital expenditure for each of the Jian and Xian facilities (including purchases of machinery and equipment) for the three years ending December 31, 2012 are RMB61.0 million and RMB32.0 million, respectively. Please see “Business — Our Strategy” for a more detailed description of our future plans.

### USE OF PROCEEDS

We estimate that the aggregate net proceeds to us from the Global Offering (after deducting underwriting fees and estimated expenses payable by us in connection with the Global Offering and assuming an Offer Price of HK\$3.11 per Share, being the mid-point of the indicative range of the Offer Price of HK\$2.72 to HK\$3.50 per Share, and assuming the Over-allotment Option is not exercised) will be approximately HK\$510.3 million.

The principal purposes of our Global Offering are to:

- Create a public market for our ordinary shares for the benefit of all of our shareholders;
- Attract and retain high caliber employees by share options granted and to be granted; and
- Raise funds for the purposes described as follows.

We expect to spend much of the proceeds of the Global Offering to achieve our primary objectives as follows:

**1. Expansion of manufacturing capacity:**

In order to satisfy the increasing demand from our customers in China and overseas, we intend to use approximately HK\$153.1 million, representing approximately 30% of our net proceeds from the Global Offering, to finance further expansion of our manufacturing capacity, including without limitation, the construction of facilities in Jian and Xian, for which we expect to spend approximately RMB68.0 million, RMB6.5 million and RMB18.5 million in the year ending December 31, 2010, 2011 and 2012, respectively.

**2. Merger and acquisition reserve:**

Although we have not identified any specific target, we intend to reserve approximately HK\$229.6 million, representing approximately 45% of our net proceeds from the Global Offering, for future acquisition of companies, businesses, assets or teams for the purpose of enhancing our position in China and overseas markets, including, without limitation:

- Expanding our product portfolio in wireless communication devices in order to maximize 3G opportunities in China and the growing demand from our international customers;
- Expanding our presence in the overseas network operator market; and
- Expanding our manufacturing capacity and sales network.

In the absence of suitable acquisition target, we intend to invest such reserved proceeds to pursue internal growth including, but not limited to, building facilities for research and development, manufacturing and storage, purchasing land, plant and equipment, establishing overseas sales offices and recruiting more staff.

---

## FUTURE PLANS AND USE OF PROCEEDS

---

### 3. **Research and development on strategic products and technologies:**

We intend to use approximately HK\$76.6 million, representing approximately 15% of our net proceeds from the Global Offering, to finance our research and development efforts in products, technologies and manufacturing capacity. We will continue to enhance our technology and develop more new products for the TD-SCDMA, CDMA2000, W-CDMA, GSM, CDMA and LTE (Long Term Evolution) in the next generation of standards and protocols.

### 4. **General corporate purposes:**

We intend to use approximately HK\$51.0 million, representing approximately 10% of our net proceeds from the Global Offering, for general corporate purposes, including increasing our working capital as we expand.

In the event that the Offer Price is set at the high-end of the proposed Offer Price range, we will receive net proceeds of approximately HK\$576.9 million. The additional net proceeds of about HK\$66.6 million (when compared to the net proceeds with the Offer Price being determined at the mid-point of the stated range) will be allocated pro rata as if the Offer Price is set at the mid-point of the stated range of the Offer Price.

In the event that the Offer Price is set at the low-end of the proposed Offer Price range, we will receive net proceeds of approximately HK\$443.8 million. Under such circumstances, the net proceeds will be allocated pro rata as if the Offer Price is set at the mid-point of the stated range of the Offer Price.

---

## UNDERWRITING

---

### UNDERWRITERS

#### Hong Kong Underwriters

Piper Jaffray Asia Securities Limited  
First Shanghai Securities Limited  
Taifook Securities Company Limited

#### International Underwriters

Piper Jaffray Asia Securities Limited  
First Shanghai Securities Limited  
China Merchants Securities (HK) Co., Limited  
CIMB Securities (HK) Limited  
TSC Capital Limited

### UNDERWRITING ARRANGEMENTS AND EXPENSES

#### (a) Hong Kong Public Offering

##### *Hong Kong Underwriting Agreement*

The Hong Kong Underwriting Agreement was entered into on December 3, 2009. Pursuant to the Hong Kong Underwriting Agreement, our Company is offering initially 17,552,000 Hong Kong Offer Shares (subject to adjustment) for subscription by the public in Hong Kong at the Offer Price on and subject to the terms and conditions of this prospectus and the Application Forms.

Subject to the Listing Committee of the Stock Exchange granting approval of the listing of, and permission to deal in, the Shares in issue, the Shares which fall to be issued pursuant to the Capitalization Issue, the Offer Shares (including any Shares which may be issued or sold under the Over-allotment Option), the Shares to be issued upon conversion of the Series A Preferred Shares and any Shares which may be issued pursuant to the exercise of the Pre-IPO Options and the options granted under the Share Option Scheme and to certain other conditions set out in the Hong Kong Underwriting Agreement, the Hong Kong Underwriters have severally agreed to subscribe or procure subscribers for their respective applicable proportions of the Hong Kong Offer Shares now being offered which are not taken up under the Hong Kong Public Offering on the terms and subject to the conditions of this prospectus, the Application Forms and the Hong Kong Underwriting Agreement.

The Hong Kong Underwriting Agreement is conditional upon and subject to the International Underwriting Agreement having been signed and becoming unconditional.

##### *Grounds for Termination*

The obligations of the Hong Kong Underwriters to subscribe or procure subscribers for the Hong Kong Offer Shares under the Hong Kong Underwriting Agreement are subject to termination, upon the giving of notice in writing by Global Coordinator (for itself and on behalf of the Hong Kong Underwriters) to our Company if, at any time prior to 8:00 a.m. on the Listing Date (“Termination Time”):

- (A) there comes to the notice of the Global Coordinator or the Hong Kong Underwriters:
  - (1) any matter or event showing any of the representations, warranties or undertakings contained in the Hong Kong Underwriting Agreement to be untrue, inaccurate or misleading in any respect when given or repeated or there has been a breach of any of the representations, warranties or undertakings contained in the Hong Kong Underwriting Agreement or any other provisions of the Hong Kong Underwriting Agreement by any party thereto other than the Hong Kong Underwriters which, in any such cases, is considered, in the sole objective opinion of the Global Coordinator, to be material in the context of the Hong Kong Public Offering; or

---

## UNDERWRITING

---

- (2) any statement contained in this prospectus, the Application Forms, the formal notice and any announcements in the agreed form issued by the Company in connection with the Hong Kong Public Offering (including any supplement or amendment thereto) has become or been discovered to be untrue, incorrect or misleading in any respect and is considered in the sole objective opinion of the Global Coordinator to be material; or
  - (3) any event, series of events, matter or circumstance occurs or arises on or after the date of the Hong Kong Underwriting Agreement and before the Termination Time, being event, matter or circumstance which, if it had occurred before the date of the Hong Kong Underwriting Agreement, would have rendered any of the representations, warranties or undertakings contained in the Hong Kong Underwriting Agreement untrue, incorrect or misleading in any respect, and which is considered, in the sole objective opinion of the Global Coordinator to be material in the context of the Global Offering; or
  - (4) any matter which, had it arisen or been discovered immediately before the date of this prospectus and not having been disclosed in this prospectus, would have constituted, in the sole objective opinion of the Global Coordinator, a material omission in the context of the Global Offering; or
  - (5) any event, act or omission which gives or is likely to give rise to any material liability of the Company and the covenantors of the Hong Kong Underwriting Agreement arising out of or in connection with any of the representations, warranties or undertakings contained in the Hong Kong Underwriting Agreement; or
  - (6) any breach by any party to the Hong Kong Underwriting Agreement other than the Global Coordinator and the Hong Kong Underwriters of any provision of Hong Kong Underwriting Agreement which, in the sole opinion of the Global Coordinator, is material; or
- (B) there shall have developed, occurred, existed, or come into effect any event or series of events, matters or circumstances whether occurring or continuing before, on and/or after the date of the Hong Kong Underwriting Agreement and including an event or change in relation to or a development of an existing state of affairs concerning or relating to any of the following:
- (1) any new law or regulation or any change in existing laws or regulations or any change in the interpretation or application thereof by any court or other competent authority in Hong Kong, the Cayman Islands, the PRC or any of the jurisdictions in which the Group operates or has or is deemed by any applicable law to have a presence (by whatever name called) or any other jurisdiction relevant to the Group; or
  - (2) any change in, or any event or series of events or development resulting or likely to result in any change in Hong Kong, the Cayman Islands, the PRC or any of the jurisdictions in which the Group operates or has or is deemed by any applicable law to have a presence (by whatever name called) or any other jurisdiction relevant to the Group, the local, regional or international financial, currency, political, military, industrial, economic, stock market or other market conditions or prospects; or
  - (3) any change in the conditions of the U.S., Hong Kong, the PRC or international equity securities or other financial markets; or

---

## UNDERWRITING

---

- (4) the imposition of any moratorium, suspension or restriction on trading in securities generally on any of the markets operated by the Stock Exchange due to exceptional financial circumstances or otherwise; or
- (5) any change or development involving a prospective change in all forms of taxation or exchange control (or the implementation of any exchange control) in Hong Kong, the Cayman Islands, the PRC or any of the jurisdictions in which the Group operates or has or is deemed by any applicable law to have a presence (by whatever name called) or any other jurisdiction relevant to the Group; or
- (6) any change or prospective change in the business or in the financial or trading position or prospects of any member of the Group; or
- (7) the imposition of economic sanction or withdrawal of trading privileges, in whatever form, by the U.S. or by the European Union (or any member thereof) on Hong Kong or the PRC; or
- (8) a general moratorium on commercial banking activities in the PRC or Hong Kong declared by the relevant authorities; or
- (9) any event of force majeure including, without limiting the generality thereof, any act of God, military action, riot, public disorder, civil commotion, tsunami, fire, flood, explosion, terrorism (whether or not responsibility has been claimed), strike or lock-out epidemic, outbreak of diseases and epidemic (including but not limited to H1N1 flu, severe acute respiratory syndrome and H5N1 and other related or mutated forms);
- (10) any litigation or claim of material importance of any third party being instigated against any member of the Group;

which, in the sole objective opinion of the Global Coordinator:

- (i) is or will be, or is very likely to be, adverse, in any material respect, to the business, financial or other condition or prospects of the Group; or
- (ii) has or will have or is very likely to have an adverse effect on the success of the Global Offering or the level of the Offer Shares being applied for or accepted, the distribution of the Offer Shares or the demand or market price of the Shares following the Listing; or
- (iii) for any other reason makes it impracticable, inadvisable or inexpedient for the Hong Kong Underwriters to proceed with the Hong Kong Public Offering as a whole.

For the above purpose:

- (1) a change in the system under which the value of the Hong Kong currency is linked to that of the currency of the U.S. or a devaluation of the Renminbi against any foreign currencies shall be taken as an event resulting in a change in currency conditions; and
- (2) any normal market fluctuations shall not be construed as events or series of events affecting market conditions referred to above.

Similar events are contained in the International Underwriting Agreement that may allow the International Underwriters to terminate their respective obligations thereunder.

---

## UNDERWRITING

---

### (b) **International Placing**

#### *International Underwriting Agreement*

In connection with the International Placing, it is expected that we will, on or about Price Determination Date, enter into the International Underwriting Agreement with, among others, the International Underwriters. Under the International Underwriting Agreement, the International Underwriters would, subject to certain conditions set out therein, agree to subscribe for the International Placing Shares being offered pursuant to the International Placing or procure subscribers to subscribe for such International Placing Shares.

Under the International Underwriting Agreement, we are expected to grant to the International Underwriters the Over-allotment Option, exercisable by the Global Coordinator on behalf of the International Underwriters at any time from the date of the International Underwriting Agreement up to (and including) January 8, 2009, being the 30th day after the last day for the lodging of applications under the Hong Kong Public Offering, to require us to allot and issue up to an aggregate of 26,327,000 additional Shares, representing in aggregate not more than 15% of the maximum number of Offer Shares initially available under the Global Offering.

### **UNDERTAKINGS GIVEN TO THE STOCK EXCHANGE PURSUANT TO THE LISTING RULES**

#### **By Us**

Pursuant to Rule 10.08 of the Listing Rules, we have undertaken to the Stock Exchange that except pursuant to the Global Offering, the conversion of the Series A Preferred Shares, the Capitalization Issue, the exercise of the Over-allotment Option, the exercise of the Pre-IPO Options and the exercise of any options that may be granted under the Share Option Scheme as described in the paragraph headed “Share Option Scheme” in Appendix VI to this prospectus, no further Shares or securities convertible into equity securities of the Company (whether or not of a class already listed) will be issued by us or form the subject of any agreement to such an issue by our Company within six months from the Listing Date (whether or not such issue of Shares or securities of our Company will be completed within six months from the Listing Date), except in certain circumstances prescribed by Rule 10.08 of the Listing Rules.

#### **By Fangyi Holdings and the Beneficial Owners**

Pursuant to Rule 10.07(1) of the Listing Rules, each of Fangyi Holdings, Junyi Holdings, Hou Weigui, Hu Xiang, the Beneficial Owners, Wang Guoying and Shao Zhiguo has undertaken to the Stock Exchange, us, the Joint Sponsors and the Global Coordinator (for itself and on behalf of the Underwriters) that, except pursuant to the Global Offering or the Over-allotment Option, it, he or she shall not and shall procure that its, his or her associates or companies controlled by it, him or her or nominees or trustees (as the case may be) in whose name the Shares are registered (the “Relevant Registered Holders”) shall not:

- (a) in the period commencing on the date of this prospectus and ending on the date which is six months from the Listing Date dispose of, nor enter into any agreement to dispose of or otherwise create any options, rights, interests or encumbrances in respect of, any of the Shares in respect of which it, he or she is shown by this prospectus to be the beneficial owner (whether direct or indirect); and
- (b) in the period of six months commencing on the date on which the period referred to in (a) above expires, dispose of, nor enter into any agreement to dispose of or otherwise create any options, rights, interests or encumbrances in respect of, any of the Shares referred to in (a) above if, immediately following such disposal or upon the exercise or enforcement

---

## UNDERWRITING

---

of such options, rights, interests or encumbrances, Fangyi Holdings, Junyi Holdings, Hou Weigui, Hu Xiang, the Beneficial Owners, Wang Guoying and Shao Zhiguo collectively would cease to be the controlling shareholder (as defined in the Listing Rules) of Our Company.

Each of Fangyi Holdings, Junyi Holdings, Hou Weigui, Hu Xiang, the Beneficial Owners, Wang Guoying and Shao Zhiguo has also undertaken to the Stock Exchange, us, the Joint Sponsors and the Global Coordinator (for itself and on behalf of the Underwriters) that, within the period commencing on the date of this prospectus and ending on the date which is 12 months from the Listing Date, it, he or she will:

- (a) when it, he or she (or through the Relevant Registered Holder(s)) pledges or charges any Shares beneficially owned by it, him or her in favour of an authorized institution (as defined in the Banking Ordinance (Chapter 155 of the Laws of Hong Kong)) for a bona fide commercial loan, immediately inform us in writing of such pledge or charge together with the number of Shares so pledged or charged; and
- (b) when it, he or she receives indications, either verbal or written, from the pledgee or chargee that any of the pledged or charged Shares will be disposed of, immediately inform us in writing of such indications.

We will inform the Stock Exchange as soon as we have been informed of the above matters (if any) by Fangyi Holdings, Junyi Holdings, Hou Weigui, Hu Xiang, any of the Beneficial Owners, Wang Guoying or Shao Zhiguo and disclose such matters by way of a press announcement which is to be posted on the website of the Stock Exchange and of our Company as soon as possible after being so informed by Fangyi Holdings, Junyi Holdings, Hou Weigui, Hu Xiang, any of the Beneficial Owners, Wang Guoying or Shao Zhiguo.

### UNDERTAKINGS PURSUANT TO THE HONG KONG UNDERWRITING AGREEMENT

#### By Us

Pursuant to the Hong Kong Underwriting Agreement, we have irrevocably and unconditionally undertaken to each of the Hong Kong Underwriters that the Group will not, and each of Fangyi Holdings, Junyi Holdings, Wang Guoying, Shao Zhiguo and Hu Xiang shall procure that the Group will not, save as pursuant to the Global Offering, the Capitalization Issue, the Over-allotment Option, the Pre-IPO Incentive Plans, the Share Option Scheme and the Stock Borrowing Agreement, without the prior written consent of the Global Coordinator (on behalf of all the Hong Kong Underwriters), directly or indirectly, take any of the following actions with respect to any of the Shares or any securities convertible into or exchangeable or exercisable for any of the Shares (collectively “Company’s Securities”):

- (a) at any time during the period commencing from the date of the Hong Kong Underwriting Agreement up to and including the date falling six months after the Listing Date, (i) allot, sell, issue, contract to sell, pledge or otherwise dispose of our Company’s Securities, (ii) allot, sell, issue, contract to sell, contract to purchase or grant any option, right or warrant to purchase our Company’s Securities, (iii) enter into any swap, hedge or any other agreement that transfers, in whole or in part, the economic consequences of ownership of our Company’s Securities or (iv) establish or increase a put equivalent position or liquidate or decrease a call equivalent position in our Company’s Securities (including, but not limited to, entering into an arrangement to purchase or sell any Shares where either (1) the person selling the Shares does not own the security sold or (2) if owning the security, the person selling the Shares delays delivery against such sale).
- (b) issue any Company Securities or grant or agree to grant any option, warrant or other right carrying the right to subscribe for or otherwise convert into or exchange for Company Securities or enter into any swap, derivative or other arrangement that transfers to another,

---

## UNDERWRITING

---

in whole or in part, any of the economic consequences of ownership of any such Company Securities, during the six-month period commencing on the expiry date of the First Six-Month Period (as defined in sub-paragraph (c) below) so as to result in that the Covenantors either individually or taken together with the others of them cease to own 30 per cent. or more of the issued share capital of the Company or the Company ceases to hold a controlling interest of 30 per cent. or more in any major subsidiary (which shall have the same meaning as in rule 13.25(2) of the Listing Rules) of the Group;

- (c) at any time for a six-month period commencing on the Listing Date (the “First Six-Month Period”), purchase any Company’s Securities.

Similar undertakings are expected to be given by us to the International Underwriters under the International Underwriting Agreement.

### **By Covenantors**

Pursuant to the Hong Kong Underwriting Agreement, each of Fangyi Holdings, Junyi Holdings, Wang Guoying, Shao Zhiguo and Hu Xiang agrees and undertakes to us, the Joint Sponsors and the Global Coordinator (for itself and on behalf of the Hong Kong Underwriters) that, save as pursuant to the Global Offering, the Over-allotment Option and the Stock Borrowing Agreement (if applicable) during the First Six-Month Period, Fangyi Holdings, Junyi Holdings, Wang Guoying, Shao Zhiguo and Hu Xiang will not, directly or indirectly, take any of the following actions with respect to any of the Shares in respect of which it, he or she is shown in this prospectus to be the beneficial owner (collectively, the “Lock-Up Shares”): (i) offer, sell, issue, contract to sell, pledge or otherwise dispose of the Lock-Up Shares, (ii) offer, sell, issue, contract to sell, contract to purchase or grant any option, right or warrant to purchase the Lock-Up Shares, (iii) enter into any swap, hedge or any other agreement that transfers, in whole or in part, the economic consequences of ownership of the Lock-Up Shares or (iv) establish or increase a put equivalent position or liquidate or decrease a call equivalent position in the Lock-Up Shares (including, but not limited to, entering into an arrangement to purchase or sell any Shares where either (1) the person selling the Shares does not own the security sold or (2) if owning the security, the person selling the Shares delays delivery against such sale). Additionally, during the period of six months commencing on the date on which the First Six-Month Period expires, Fangyi Holdings, Junyi Holdings, Wang Guoying, Shao Zhiguo and Hu Xiang will not enter into any of the foregoing transactions restricted during the First Six-Month Period or contract to or publicly announce any intention to enter into any such transactions if, immediately following such transactions, Fangyi Holdings, Junyi Holdings, Wang Guoying, Shao Zhiguo and Hu Xiang, considered together, will cease to own 30% or more of the issued share capital of the Company.

### **UNDERTAKING BY SB ASIA, CISCO AND MANITOU**

Pursuant to a deed of lock-up dated November 27, 2009 (“Deed of Lock-up”), each of SB Asia, Cisco and Manitou has severally agreed and undertaken, to us, the Global Coordinator and First Shanghai Securities that, save as pursuant to the Global Offering, the Over-allotment Option and the Stock Borrowing Agreement (if applicable), without the prior written consent of Piper Jaffray Asia Securities (on behalf of the Underwriters), during the period commencing on the date of the Deed of Lock-up and continue and include the six months after the Listing Date (provided that if during the last 14 days of such period, the Company releases earnings results or material news or a material event relating to the Company occurs, such period will be extended until the expiration of the one month period beginning on the date of release of the earnings results or the occurrence of the material news or material event, as applicable), SB Asia, Cisco and Manitou will not, directly or indirectly, take any of the following actions with respect to any of their respective Shares or securities convertible into or exchangeable or exercisable for any Shares (collectively, the “Other Lock-Up Shares”):

- (i) offer, sell, issue, contract to sell, pledge or otherwise dispose of the Other Lock-Up Shares,  
(ii) offer, sell, issue, contract to sell, contract to purchase or grant any option, right or warrant to

---

## UNDERWRITING

---

purchase any Other Lock-Up Shares, (iii) enter into any swap, hedge or any other agreement that transfers, in whole or in part, the economic consequences of ownership of the Other Lock-Up Shares or (iv) establish or increase a put equivalent position or liquidate or decrease a call equivalent position in the Other Lock-Up Shares (including, but not limited to, entering into an arrangement to purchase or sell any Shares where either (1) the person selling the Shares does not own the security sold or (2) if owning the security, the person selling the Shares delays delivery against such sale), whether any such aforementioned transaction is to be settled by delivery of the Shares or such other securities, in cash or otherwise, or contract to or publicly disclose the intention to make any such offer, sale, pledge or disposition, or to enter into any such transaction, swap, hedge or other arrangement.

Notwithstanding the foregoing, SB Asia, Cisco and Manitou may transfer the Other Lock-up Shares to any wholly-owned subsidiaries of their respective parent entities, provided that such transfer is made with no or nominal consideration and such subsidiary agrees to abide by the terms and restrictions in the Deed of Lock-up.

### **Total Commission and Expenses**

In connection with the Global Offering, the Underwriters will receive an underwriting commission of 2.75%, and may receive an additional incentive fee of 1.25%, of the aggregate Offer Price of all the Offer Shares initially offered under the Global Offering and the Shares to be issued pursuant to exercise of the Over-allotment Option (if applicable), out of which they will pay any sub-underwriting commission. For unsubscribed Hong Kong Offer Shares reallocated to the International Placing, we will pay an underwriting commission at the rate applicable to the International Placing and such commission will be paid to the Global Coordinator and the relevant International Underwriters (but not the Hong Kong Underwriters).

The aggregate commissions and fees, together with Stock Exchange listing fees, filing fees, SFC transaction levy, Stock Exchange trading fee, CCASS transaction fees, legal and other professional fees and printing and other expenses relating to the Global Offering are estimated to range from approximately HK\$33.6 million to approximately HK\$37.4 million (assuming the Over-allotment Option is not exercised) and are payable by our Company.

Each of our Company, Fangyi Holdings, Junyi Holdings, Wang Guoying, Shao Zhigua and Hu Xiang has agreed jointly and severally to indemnify the Hong Kong Underwriters for certain losses which they may suffer, including losses incurred arising from their performance of their obligations under the Hong Kong Underwriting Agreement and any breach by our Company of the Hong Kong Underwriting Agreement. Similar indemnities are expected to be given by us to the International Underwriters under the International Underwriting Agreement.

### **Underwriters' Interests in Our Company**

Except for their respective obligations under the Hong Kong Underwriting Agreement and the International Underwriting Agreement, none of the Underwriters has any shareholding interests in our Group or the right or option (whether legally enforceable or not) to subscribe for or nominate persons to subscribe for securities in any member of our Group. Following the completion of the Global Offering, the Underwriters and their affiliated companies may hold an additional portion of our Shares as a result of exercising their rights or fulfilling their obligations under the Underwriting Agreements.

### **Joint Sponsor's Independence**

The Joint Sponsors satisfy the independence criteria applicable to sponsors as required under Rule 3A.07 of the Listing Rules.

---

## STRUCTURE OF THE GLOBAL OFFERING

---

### Offer Price and Price Payable on Application

The Offer Price payable by the applicants for the Offer Shares will be HK\$3.50 per Offer Share, plus 1% brokerage fee, 0.004% SFC transaction levy and 0.005% Stock Exchange trading fee. This means that for every board lot of 1,000 Shares, you should pay HK\$3,535.32 at the time of your application.

If the Offer Price, as finally determined in the manner described below, is lower than HK\$3.50, we will refund the respective difference, including the brokerage fee, Stock Exchange trading fee and SFC transaction levy attributable to the surplus application monies. We will not pay interest on any refunded amounts. Further details are set out in the section headed “How to apply for Hong Kong Offer Shares” in this prospectus.

### Determining the Offer Price

The Offer Price is expected to be fixed by Price Determination Agreement on the Price Determination Date, when market demand for the Offer Shares will be determined. The Price Determination Date is expected to be on or around December 10, 2009, and in any event, not later than December 12, 2009.

The Offer Price will not be more than HK\$3.50 per Offer Share. The Offer Price will fall within the offer price range as stated in this prospectus unless otherwise announced, as further explained below, not later than the morning of the last day for lodging applications under the Hong Kong Public Offering.

The Global Coordinator, on behalf of the Underwriters, may, where considered appropriate based on the level of interest expressed by prospective professional, institutional and other investors during a book-building process, and with the consent of our Company, reduce the number of Offer Shares and/or the indicative offer price range below that is stated in this prospectus prior to the morning of the last day for lodging applications under the Hong Kong Public Offering. In such a case, we will as soon as practicable following the decision to make such reduction and in any event not later than the morning of the last day for lodging applications under the Hong Kong Public Offering publish a notice in the South China Morning Post (in English) and the Hong Kong Economic Times (in Chinese) and on the website of the Company ([www.mobi-antenna.com](http://www.mobi-antenna.com)) and the website of the Stock Exchange ([www.hkex.com.hk](http://www.hkex.com.hk)) of the reduction in the number of Offer Shares and/or the indicative offer price range.

Upon issue of such a notice, the revised number of Offer Shares and/or offer price range will be final and conclusive and the Offer Price, if agreed upon by us, will be fixed within such revised offer price range. In this notice, we will also confirm or revise, as appropriate, the working capital statement, the Global Offering statistics as currently set out in the section headed “Summary” in this prospectus, and any other financial information which may change as a result of such reduction. If we do not publish a notice in the South China Morning Post (in English) and the Hong Kong Economic Times (in Chinese) and on the website of the Company ([www.mobi-antenna.com](http://www.mobi-antenna.com)) and the website of the Stock Exchange ([www.hkex.com.hk](http://www.hkex.com.hk)) of a reduction in the number of Offer Shares and/or the indicative offer price range stated in this prospectus on or before the morning of the last day for lodging applications under the Hong Kong Public Offering, the Offer Price, if agreed upon by the Global Coordinator, on behalf of the Underwriters, and us, will be within the offer price range as stated in this prospectus. Before submitting applications for Hong Kong Offer Shares, applicants should have regard to the possibility that any announcement of a reduction in the number of Offer Shares and/or the indicative offer price range may not be made until the day which is the last day for lodging applications under the Hong Kong Public Offering.

---

## STRUCTURE OF THE GLOBAL OFFERING

---

If we are unable to reach agreement with the Global Coordinator (on behalf of the Underwriters) on the Offer Price by December 12, 2009, the Global Offering (including the Hong Kong Public Offering) will not proceed and will lapse.

The applicable Offer Price, level of applications in the Hong Kong Public Offering, the level of indications of interest in the International Placing, and the basis of allocations of the Hong Kong Offer Shares are expected to be announced on December 16, 2009 through a variety of channels as described in the section headed “How to apply for Hong Kong Offer Shares” in this prospectus.

### Conditions of the Global Offering

Acceptance of all applications for the Global Offering will be conditional upon, among other things:

- (i) the Listing Committee of the Stock Exchange granting listing of, and permission to deal in, the Shares in issue and to be issued as mentioned in this prospectus, including the Offer Shares, the Shares to be issued upon conversion of the Series A Preferred Shares, any Shares which may be issued pursuant to the Capitalization Issue, the exercise of the Over-allotment Option, the exercise of the Pre-IPO Options and the exercise of any options that may be granted under the Share Option Scheme, and such listing and permission not subsequently being revoked prior to the Listing;
- (ii) the Offer Price having been duly determined on the Price Determination Date; and
- (iii) the obligations of the Underwriters under the Underwriting Agreements becoming unconditional (including the waiver of any condition(s) by the Global Coordinator on behalf of the Underwriters) and not being terminated in accordance with the terms of those agreements,

in each case on or before the dates and times specified in the Underwriting Agreements (unless and to the extent such conditions are validly waived on or before such dates and times) and in any event not later than the date which is 30 days after the date of this prospectus.

The consummation of each of the Hong Kong Public Offering and the International Placing is conditional upon, among other things, the other offering becoming unconditional and not having been terminated in accordance with its terms.

If the above conditions are not fulfilled or waived prior to the times and dates specified, the Global Offering will lapse and the Stock Exchange will be notified immediately. We will publish a notice of the lapse of the Global Offering in the South China Morning Post (in English) and the Hong Kong Economic Times (in Chinese) and on the website of the Company ([www.mobi-antenna.com](http://www.mobi-antenna.com)) and the website of the Stock Exchange ([www.hkex.com.hk](http://www.hkex.com.hk)) on the Business Day immediately after such lapse.

In the above situation, we will return all application monies to the applicants, without interest and on the terms set out in the section headed “How to apply for Hong Kong Offer Shares” in this prospectus. In the meantime, we will hold all application monies in a separate bank account or separate bank accounts with the receiving banker or other licensed bank(s) in Hong Kong.

We expect to issue share certificates for the Offer Shares on December 16, 2009. However, these share certificates will only become valid certificates of title at 8:00 a.m. on December 17, 2009, provided that (i) the Global Offering has become unconditional in all respects, and (ii) the right of termination as described in the section headed “Underwriting” in this prospectus has not been exercised.

---

## STRUCTURE OF THE GLOBAL OFFERING

---

### The Global Offering

Our Global Offering consists of the Hong Kong Public Offering and the International Placing of an aggregate of 175,515,000 Offer Shares (assuming the Over-allotment Option is not exercised).

You may apply for the Hong Kong Offer Shares under the Hong Kong Public Offering or indicate an interest for the International Placing Shares under the International Placing, but you may not apply under both of these methods for the Offer Shares. In other words, you may only receive Offer Shares under either the International Placing or the Hong Kong Public Offering, but not under both of these methods. The Hong Kong Public Offering is open to members of the public in Hong Kong as well as to institutional and professional investors. The International Placing will involve selective marketing of the International Placing Shares to institutional and professional investors and other investors anticipated to have a sizeable demand for Shares. Professional investors generally include brokers, dealers, companies (including fund managers) whose ordinary business involves dealing in shares and other securities and corporate entities which regularly invest in shares and other securities. Prospective professional, institutional and other investors will be required to specify the number of the International Placing Shares under the International Placing they would be prepared to acquire either at different prices or at a particular price. This process, known as “book-building,” is expected to continue up to the Price Determination Date.

Allocation of the International Placing Shares pursuant to the International Placing will be determined by the Global Coordinator and will be based on a number of factors including the level and timing of demand, total size of the relevant investor’s invested assets or equity assets in the relevant sector and whether or not it is expected that the relevant investor is likely to buy further, and/or hold or sell its Shares, after the Listing. Such allocation is intended to result in a distribution of the International Placing Shares on a basis which would lead to the establishment of a solid shareholder base to the benefit of us and our shareholders as a whole.

Allocation of Hong Kong Offer Shares to investors under the Hong Kong Public Offering will be based on the level of valid applications received under the Hong Kong Public Offering. The basis of allocation may vary depending on the number of Hong Kong Offer Shares validly applied for by applicants. We may, if necessary, allocate the Hong Kong Offer Shares on the basis of balloting, which would mean that some applicants may receive a higher allocation than others who have applied for the same number of Hong Kong Offer Shares and those applicants who are not successful in the ballot may not receive any Hong Kong Offer Shares.

In connection with the Global Offering, our Company intends to grant the Over-allotment Option to the Global Coordinator (on behalf of the International Underwriters). The Over-allotment Option gives the Global Coordinator the right exercisable at any time from the date of the International Underwriting Agreement up to (and including) the date which is the 30th day from the last day for the lodging of applications under the Hong Kong Public Offering to require our Company to issue up to an aggregate of 26,327,000 additional New Shares, representing approximately 15% of the initial size of the Global Offering at the Offer Price to cover, among other things, over-allocations in the International Placing, if any. The Global Coordinator may also cover such over-allocations by purchasing the Offer Shares in the secondary market or by a combination of purchases in the secondary market and a partial exercise of the Over-allotment Option. Any such secondary market purchase will be made in compliance with all applicable laws, rules and regulations. In the event that the Over-allotment Option is exercised, an announcement will be made.

The 175,515,000 Offer Shares initially being offered in the Global Offering by us will represent approximately 25% of our enlarged share capital immediately after completion of the Global Offering, without taking into account the exercise of the Over-allotment Option.

The Hong Kong Public Offering is fully underwritten by the Hong Kong Underwriters and the International Placing is expected to be fully underwritten by the International Underwriters. The Hong Kong Public Offering and the International Placing are subject to the conditions set out in the section

---

## STRUCTURE OF THE GLOBAL OFFERING

---

headed “Underwriting — Underwriting arrangements and expenses” in this prospectus. In particular, we must agree the Offer Price with the Global Coordinator (on behalf of the Underwriters). The Hong Kong Underwriting Agreement was entered into on December 3, 2009 and subject to the Price Determination Agreement, the International Underwriting Agreement is expected to be entered into on December 10, 2009. The Hong Kong Underwriting Agreement and the International Underwriting Agreement are interconditional upon each other.

### **The Hong Kong Public Offering**

The Hong Kong Public Offering is a fully underwritten public offer (subject to agreement as to pricing and satisfaction or waiver of the other conditions set out in the Hong Kong Underwriting Agreement and described in the paragraph headed “Conditions of the Global Offering” in this section) for the subscription in Hong Kong of, initially, 17,552,000 Offer Shares at the Offer Price (representing approximately 10% of the total number of the Offer Shares initially available under the Global Offering). Subject to the reallocation of Offer Shares between the International Placing and the Hong Kong Public Offering, the Hong Kong Offer Shares will represent approximately 2.5% of our enlarged issued share capital immediately after completion of the Global Offering assuming that the Over-allotment Option is not exercised.

The total number of the Offer Shares available under the Hong Kong Public Offering is to be divided equally into two pools for allocation purposes:

- Pool A: The Offer Shares in pool A will be allocated on an equitable basis to applicants who have applied for the Hong Kong Offer Shares with an aggregate subscription price of HK\$5 million (excluding the brokerage, the Stock Exchange trading fee and the SFC transaction levy payable) or less; and
- Pool B: The Offer Shares in pool B will be allocated on an equitable basis to applicants who have applied for the Hong Kong Offer Shares with an aggregate subscription price of more than HK\$5 million (excluding the brokerage, the Stock Exchange trading fee and the SFC transaction levy payable) and up to the value of pool B.

Investors should be aware that applications in pool A and applications in pool B may receive different allocation ratios. If the Offer Shares in one (but not both) of the pools are under-subscribed, the surplus Offer Shares will be transferred to the other pool to satisfy demand in the pool and be allocated accordingly. For the purpose of this subsection only, the “subscription price” for the Offer Shares means the price payable on application therefor (without regard to the Offer Price as finally determined).

### *Rejection of Applications*

Applicants can only receive an allocation of the Hong Kong Offer Shares from either pool A or pool B but not from both pools. Multiple or suspected multiple applications within pool A or pool B, and between the two pools will be rejected. Any application for more than 50% of the 17,552,000 Offer Shares initially included in the Hong Kong Public Offering (that is, 8,776,000 Offer Shares) will be rejected. Each applicant under the Hong Kong Public Offering will be required to give an undertaking and confirmation that he or she and any person(s) for whose benefit he or she is making the application have not indicated an interest for or taken up and will not indicate an interest for or take up any Offer Shares under the International Placing, and such applicant’s application will be rejected if the said undertaking and/or confirmation is breached and/or untrue (as the case may be). Our Directors, the Hong Kong Underwriters, the Joint Sponsors and us will take reasonable steps to identify and reject applicants in the Hong Kong Public Offering from investors who have received Shares in the International Placing, and to identify and reject indications of interest in the International Placing from investors who have received Shares in the Hong Kong Public Offering.

---

## STRUCTURE OF THE GLOBAL OFFERING

---

### *Clawback Mechanism*

The allocation of the Offer Shares between the Hong Kong Public Offering and the International Placing is subject to the following adjustments in the event of over-subscription under the Hong Kong Public Offering:

- if the number of the Offer Shares validly applied for under the Hong Kong Public Offering represents 15 times or more but less than 50 times the number of the Offer Shares initially available for subscription under the Hong Kong Public Offering, then International Placing Shares will be reallocated to the Hong Kong Public Offering from the International Placing, so that the total number of the Offer Shares available under the Hong Kong Public Offering will be 52,656,000 Offer Shares, representing approximately 30% of the Offer Shares initially available under the Global Offering;
- if the number of the Offer Shares validly applied for under the Hong Kong Public Offering represents 50 times or more but less than 100 times the number of the Offer Shares initially available for subscription under the Hong Kong Public Offering, then the number of International Placing Shares to be reallocated to the Hong Kong Public Offering from the International Placing will be increased, so that the total number of the Offer Shares available under the Hong Kong Public Offering will be 70,206,000 Offer Shares, representing 40% of the Offer Shares initially available under the Global Offering; and
- if the number of the Offer Shares validly applied for under the Hong Kong Public Offering represents 100 times or more the number of the Offer Shares initially available for subscription under the Hong Kong Public Offering, then the number of International Placing Shares to be reallocated to the Hong Kong Public Offering from the International Placing will be increased, so that the total number of the Offer Shares available under the Hong Kong Public Offering will be 87,758,000 Offer Shares, representing approximately 50% of the Offer Shares initially available under the Global Offering.

If the Hong Kong Public Offering is not fully subscribed, the Global Coordinator may, at its discretion, reallocate to the International Placing all or any unsubscribed Hong Kong Offer Shares in such numbers as it deems appropriate.

References in this prospectus to applications, application or subscription monies or the procedure for application relate solely to the Hong Kong Public Offering.

### **The International Placing**

We will be initially offering for subscription under the International Placing 157,963,000 Offer Shares, representing approximately 90% of the Offer Shares under the Global Offering and approximately 22.5% of our enlarged issued share capital immediately after completion of the Global Offering assuming the Over-allotment Option is not exercised.

Pursuant to the International Placing, the International Placing Shares will be conditionally placed on behalf of us by the International Underwriters or through selling agents appointed by them. International Placing Shares will be placed with certain professional and institutional investors and other investors anticipated to have a sizeable demand for such International Placing Shares in Hong Kong and other jurisdictions outside the United States in offshore transactions in reliance on Regulation S. The International Placing is subject to the Hong Kong Public Offering becoming unconditional.

The Global Coordinator (on behalf of the Underwriters) may require any investor who has been offered Offer Shares under the International Placing and who has made an application under the Hong Kong Public Offering to provide sufficient information to the Global Coordinator so as to allow them to identify the relevant applications under the Hong Kong Public Offering and to ensure that it is excluded from any applications of Hong Kong Offer Shares under the Hong Kong Public Offering.

---

## STRUCTURE OF THE GLOBAL OFFERING

---

### Over-Allotment and Stabilization

Stabilization is a practice used by underwriters in some markets to facilitate the distribution of securities. To stabilize, the underwriters may bid for, or purchase, the newly issued securities in the secondary market, during a specified period of time, to retard and, if possible, prevent a decline in the initial public offer prices of the securities. In Hong Kong and certain other jurisdictions, activity aimed at reducing the market price is prohibited, and the price at which stabilization is effected is not permitted to exceed the offer price.

In connection with the Global Offering, the Global Coordinator, as stabilizing manager, or, any person acting for it, may over-allocate or effect any other transactions with a view to stabilizing or maintaining the market price of the Shares at a level higher than that which might otherwise prevail in the open market for a limited period from Listing Date and ending on the 30th day after the last day for the lodging of applications under the Hong Kong Public Offering. Stabilizing action permitted in Hong Kong pursuant to the Securities and Futures (Price Stabilization) Rules includes (i) over-allocation for the purpose of preventing or minimizing any reduction in the market price, (ii) selling or agreeing to sell Shares so as to establish a short position in them for the purpose of preventing or minimizing any reduction in the market price, (iii) subscribing, purchasing, or agreeing to subscribe or purchase, shares pursuant to the Over-allotment Option in order to close out any position established under (i) or (ii) above, (iv) purchasing, or agreeing to purchase, Shares for the sole purpose of preventing or minimizing any reduction in the market price, (v) selling, or agreeing to sell, Shares to liquidate any long position held as a result of those purchases in (iv) and (vi) offering or attempting to do anything described in (ii), (iii), (iv) or (v). Any market purchases will be effected in compliance with all applicable laws and regulatory requirements. However there is no obligation on the Global Coordinator or any person acting for it to conduct any such stabilizing activity, which if commenced, will be done at the absolute discretion of the Global Coordinator or any person acting for it and may be discontinued at any time. Any such stabilizing activity is required to be brought to an end within 30 days of the last day for the lodging of applications under the Hong Kong Public Offering. The number of Shares that may be over-allocated will not exceed the number of Shares that may be issued upon exercise of the Over-allotment Option, being 26,327,000 Shares, which is approximately 15% of the number of Shares initially available under the Global Offering.

As a result of effecting transactions to stabilize or maintain the market price of the Shares, the Global Coordinator, or any person acting for it, may maintain a long position in the Shares. The size of the long position, and the period for which the Global Coordinator, or any person acting for it, will maintain the long position is at the discretion of the Global Coordinator and is uncertain. In the event that the Global Coordinator liquidates this long position by making sales in the open market, this may lead to a decline in the market price of the Shares.

Stabilizing action by the Global Coordinator, or any person acting for it, is not permitted to support the price of the Shares for longer than the stabilizing period, which begins on the day on which trading of the Shares commences on the Stock Exchange and ends on the thirtieth day after the last day for the lodging of applications under the Hong Kong Public Offering. The stabilizing period is expected to end on January 8, 2010. As a result, demand for the Shares, and its market price, may fall after the end of the stabilizing period. A public announcement will be made within seven days after the end of the stabilizing period in accordance with the Securities and Futures (Price Stabilizing) Rules.

Any stabilizing action taken by the Global Coordinator, or any person acting for it, may not necessarily result in the market price of the Shares staying at or above the Offer Price either during or after the stabilizing period. Bids for on-market purchases of the Shares by the Global Coordinator, or any person acting for it, may be made at a price at or below the Offer Price and therefore at or below the price paid for the Shares by subscribers or purchasers.

---

## STRUCTURE OF THE GLOBAL OFFERING

---

In order to facilitate the settlement of over-allocations in connection with the International Placing, the Stabilization Manager or its affiliates acting for it may choose to borrow Shares from our shareholder, Fangyi Holdings under the Stock Borrowing Agreement. The Stock Borrowing Agreement shall not be subject to the restrictions of Rule 10.07(1)(a) of the Listing Rules provided that the requirements set forth in Rule 10.07(3) of the Listing Rules are to be complied with as follows:

- such stock borrowing arrangement with Fangyi Holdings will only be effected by the Stabilization Manager for settlement of over-allocations in the International Placing and covering any short position prior to the exercise of the Over-allotment Option;
- the maximum number of Shares borrowed from Fangyi Holdings under the Stock Borrowing Agreement will be limited to the maximum number of Shares which may be issued upon exercise of the Over-allotment Option;
- the same number of Shares so borrowed must be returned to Fangyi Holdings or its nominees on or before the third Business Day following the earlier of (i) the last day on which the Over-allotment Option may be exercised, or (ii) the day on which the Over-allotment Option is exercised in full;
- the stock borrowing arrangement under the Stock Borrowing Agreement will be effected in compliance with all applicable laws, listing rules and regulatory requirements; and
- no payment will be made to Fangyi Holdings by the Stabilization Manager or its authorized agents in relation to such stock borrowing arrangement.

---

## HOW TO APPLY FOR HONG KONG OFFER SHARES

---

### I. METHODS OF APPLYING FOR THE HONG KONG OFFER SHARES

There are three ways to make an application for Hong Kong Offer Shares. You may either (i) use a **White** or **Yellow** Application Form; (ii) apply online through the designated website of the White Form eIPO Service Provider, referred to here in as the “**White Form eIPO**” service ([www.eipo.com.hk](http://www.eipo.com.hk)); or (iii) give **electronic application instruction** to HKSCC to cause HKSCC Nominees to apply for Hong Kong Offer Shares on your behalf. Except where you are a nominee and provide the required information in your application, you or you and your joint applicant(s) may not make more than one application (whether individually or jointly) by applying on a **White** or **Yellow** Application Form or applying online through **White Form eIPO** service or by giving **electronic application instructions** to HKSCC.

### II. WHO CAN APPLY FOR HONG KONG OFFER SHARES

You may apply for Hong Kong Offer Shares available for subscription by the public on a **White** or **Yellow** Application Form if you, or any person(s) for whose benefit you are applying, are an individual and:

- are 18 years of age or older;
- have a Hong Kong address;
- are outsider United States (as defined in Regulation S); and
- are not a legal or natural person of the PRC (except qualified domestic institutional investors).

If the applicant is a firm, the application must be in the names of the individual members, not the firm’s name. If the applicant is a body corporate, the Application Form must be signed by a duly authorized officer, who must state his or her representative capacity.

If an application is made by a person duly authorized under a valid power of attorney, the Global Coordinator (or its respective agents or nominees) may accept it at its discretion, and subject to any conditions it thinks fit, including production of evidence of the authority of the attorney.

The number of joint applicants may not exceed four.

### III. WHO CAN APPLY FOR HONG KONG OFFER SHARES BY MEANS OF WHITE FORM eIPO

If you wish to apply for Hong Kong Offer Shares online through the **White Form eIPO** service ([www.eipo.com.hk](http://www.eipo.com.hk)), you must also:

- have a valid Hong Kong identity card number; and
- be willing to provide a valid e-mail address and a contact telephone number.

You may only apply by means of the **White Form eIPO** service if you are an individual applicant. Corporations or joint applicants may not apply by means of **White Form eIPO**.

---

## HOW TO APPLY FOR HONG KONG OFFER SHARES

---

### IV. APPLYING BY USING A WHITE OR YELLOW APPLICATION FORM

#### 1. Which Application method to use

- (a) Use a **White** Application Form if you want the Hong Kong Offer Shares to be issued in your own name.
- (b) Instead of using a **White** Application Form, you may apply for the Hong Kong Offer Shares by means of **White Form eIPO** by submitting applications online through the designated website at [www.eipo.com.hk](http://www.eipo.com.hk). Use **White Form eIPO** if you want the Shares issued in your own name.
- (c) Use a **Yellow** Application Form if you want the Hong Kong Offer Shares to be issued in the name of HKSCC Nominees and deposited directly into CCASS for credit to your CCASS Investor Participant stock account or your designated CCASS Participant's stock account.
- (d) Instead of using a **Yellow** Application Form, you may give **electronic application instructions** to HKSCC to cause HKSCC Nominees to apply for the Hong Kong Offer Shares on your behalf.

*Note:* The Hong Kong Offer Shares are not available to existing beneficial owners of Shares, Directors or chief executives of our Company or any of its subsidiaries, or associates of any of them (an "associate" as defined in the Listing Rules) or to a connected person of our Company or a person who is a United States person (as defined in Regulation S) under the U.S. Securities Act or persons who do not have a Hong Kong address.

#### 2. Where to collect the Application Forms

- (a) You can collect a White Application Form and this prospectus during normal business hours from 9:00 a.m. on December 4, 2009 until 12:00 noon on December 9, 2009 from:

any of the following addresses of the Joint Sponsors and the Hong Kong Underwriters:

#### Joint Sponsors

Piper Jaffray Asia Limited  
3902B, 39/F, Tower 1  
Lippo Centre  
89 Queensway  
Hong Kong

First Shanghai Capital Limited  
19/F, Wing On House  
71 Des Voeux Road Central  
Hong Kong

#### Hong Kong Underwriters

Piper Jaffray Asia Securities Limited  
3901B, 39/F, Tower 1  
Lippo Centre  
89 Queensway  
Hong Kong

First Shanghai Securities Limited  
19/F Wing On House,  
71 Des Voeux Road Central  
Hong Kong

---

## HOW TO APPLY FOR HONG KONG OFFER SHARES

---

Taifook Securities Company Limited  
 25/F, New World Tower  
 16-18 Queen's Road, Central  
 Hong Kong

or any of the following branches of Standard Chartered Bank (Hong Kong) Limited:

District	Branch	Address
Hong Kong Island	Central Branch	Shop no. 16, G/F and Lower G/F New World Tower 16-18 Queen's Road Central Central
	88 Des Voeux Road Branch	88 Des Voeux Road Central Central
	Leighton Centre Branch	Shop 12-16, UG/F Leighton Centre 77 Leighton Road Causeway Bay
	Hennessy Road Branch	399 Hennessy Road Wanchai
	Causeway Bay Branch	G/F, Yee Wah Mansion 38-40A Yee Wo Street Causeway Bay
	Quarry Bay Branch	G/F, Westlands Gardens 1027 King's Road Quarry Bay
	North Point Centre Branch	North Point Centre 284 King's Road North Point
	Aberdeen Branch	Shop 4A, G/F, Aberdeen Centre Site 5, No.6 Nam Ning Street Aberdeen
Kowloon	Kwun Tong Branch	1A Yue Man Square Kwun Tong
	Mongkok Branch	Shop B, G/F, 1/F & 2/F 617-623 Nathan Road Mongkok
	Tsimshatsui Branch	G/F, 10 Granville Road Tsimshatsui
	San Po Kong Branch	Shop A, G/F Perfect Industrial Building 31 Tai Yau Street San Po Kong
	Telford Gardens Branch	Shop P9-12, Telford Centre, Telford Gardens, Tai Yip Street Kwun Tong
	Lok Fu Shopping Centre Branch	Shop G101, G/F Lok Fu Shopping Centre

---

## HOW TO APPLY FOR HONG KONG OFFER SHARES

---

District	Branch	Address
New Territories	Shatin Centre Branch	Shop 32C, Level 3 Shatin Shopping Arcade Shatin Centre 2-16 Wang Pok Street Shatin
	Tsuen Wan Branch	Shop C, G/F & 1/F Jade Plaza 298 Sha Tsui Road Tsuen Wan
	Metroplaza Branch	Shop No. 175 - 176 Level 1, Metroplaza 223 Hing Fong Road Kwai Chung
	Yuen Long Branch	140 Yuen Long Main Road Yuen Long
	Tuen Mun Town Plaza Branch	Shop No. G047 - G052 Tuen Mun Town Plaza, Phase I Tuen Mun
	Tseung Kwan O Branch	Shop G37-40, G/F, Hau Tak Shopping Centre East Wing Hau Tak Estate Tseung Kwan O

- (b) You can collect a **Yellow** Application Form and this prospectus during normal business hours from 9:00 a.m. on December 4, 2009 until 12:00 noon on December 9, 2009 from:
- (1) the **Depository Counter of HKSCC** at 2nd Floor, Vicwood Plaza, 199 Des Voeux Road Central, Hong Kong; or
  - (2) your stockbroker, who may have such Application Forms and this prospectus available.

### 3. How to complete the Application Form

There are detailed instructions on each Application Form. You should read these instructions carefully. If you do not follow the instructions, your application may be rejected and returned by ordinary post together with the accompanying check or banker's cashier order to you (or the first-named applicant in the case of joint applicants) at your own risk at the address stated in the Application Form.

You should note that by completing and submitting the Application Form, amongst other things, you:

- (i) agree with our Company and each of its shareholders, and our Company agrees with each of its shareholders, to observe and comply with the companies law to which our Company is subject and the Memorandum and the Articles;
- (ii) agree with our Company and each of its shareholder that the Shares are freely transferable by the holders thereof;
- (iii) authorize our Company to enter into a contract on your behalf with each of our Directors and officers of our Company whereby each such Director and officer undertakes to observe and comply with their obligations to shareholders as stipulated in the Memorandum and the Articles;

---

## HOW TO APPLY FOR HONG KONG OFFER SHARES

---

- (iv) confirm that you have received a copy of this prospectus and have only relied on the information and representations contained in this prospectus (save as set out in any supplement to this prospectus) in making your application, and not on any other information or representation concerning our Company and you agree that neither our Company, the Joint Sponsors, the Global Coordinator and the Underwriters nor any of their respective directors, officers, employees, partners, agents, advisors or any other parties involved in the Global Offering will have any liability for any such other information or representations;
- (v) undertake and confirm that, you (if the application is made for your benefit) or the person(s) for whose benefit you have made the application have not applied for or taken up, or indicated an interest in or received or been placed or allocated (including conditionally and/or provisionally) and will not apply for or take up or indicate any interest in any International Placing Shares in the International Placing, nor otherwise participate in the International Placing;
- (vi) agree to disclose to our Company, its Hong Kong Share Registrar, receiving banker, the Joint Sponsors, the Global Coordinator and their respective advisors and agents personal data and any information which they require about you or the person(s) for whose benefit you have made the application;
- (vii) instruct and authorize our Company and/or the Global Coordinator and/or the Hong Kong Underwriters (or their respective agents or nominees) to execute any transfer forms, contract notes or other documents on your behalf and to do on your behalf all things necessary to effect registration of any Hong Kong Offer Shares allocated to you in your name(s) or in the name of HKSCC Nominees, as the case may be, as required by the Articles and otherwise to give effect to the arrangements described in this prospectus and the Application Forms;
- (viii) agree (without prejudice to any other rights which you may have) that once your application has been accepted, you may not revoke or rescind it because of an innocent misrepresentation;
- (ix) agree to accept the Shares allocated to you under the application; and warrant the truth and accuracy of the information contained in your application;
- (x) agree that your application, any acceptance of it and the resulting contract will be governed by and construed in accordance with the laws of Hong Kong;
- (xi) confirm that you have read the terms and conditions and application procedures set out in this prospectus and the Application Forms and agree to be bound by them;
- (xii) undertake and agree to accept the Hong Kong Offer Shares applied for, or any lesser number allocated to you under the application; and
- (xiii) if the laws of any place outside Hong Kong are applicable to your application, you agree and warrant that you have complied with all such laws and none of our Company, the Global Coordinator, the Joint Sponsors and the Underwriters nor any of their respective directors, officers, employees, partners, agents, advisors or any other parties involved in the Global Offering will infringe any laws outside Hong Kong as a result of the acceptance of your offer to subscribe, or any actions arising from your rights and obligations under the terms and conditions set out in this prospectus.

---

## HOW TO APPLY FOR HONG KONG OFFER SHARES

---

In order for the **Yellow** Application Form to be valid:

You, as the applicants, must complete the form as indicated below and sign on the first page of the Application Form. Only written signatures will be accepted.

- (i) **If the application is made through a designated CCASS Participant (other than a CCASS Investor Participant):**
  - (a) the designated CCASS Participant must endorse the form with its company chop (bearing its company name) and insert its participant I.D. in the appropriate box.
- (ii) **If the application is made by an individual CCASS Investor Participant:**
  - (a) the Application Form must contain the CCASS Investor Participant's name and Hong Kong Identity Card number; and
  - (b) the CCASS Investor Participant must insert its participant I.D. in the appropriate box in the Application Form.
- (iii) **If the application is made by a joint individual CCASS Investor Participant:**
  - (a) the Application Form must contain all joint CCASS Investor Participants' names and the Hong Kong Identity Card number of all joint CCASS Investor Participants; and
  - (b) the participant I.D. must be inserted in the appropriate box in the Application Form.
- (iv) **If the application is made by a corporate CCASS Investor Participant:**
  - (a) the Application Form must contain the CCASS Investor Participant's company name and Hong Kong Business Registration number; and
  - (b) the participant I.D. and company chop (bearing its company name) must be inserted in the appropriate box in the Application Form.

Incorrect or omission of details of the CCASS Participant (including participant I.D. and/or company chop bearing its company name) or other similar matters may render your application invalid.

If your application is made through a duly authorized attorney, our Company and the Global Coordinator (as its agents and on behalf of the Hong Kong Underwriters) may accept it at their discretion, and subject to any conditions they think fit, including evidence of the authority of your attorney. Our Company and the Global Coordinator, in the capacity (as its agents and on behalf of the Hong Kong Underwriters), will have full discretion to reject or accept any application, in full or in part, without assigning any reason.

#### **4. How to make payment for the Application Form**

Each completed **White** or **Yellow** Application Form must be accompanied by either one check or one banker's cashier order, which must be stapled to the top left hand corner of the Application Form.

If you pay by check, the check must:

- be in Hong Kong dollars;
- be drawn on your Hong Kong dollar bank account in Hong Kong;
- bear an account name. This name must either be pre-printed on the check or endorsed on the reverse of the check by an authorized signatory of the bank on which it is drawn. This account name must be the same as the name on your Application Form (or, in the case of joint applicants, the name of the first-named applicant). If the check is drawn on a joint account, one of the joint account names must be the same as the name of the first-named applicant);

---

## HOW TO APPLY FOR HONG KONG OFFER SHARES

---

- be made payable to Horsford Nominees Limited — MOBI Public Offer;
- be crossed “Account Payee Only”; and
- not be post-dated.

Your application may be rejected if your check does not meet all of these requirements or is dishonored on first presentation.

If you pay by banker’s cashier order, the banker’s cashier order must:

- be in Hong Kong dollars;
- be issued by a licensed bank in Hong Kong and have your name certified on the reverse of the banker’s cashier order by an authorized signatory of the bank on which it is drawn. The name on the reverse of the banker’s cashier order and the name on the Application Form must be the same. If the application is a joint application, the name on the back of the banker’s cashier order must be the same as the name of the first-named applicant;
- be made payable to Horsford Nominees Limited — MOBI Public Offer;
- be crossed “Account Payee Only”; and
- not be post-dated.

Your application may be rejected if your banker’s cashier order does not meet all of these requirements.

The right is reserved to present all or any remittance for payment. However, your check or banker’s cashier order will not be presented for payment before 12:00 noon on December 9, 2009. Our Company will not give you a receipt for your payment. Our Company will keep any interest accrued on your application monies (up until, in the case of monies to be refunded, the date of despatch of refund checks). The right is also reserved to retain any Share certificates and/or any surplus application monies or refunds pending clearance of your check or banker’s cashier order.

### **5. Members of the public — time for applying for Hong Kong Offer Shares**

Completed **White** or **Yellow** Application Forms, together with the payment attached, must be lodged by 12:00 noon on December 9, 2009, or, if the application lists are not open on that day, by the time and date stated in the sub-paragraph headed “Effect of bad weather on the opening of the application lists” below.

Your completed Application Forms, together with payment attached, should be deposited in the special collection boxes provided at any of the branches of Standard Chartered Bank (Hong Kong) Limited listed under the section headed “Where to collect the Application Forms” above at the following times:

**Friday, December 4, 2009 — 9:00 a.m. to 5:00 p.m.**  
**Saturday, December 5, 2009 — 9:00 a.m. to 1:00 p.m.**  
**Monday, December 7, 2009 — 9:00 a.m. to 5:00 p.m.**  
**Tuesday, December 8, 2009 — 9:00 a.m. to 5:00 p.m.**  
**Wednesday, December 9, 2009 — 9:00 a.m. to 12:00 noon**

The application lists will be open **from 11:45 a.m. to 12:00 noon on December 9, 2009.**

No proceedings will be taken on applications for the Hong Kong Offer Shares and no allotment of any such Hong Kong Offer Shares will be made until after the closing of the application lists.

---

## HOW TO APPLY FOR HONG KONG OFFER SHARES

---

### 6. Effect of bad weather on the opening of the application lists

The application lists will not open if there is:

- a tropical cyclone warning signal number 8 or above; or
- a “black” rainstorm warning signal

in force in Hong Kong at any time between 9:00 a.m. to 12:00 noon, on December 9, 2009. Instead they will open between 11:45 a.m. and 12:00 noon on the next Business Day which does not have either of those warnings in Hong Kong in force at any time between 9:00 a.m. and 12:00 noon on such day.

If the application lists do not open and close on December 9, 2009, or if there is a tropical cyclone warning signal number 8 or above or “black” rainstorm warning signal in force in Hong Kong on the other dates mentioned in the section headed “Expected Timetable”, such dates may be affected and an announcement will be made in such event.

### 7. Publication of results

A notification announcement under Rule 2.17A of the Listing Rules which also includes the Offer Price, an indication of the level of interest in the International Placing, the level of applications of the Hong Kong Public Offering and the basis of allocation of the Hong Kong Public Offer Shares will be published by us on December 16, 2009 in South China Morning Post (in English) and Hong Kong Economic Times (in Chinese) and on the website of the Company ([www.mobi-antenna.com](http://www.mobi-antenna.com)) and the website of the Stock Exchange ([www.hkex.com.hk](http://www.hkex.com.hk)).

The results of allocations and the Hong Kong Identity Card/passport/Hong Kong Business Registration numbers of successful applicants under the Hong Kong Public Offering will be available at the times and date and in the manner specified below:

- results of allocations for the Hong Kong Public Offering will be available from the results of allocations website at [www.iporesults.com.hk](http://www.iporesults.com.hk) on a 24-hour basis from 8:00 a.m. on December 16, 2009 to 12:00 midnight on December 22, 2009. The user will be required to key in the Hong Kong identity card/passport/Hong Kong business registration number provided in his/her/its application to search for his/her/its own allocation result;
- results of allocations will be available from our Hong Kong Public Offering allocation results telephone enquiry line. Applicants may find out whether or not their applications have been successful and the number of Hong Kong Public Offering Shares allocated to them, if any, by calling 2862 8669 between 9:00 a.m. and 10:00 p.m. from December 16, 2009 to December 19, 2009;
- special allocation results booklets setting out the results of allocations will be available for inspection during opening hours of individual branches and sub-branches from December 16, 2009 to December 18, 2009 at all the receiving bank branches and sub-branches at the addresses set out in the section headed “How to apply for the Hong Kong Offer Shares — Where to collect the Application Forms”.

### 8. Despatch/Collection of Share certificates/e-Refund payment instructions/ refund checks

If an application is rejected, not accepted or accepted in part only, or if the Offer Price as finally determined is less than HK\$3.50 per Share (excluding brokerage, SFC transaction levy and Stock Exchange trading fee thereon) initially paid on application, or if the conditions of the Hong Kong Public Offering are not fulfilled in accordance with the section headed “Structure of the Global Offering — Conditions of the Global Offering” or if any application is revoked or any allotment

---

## HOW TO APPLY FOR HONG KONG OFFER SHARES

---

pursuant thereto has become void, the application monies, or the appropriate portion thereof, together with the related brokerage, SFC transaction levy and Stock Exchange trading fee, will be refunded, without interest. It is intended that special efforts will be made to avoid any undue delay in refunding application monies where appropriate.

No temporary documents of title will be issued with respect to the Hong Kong Offer Shares. No receipt will be issued for sums paid on application but, subject to personal collection as mentioned below, in due course there will be sent to you (or, in the case of joint applicants, to the first-named applicant) by ordinary post, at your own risk, to the address specified on your Application Form:

- (a) for applications on **White** Application Forms: (i) Share certificate(s) for all the Hong Kong Offer Shares applied for, if the application is wholly successful; or (ii) Share certificate(s) for the number of Hong Kong Offer Shares successfully applied for, if the application is partially successful (for wholly successful and partially successful applicants on **Yellow** Application Forms: Share certificates for their Hong Kong Offer Shares successfully applied for will be deposited into CCASS as described below); and/or
- (b) for applications on **White** or **Yellow** Application Forms, refund check(s) crossed “Account Payee Only” in favour of the applicant (or, in the case of joint applicants, the first-named applicant) for (i) the surplus application monies for the Hong Kong Offer Shares unsuccessfully applied for, if the application is partially unsuccessful; or (ii) all the application monies, if the application is wholly unsuccessful; and/or (iii) the difference between the Offer Price and the maximum offer price per Share paid on application in the event that the Offer Price is less than the offer price per Share initially paid on application, in each case including the brokerage of 1%, SFC transaction levy of 0.004% and Stock Exchange trading fee of 0.005%, attributable to such refund/surplus monies but without interest.

Subject to personal collection as mentioned below, refund checks for surplus application monies (if any) with respect to wholly and partially unsuccessful applications and the difference between the Offer Price and the offer price per Share initially paid on application (if any) under **White** or **Yellow** Application Forms; and Share certificates for wholly and partially successful applicants under **White** Application Forms are expected to be posted on or around December 16, 2009. The right is reserved to retain any Share certificate(s) and any surplus application monies pending clearance of check(s).

Share certificates will only become valid certificates of title at 8:00 a.m. on the Listing Date provided that the Hong Kong Public Offering has become unconditional in all respects and the right of termination described in the section headed “Underwriting — Grounds for termination” has not been exercised.

- (a) If you apply using a **White** Application Form:

If you apply for 1,000,000 Hong Kong Offer Shares or more on a **White** Application Form and have indicated your intention in your Application Form to collect your refund check(s) (where applicable) and/or Share certificate(s) (where applicable) from Computershare Hong Kong Investor Services Limited and have provided all information required by your Application Form, you may collect your refund check(s) (where applicable) and Share certificate(s) (where applicable) from our Hong Kong Share Registrar, Computershare Hong Kong Investor Services Limited at Shops 1712-1716, 17th Floor, Hopewell Centre, 183 Queen’s Road East, Wanchai, Hong Kong from 9:00 a.m. to 1:00 p.m. on December 16, 2009 or such other place and date as notified by our Company in the South China Morning Post (in English) and the Hong Kong Economic Times (in Chinese) as the place and date of collection/despatch of e-Refund payment instructions/refund checks/Share certificates. If you are an individual who opts for personal collection, you must not authorise any other person to make collection on your behalf. If you are a corporate applicant which opts for personal collection, you must attend by your authorized representative bearing a letter of authorization from your corporation stamped with your corporation’s chop. Both individuals and authorized representatives (if

---

## HOW TO APPLY FOR HONG KONG OFFER SHARES

---

applicable) must produce, at the time of collection, evidence of identity acceptable to Computershare Hong Kong Investor Services Limited. If you do not collect your refund check(s) (where applicable) and/or Share certificate(s) (where applicable) personally within the time specified for collection, they will be sent to the address as specified in your Application Form promptly thereafter by ordinary post and at your own risk.

If you apply for less than 1,000,000 Hong Kong Offer Shares or if you apply for 1,000,000 Hong Kong Offer Shares or more but have not indicated on your Application Form that you will collect your refund check(s) (where applicable) and/or Share certificate(s) (where applicable) in person, your refund check(s) (where applicable) and/or Share certificate(s) (where applicable) will be sent to the address on your Application Form on December 16, 2009, by ordinary post and at your own risk.

(b) If you apply using a **Yellow** Application Form:

If you apply for 1,000,000 Hong Kong Offer Shares or more and you have elected on your **Yellow** Application Form to collect your refund check (where applicable) in person, please follow the same instructions as those for **White** Application Form applicants as described above.

If you apply for less than 1,000,000 Hong Kong Offer Shares or if you apply for 1,000,000 Hong Kong Offer Shares or more but have not indicated on your Application Form that you will collect your refund check(s) (where applicable) in person, your refund check(s) (where applicable) will be sent to the address on your Application Form on December 16, 2009, by ordinary post and at your own risk.

If you apply for Hong Kong Offer Shares using a **Yellow** Application Form and your application is wholly or partially successful, your Share certificate(s) will be issued in the name of HKSCC Nominees and deposited into CCASS for credit to your CCASS Investor Participant stock account or the stock account of your designated CCASS Participant as instructed by you in your Application Form at the close of business on December 16, 2009, or under contingent situation, on any other date as shall be determined by HKSCC or HKSCC Nominees.

If you are applying through a designated CCASS Participant (other than a CCASS Investor Participant):

- for Hong Kong Offer Shares credited to the stock account of your designated CCASS Participant (other than a CCASS Investor Participant), you can check the number of Hong Kong Offer Shares allocated to you with that CCASS Participant.

If you are applying as a CCASS Investor Participant:

- our Company expects to publish the results of CCASS Investor Participants' applications together with the results of the Hong Kong Public Offering on December 16, 2009. You should check the results made available by our Company and report any discrepancies to HKSCC or HKSCC Nominees before 5:00 p.m. on December 16, 2009 or such other date as shall be determined by HKSCC or HKSCC Nominees. Immediately after the credit of the Hong Kong Offer Shares to your stock account, you can check your new account balance via the CCASS Phone System and the CCASS Internet System (under the procedures contained in HKSCC's "An Operating Guide for Investor Participants" in effect from time to time). HKSCC will also make available to you an activity statement showing the number of Hong Kong Offer Shares credited to your stock account.

(c) If you apply by giving electronic application instruction to HKSCC

- No receipt will be issued for application money paid.
- If your application is wholly or partly successful, your Share certificates will be issued in the name of HKSCC Nominees and deposited into CCASS for the credit of your CCASS

---

## HOW TO APPLY FOR HONG KONG OFFER SHARES

---

Investor Participant stock account or the stock account of the CCASS Participant which you have instructed to give electronic application instructions on your behalf, at the close of business on December 16, 2009 or under contingent situation, on any other date HKSCC or HKSCC Nominees chooses.

- The Company will publish the application results of CCASS Participants (and where the CCASS Participant is a broker or custodian, the Company shall include information relating to the beneficial owner, if supplied), your Hong Kong Identity Card/passport number or other identification code (Hong Kong Business Registration number for corporations) and the basis of allotment of the Hong Kong Public Offering, in the South China Morning Post (in English) and Economic Times (in Chinese) on December 16, 2009. You should check the announcement published by the Company and report any discrepancies to HKSCC before 5:00 p.m. on December 16, 2009 or any other date HKSCC Nominees chooses.
- If you are instructing your broker or custodian to give electronic application instruction on your behalf, you can also check the number of Hong Kong Offer Shares allocated to you and the amount of refund (if any) payable to you with that broker or custodian.
- If you are applying as a CCASS Investor Participant, you can also check the number of Hong Kong Offer Shares allotted to you and the amount of refund (if any) payable to you via the CCASS Phone System and CCASS Internal System on December 16, 2009. Immediately following the credit of the Hong Kong Offer Shares to your stock account and credit of the refund monies to your bank account, HKSCC will make available to you an activity statement showing the number of Hong Kong Offer Shares credited to your stock account and the amount of refund money credited to your designated bank account (if any).
- The Company will not issue temporary documents of title.

### V. APPLYING BY USING WHITE FORM eIPO

#### 1. General

- (a) If you are an individual and meet the criteria set out above in “Who can apply for Hong Kong Offer Shares by means of White Form eIPO”, you may apply through **White Form eIPO** by submitting an application through designated website at [www.eipo.com.hk](http://www.eipo.com.hk). If you apply through **White Form eIPO** the Shares will be issued in your own name.
- (b) Detailed instructions for application through the **White Form eIPO** service are set out on the designated website at [www.eipo.com.hk](http://www.eipo.com.hk). You should read these instructions carefully. If you do not know the instructions, your application may be rejected by the designated White Form eIPO Service Provider and may not be submitted to our Company.
- (c) In addition to the terms and conditions set out in this prospectus, the designated White Form eIPO Service Provider may impose additional terms and conditions upon you for the use of the **White Form eIPO** service. Such terms and conditions are set out on the designated website at [www.eipo.com.hk](http://www.eipo.com.hk). You will be required to read, understand and agree to such terms and conditions in full prior to making any application.
- (d) By submitting an application to the designated White Form eIPO Service Provider through the **White Form eIPO** service ([www.eipo.com.hk](http://www.eipo.com.hk)), you are deemed to have authorized the designated White Form eIPO Service Provider to transfer the details of your application to our Company and our Hong Kong Share Registrar.

---

## HOW TO APPLY FOR HONG KONG OFFER SHARES

---

- (e) You may submit an application through the **White Form eIPO** service in respect of a minimum of 1,000 Hong Kong Offer Shares. Each electronic application instruction in respect of more than 1,000 Hong Kong Offer Shares must be in one of the numbers set out in the table in the Application Forms, or as otherwise specified on the designated website at [www.eipo.com.hk](http://www.eipo.com.hk).
- (f) You may submit your application to the designated White Form eIPO Service Provider through the designated website at [www.eipo.com.hk](http://www.eipo.com.hk) from 9:00 a.m. on December 4, 2009 until 11:30 a.m. on December 9, 2009 or such later time as described under the sub-paragraph headed “Effect of bad weather on the last application day” below (24 hours daily, except on the last application day). The latest time for completing full payment of application monies in respect of such applications will be 12:00 noon on December 9, 2009, the last application day, or, if the application lists are not open on that day, then by the time and date stated in the sub-paragraph headed “Effect of bad weather on the last application day” below.
- (g) You will not be permitted to submit your application to the designated White Form eIPO Service Provider through the designated website at [www.eipo.com.hk](http://www.eipo.com.hk) after 11:30 a.m. on the last day for submitting applications. If you have already submitted your application and obtained an application reference number from the website prior to 11:30 a.m., you will be permitted to continue the application process (by completing payment of application monies) until 12:00 noon on the last day for submitting applications, when the application lists close. If you do not make complete payment of the application monies (including any related fees) on or before 12:00 noon on December 9, 2009, or such later time as described under the sub-paragraph headed “Effects of bad weather on the last application day”, the designated White Form eIPO Service Provider will reject your application and your application monies will be returned to you in the manner described in the designated website at [www.eipo.com.hk](http://www.eipo.com.hk).

### 2. Effect of bad weather on the last application day

The latest time for submitting an application to the designated White Form eIPO Service Provider through the **White Form eIPO** service will be 11:30 a.m., and the latest time for completing full payment of application monies in respect of such applications will be 12:00 noon on December 9, 2009, the last application day. If:

- a tropical cyclone warning signal number 8 or above; or
- a ‘black’ rainstorm warning

in force in Hong Kong at any time between 9:00 a.m. and 12:00 noon on December 9, 2009, the last application day will be postponed to the next Business Day which does not have either of those warning signals in force in Hong Kong at any time between 9:00 a.m. and 12:00 noon on such day.

If the application lists of the Hong Kong Offer Shares do not open and close on December 9, 2009, or if there is a tropical cyclone warning signal number 8 or above or “black” rainstorm warning signal in force in Hong Kong on the other dates mentioned in the section headed “Expected Timetable”, such dates may be affected and an announcement will be made in such event.

### 3. Warning

The subscription of the Hong Kong Offer Shares through the **White Form eIPO** service ([www.eipo.com.hk](http://www.eipo.com.hk)) is only a facility provided by the designated White Form eIPO Service Provider to public investors. Our Company, our Directors, the Joint Sponsors, the Global Coordinator, the Hong

---

## HOW TO APPLY FOR HONG KONG OFFER SHARES

---

Kong Underwriters and any persons involved in the Global Offering take no responsibility for such applications, and provide no assurance that applications through the **White Form eIPO** service ([www.eipo.com.hk](http://www.eipo.com.hk)) will be submitted to our Company or that you will be allotted any Hong Kong Offer Shares.

### Environmental Protection

The obvious advantage of **White Form eIPO** is to save the use of papers via the self-serviced and electronic application process. Computershare Hong Kong Investor Services Limited, being the designated White Form eIPO Service Provider, will contribute HK\$2 per each “**MOBI Development Co., Ltd.**” **White Form eIPO** application submitted via [www.eipo.com.hk](http://www.eipo.com.hk) to support the funding of “Source of DongJiang — Hong Kong Forest” project initiated by Friends of the Earth (HK).

Please note that Internet services may have capacity limitations and/or be subject to service interruptions from time to time. To ensure that you can submit your applications through the **White Form eIPO** service ([www.eipo.com.hk](http://www.eipo.com.hk)), you are advised not to wait until the last day for submitting applications in the Hong Kong Public Offering to submit your application instructions. In the event that you have problems connecting to the designated website for the **White Form eIPO** service ([www.eipo.com.hk](http://www.eipo.com.hk)), you should submit a **White** Application Form. However, once you have submitted application instructions and completed payment in full using the application reference number provided to you on the designated website, you will be deemed to have made an actual application and should not submit a **White** Application Form. See “— How many applications you may make by means of White Form eIPO” below.

### 4. Additional information

For the purposes of allocating Hong Kong Offer Shares, each applicant giving application instructions through **White Form eIPO** service to the White Form eIPO Service Provider through the designated website at [www.eipo.com.hk](http://www.eipo.com.hk) will be treated as an applicant.

If your payment of application monies is insufficient, or in excess of the required amount, having regard to the number of Hong Kong Offer Shares for which you have applied, or if your application is otherwise rejected by the designated White Form eIPO Service Provider, the designated White Form eIPO Service Provider may adopt alternative arrangements for the refund of monies to you. Please refer to the additional information provided by the designated White Form eIPO Service Provider on the designated website at [www.eipo.com.hk](http://www.eipo.com.hk).

Otherwise, any monies payable to you due to a refund for any of the reasons set out below in the paragraph headed “Refund of application monies”.

### If you apply using White Form eIPO:

If you apply for 1,000,000 Hong Kong Offer Shares or more through the **White Form eIPO** service by submitting an application instruction to the designated White Form eIPO Service Provider through the designated website [www.eipo.com.hk](http://www.eipo.com.hk) and your application is wholly or partially successful, you may collect your Share certificate(s) (where applicable) in person from Computershare Hong Kong Investor Services Limited at Shops 1712-1716, 17th Floor, Hopewell Center, 183 Queen’s Road East, Wanchai, Hong Kong, from 9:00 a.m. to 1:00 p.m. on December 16, 2009, or such other date as notified by our Company in the South China Morning Post (in English) and Economic Times (in Chinese) as the date of dispatch/collection of Share certificates/e-Refund payment instructions/refund checks.

If you do not collect your Share certificate(s) personally within the time specified for collection, they will be sent to the address specified in your application instructions to the designated White Form eIPO Service Provider promptly thereafter by ordinary post and at your own risk.

---

## HOW TO APPLY FOR HONG KONG OFFER SHARES

---

If you apply for less than 1,000,000 Hong Kong Offer Shares, your Share certificate(s) (where applicable) will be sent to the address specified in your application instructions to the designated White Form eIPO Service Provider through the designated website [www.eipo.com.hk](http://www.eipo.com.hk) on December 16, 2009 by ordinary post and at your own risk.

If you paid the application monies from a single bank account and your application is wholly or partially unsuccessful and/or the Offer Price being different from the maximum offer price initially paid on your application, e-Refund payment instructions (if any) will be despatched to your application payment bank account on or around December 16, 2009.

If you used multi-bank accounts to pay the application monies and your application is wholly or partially unsuccessful and/or the Offer Price being different from the maximum offer price initially paid on your application, refund check(s) will be sent to the address specified in your application instructions to the designated White Form eIPO Service Provider on or around December 16, 2009, by ordinary post and at your own risk.

Please also note the additional information relating to refund of application monies overpaid, application monies underpaid or applications rejected by the designated White Form eIPO Service Provider set out above in the section headed “Applying by using White Form eIPO — Additional information”.

### VI. REFUND OF APPLICATION MONIES

Your application monies, or the appropriate portion thereof, together with the related brokerage of 1%, SFC transaction levy of 0.004%, and Stock Exchange trading fee of 0.005%, will be refunded if:

- your application is rejected, not accepted or accepted in part only or if you do not receive any Hong Kong Offer Shares for any of the reasons set out above in the paragraph headed “Circumstances in which you will not be allotted Hong Kong Offer Shares” of this section of the prospectus;
- the Offer Price as finally determined is less than the Offer Price of HK\$3.50 per share (excluding brokerage, SFC transaction levy and Stock Exchange trading fee thereon) initially paid on application;
- the conditions of the Hong Kong Public Offering are not fulfilled; or
- any application is revoked or any allotment pursuant thereto has become void.

No interest will be paid thereon. All interest accrued on such monies prior to the date of refund will be retained for our benefit.

In a contingency situation involving a substantial over-subscription, at the discretion of our Company and the Joint Bookrunners, checks for applications for certain small denominations of Hong Kong Offer Shares (apart from successful applications) may not be cleared.

Refund of your application monies (if any) will be made on December 16, 2009 in accordance with the various arrangements as described herein. It is intended that special efforts will be made to avoid any undue delay in refunding application monies where appropriate. Refund checks will be crossed “Account Payee Only” made out to you, or if you are joint applicants, to the first named applicant. Part of your Hong Kong identity card number or passport number, or, if you are joint applicants, part of the Hong Kong identity card number or passport number of the first-named applicant, provided by you may be printed on your refund check, if any. Such data will also be transferred to a third party for refund purposes. Your banker may require verification of your Hong

---

## HOW TO APPLY FOR HONG KONG OFFER SHARES

---

Kong identity card number or passport number before encashment of your refund check. Inaccurate citation of your Hong Kong identity card number or passport number may lead to delay in encashment of or may invalidate your refund check. It is intended that special efforts will be made to avoid any undue delay in refunding application monies where appropriate.

### VII. APPLYING BY GIVING ELECTRONIC APPLICATION INSTRUCTIONS TO HKSCC

#### 1. General

CCASS Participants may give electronic application instructions to HKSCC to apply for the Hong Kong Offer Shares and to arrange payment of the monies due on application and payment of refunds. This will be in accordance with their participant agreements with HKSCC and the General Rules of CCASS and the CCASS Operational Procedures in effect from time to time.

If you are a CCASS Investor Participant, you may give electronic application instructions through the CCASS Phone System by calling 2979 7888 or through the CCASS Internet System (<https://ip.ccass.com>) (using the procedures contained in HKSCC's "An Operating Guide for Investor Participants" in effect from time to time).

HKSCC can also input electronic application instructions for you if you go to:

**Hong Kong Securities Clearing Company Limited**  
Customer Service Center  
2/F Vicwood Plaza  
199 Des Voeux Road  
Central  
Hong Kong

and complete an input request form.

Prospectuses are available for collection from the above address.

If you are not a CCASS Investor Participant, you may instruct your broker or custodian who is a CCASS Clearing Participant or a CCASS Custodian Participant to give **electronic application instructions** via CCASS terminals to apply for the Hong Kong Offer Shares on your behalf.

You are deemed to have authorized HKSCC and/or HKSCC Nominees to transfer the details of your application, whether submitted by you or through your broker or custodian, to our Company and its Hong Kong Share Registrar.

#### 2. Giving electronic application instructions to HKSCC to apply for Hong Kong Offer Shares by HKSCC Nominees on your behalf

Where a **White** Application Form is signed by HKSCC Nominees on behalf of persons who have given **electronic application instructions** to apply for the Hong Kong Offer Shares:

- (i) HKSCC Nominees is only acting as a nominee for those persons and shall not be liable for any breach of the terms and conditions of the **White** Application Form or this prospectus;
- (ii) HKSCC Nominees does the following things on behalf of each such person:
  - agrees that the Hong Kong Offer Shares to be allotted shall be issued in the name of HKSCC Nominees and deposited directly into CCASS for the credit of the stock account of the CCASS Participant who has inputted **electronic application instructions** on that person's behalf or that person's CCASS Investor Participant stock account;
  - undertakes and agrees to accept the Hong Kong Offer Shares with respect to which that person has given **electronic application instructions** or any lesser number;

---

## HOW TO APPLY FOR HONG KONG OFFER SHARES

---

- undertakes and confirms that that person has not applied for or taken up any Offer Shares under the International Placing nor otherwise participated in the International Placing;
- (if the **electronic application instructions** are given for that person's own benefit) declares that only one set of **electronic application instructions** has been given for that person's benefit;
- (if that person is an agent for another person) declares that that person has only given one set of **electronic application instructions** for the benefit of that other person and that that person is duly authorized to give those instructions as that other person's agent;
- understands that the above declaration will be relied upon by our Company, our Directors, the Joint Sponsors, the Global Coordinator (for itself and on behalf of the Hong Kong Underwriters) in deciding whether or not to make any allotment of the Hong Kong Offer Shares in respect of the **electronic application instructions** given by that person and that that person may be prosecuted if he makes a false declaration;
- authorizes our Company to place the name of HKSCC Nominees on the register of members of our Company as the holder of the Hong Kong Offer Shares allotted in respect of that person's **electronic application instructions** and to send share certificate(s) and/or refund monies in accordance with the arrangements separately agreed between our Company and HKSCC;
- confirms that that person has read the terms and conditions and application procedures set out in this prospectus and agrees to be bound by them;
- confirms that that person has only relied on the information and representations in this prospectus in giving that person's **electronic application instructions** or instructing that person's broker or custodian to give **electronic application instructions** on that person's behalf and will not rely on any other information and representation;
- agrees that our Company, the Global Coordinator, the Joint Sponsors, the Underwriters and any of their representatives and the directors, officers, advisers are only liable for the information and representations contained in this prospectus and any supplement thereto;
- agrees to disclose that person's personal data to our Company and its Hong Kong Share Registrar, receiving bankers, the Global Coordinator, the Joint Sponsors, the Underwriters and any of their representatives, advisers and agents and any information which they may require about that person;
- agrees (without prejudice to any other rights which that person may have) that once the application of HKSCC Nominees is accepted, the application cannot be rescinded for innocent misrepresentation;
- agrees that any application made by HKSCC Nominees on behalf of that person pursuant to the **electronic application instructions** given by that person is irrevocable before the expiration of the fifth day after the closing of the application lists or such later date (excluding for this purpose any date which is a Saturday, Sunday or any public holiday in Hong Kong) as described under the sub-paragraph headed "Effect of bad weather on the opening of application lists" above, unless a person responsible for this prospectus under Section 40 of the Hong Kong Companies Ordinance (as applied by Section 342 E of the Hong Kong Companies Ordinance) gives a public notice under that section which excludes or limits the responsibility of that person for this prospectus;

---

## HOW TO APPLY FOR HONG KONG OFFER SHARES

---

- agrees that once the application of HKSCC Nominees is accepted, neither that application nor that person's **electronic application instructions** can be revoked, and that acceptance of that application will be evidenced by the results of the Hong Kong Public Offering made available by our Company;
- agrees to the arrangements, undertakings and warranties specified in the participant agreement between that person and HKSCC, read with the General Rules of CCASS and the CCASS Operational Procedures, in respect of the giving of **electronic application instructions** relating to the Hong Kong Offer Shares;
- agrees with our Company (for our Company itself and for the benefit of each shareholder of our Company) that Shares are freely transferable by the holders thereof; and
- agrees that that person's application, any acceptance of it and the resulting contract will be governed by and construed in accordance with the laws of Hong Kong.

### 3. Effect of giving electronic application instructions to HKSCC

By giving **electronic application instructions** to HKSCC or instructing your broker or custodian who is a CCASS Clearing Participant or a CCASS Custodian Participant to give such instructions to HKSCC, you (and if you are joint applicants, each of you jointly and severally) are deemed to have done the following things. Neither HKSCC nor HKSCC Nominees shall be liable to our Company or any other person in respect of the things mentioned below:

- instructed and authorized HKSCC to cause HKSCC Nominees (acting as nominee for the relevant CCASS Participant) to apply for the Hong Kong Offer Shares on your behalf;
- instructed and authorized HKSCC to arrange payment of the maximum Offer Price, brokerage, SFC transaction levy and Stock Exchange trading fee by debiting your designed bank account and, in the case of a wholly or partially unsuccessful application and/or the Offer Price is less than the initial price per Share paid on application, refund of the application monies, in each case including brokerage, SFC transaction levy and Stock Exchange trading fee, by crediting your designated bank account;
- instructed and authorized HKSCC to cause HKSCC Nominees to do on your behalf all the things which it is stated to do on your behalf in the **White** Application Form.

### 4. Multiple applications

If you are suspected of having made multiple applications or if more than one application is made for your benefit, the number of the Hong Kong Offer Shares applied for by HKSCC Nominees will be automatically reduced by the number of the Hong Kong Offer Shares in respect of which you have given such instructions and/or in respect of which such instructions have been given for your benefit. Any **electronic application instructions** to make an application for the Hong Kong Offer Shares given by you or for your benefit to HKSCC shall be deemed to be an actual application for the purpose of considering whether multiple applications have been made.

### 5. Minimum subscription amount and permitted numbers

You may give or cause your broker or custodian who is a CCASS Clearing Participant or a CCASS Custodian Participant to give **electronic application instructions** in respect of a minimum of 1,000 Hong Kong Offer Shares. Such instructions in respect of more than 1,000 Hong Kong Offer Shares must be in one of the numbers set out in the table in the Application Forms. No application for any other number of the Hong Kong Offer Shares will be considered and any such application is liable to be rejected.

---

## HOW TO APPLY FOR HONG KONG OFFER SHARES

---

### 6. Time for inputting electronic application instructions

CCASS Clearing/Custodian Participants can input **electronic application instructions** at the following times on the following dates:

**Friday, December 4, 2009 — 9:00 a.m. to 8:30 p.m.<sup>(1)</sup>**  
**Saturday, December 5, 2009 — 8:00 a.m. to 1:00 p.m.<sup>(1)</sup>**  
**Monday, December 7, 2009 — 8:00 a.m. to 8:30 p.m.<sup>(1)</sup>**  
**Tuesday, December 8, 2009 — 8:00 a.m. to 8:30 p.m.<sup>(1)</sup>**  
**Wednesday, December 9, 2009 — 8:00 a.m.<sup>(1)</sup> to 12:00 noon**

*Note:*

- (1) These times are subject to change as HKSCC may determine from time to time with prior notification to CCASS Clearing/Custodian Participants.

CCASS Investor Participants can input electronic application instructions from 9:00 a.m. on December 4, 2009 until 12:00 noon on December 9, 2009 (24 hours daily, except the last application day).

### 7. Effect of bad weather on the last application day

The latest time for inputting your electronic application instructions will be 12:00 noon, December 9, 2009, if:

- a tropical cyclone warning signal number 8 or above, or
- a “black” rainstorm warning signal

is in force in Hong Kong at any time between 9:00 a.m. and 12:00 noon, December 9, 2009, the last application day will be postponed to the next Business Day which does not have either of those warning signals in force in Hong Kong at any time between 9:00 a.m. to 12:00 noon on such day.

If the application of the Hong Kong Offer Shares do not open and close on December 9, 2009, or if there is a tropical cyclone warning signal number 8 or above or “black” rainstorm warning signal in force in Hong Kong on the other dates mentioned in the section headed “Expected Timetable”, such dates may be affected and an announcement will be made in such event.

### 8. Allocation of Hong Kong Offer Shares

For the purpose of allocating the Hong Kong Offer Shares, HKSCC Nominees will not be treated as an applicant. Instead, each CCASS Participant who gives **electronic application instructions** or each person for whose benefit each such instructions is given will be treated as an applicant.

### 9. Section 40 of the Companies Ordinance

For the avoidance of doubt, our Company and all other parties involved in the preparation of this prospectus acknowledge that each CCASS Participant who gives or causes to give **electronic application instructions** is a person who may be entitled to compensation under section 40 of the Companies Ordinance.

### 10. Personal data

The section of the Application Forms headed “Personal data” applies to any personal data held by our Company and the Hong Kong Share Registrar about you in the same way as it applies to personal data about applicants other than HKSCC Nominees.

---

## HOW TO APPLY FOR HONG KONG OFFER SHARES

---

### 11. Warning

The subscription of the Hong Kong Offer Shares by giving **electronic application instructions** to HKSCC is only a facility provided to CCASS Participants. Our Company, our Directors, the Joint Sponsors, the Global Coordinator, the Hong Kong Underwriters and any persons involved in the Global Offering take no responsibility for the application and provide no assurance that any CCASS Participant will be allotted any Hong Kong Offer Shares.

To ensure that CCASS Investor Participants can give their **electronic application instructions** to HKSCC through the CCASS Phone System or the CCASS Internet System, CCASS Investor Participants are advised not to wait until the last minute to input their **electronic application instructions** to the systems. In the event that CCASS Investor Participants have problems connecting to CCASS Phone System or the CCASS Internet System to submit their **electronic application instructions**, they should either (a) submit a **White** or **Yellow** Application Form; or (b) go to HKSCC's Customer Service Centre to complete an input request form for **electronic application instructions** before 12:00 noon on December 9, 2009 or such later date as stated in the sub-paragraph headed "Effect of bad weather on the opening of the application lists" above.

### VIII. HOW MANY APPLICATIONS YOU CAN MAKE

- (a) You may make more than one application for the Hong Kong Offer Shares only if:
- You are a nominee, in which case you may make an application as a nominee by: (i) giving **electronic application instructions** to HKSCC via CCASS (if you are a CCASS Participant) or (ii) using a **White** or **Yellow** Application Form and lodging more than one application in your own name on behalf of different beneficial owners. In the box on the **White** or **Yellow** Application Form marked "For nominees" you must include:
    - an account number; or
    - some other identification code for each beneficial owner (or, in the case of joint beneficial owners, for each such joint beneficial owner). If you do not include this information, the application will be treated as being made for your own benefit.
- (b) All of your applications for the Hong Kong Offer Shares (including the part of the application made by HKSCC Nominees Limited acting on **electronic application instructions**) will be rejected as multiple applications if you, or you and your joint applicant(s) together or any of your joint applicants:
- make more than one application (whether individually or jointly with others) on **White** or **Yellow** Application Form or by giving **electronic application instructions** to HKSCC via CCASS (if you are a CCASS Investor Participant or applying through a CCASS Clearing or Custodian Participant) or to the designated White Form eIPO Service Provider through White Form eIPO service ([www.eipo.com.hk](http://www.eipo.com.hk)); or
  - both apply (whether individually or jointly with others) on one (or more) **White** Application Form and one (or more) **Yellow** Application Form or on one (or more) **White** or **Yellow** Application Form and give **electronic application instructions** to HKSCC via CCASS or to the designated White Form eIPO Service Provider through **White Form eIPO** service ([www.eipo.com.hk](http://www.eipo.com.hk)); or

---

## HOW TO APPLY FOR HONG KONG OFFER SHARES

---

- apply (whether individually or jointly with others) on one (or more) **White** or **Yellow** Application Form or by giving **electronic application instructions** to HKSCC via CCASS (if you are a CCASS Investor Participant or applying through a CCASS Clearing or Custodian Participant) or to the designated White Form eIPO Service Provider through **White Form eIPO** service ([www.eipo.com.hk](http://www.eipo.com.hk)) for more than 50% of the Hong Kong Offer Shares being initially available for subscription under the Hong Kong Public Offering; or
  - have applied for or taken up, or indicated an interest in applying for or taking up or have been or will be placed (including conditionally and/or provisionally) any International Placing Shares under the International Placing.
- (c) All of your applications for the Hong Kong Offer Shares are liable to be rejected as multiple applications if more than one application is made for your benefit (including the part of the application made by HKSCC Nominees Limited acting on **electronic application instructions**). If an application is made by an unlisted company and:
- (i) the only business of that company is dealing in securities; and
  - (ii) you exercise statutory control over that company, then the application will be deemed to be made for your benefit.

*Unlisted company means a company with no equity securities listed on the Stock Exchange.*

*Statutory control in relation to a company means you:*

- (i) control the composition of the board of directors of that company; or
- (ii) control more than half of the voting power of that company; or
- (iii) hold more than half of the issued share capital of that company (not counting any part of it which carries no right to participate beyond a specified amount in a distribution of either profits or capital).

### **How many applications you may make by means of White Form eIPO**

If you apply by means of **White Form eIPO**, once you complete payment in respect of any electronic application instruction given by you or for your benefit to the designated White Form eIPO Service Provider to make an application for Hong Kong Offer Shares, an actual application shall be deemed to have been made. For the avoidance of doubt, giving an electronic application instruction under **White Form eIPO** more than once and obtaining different application reference numbers without effecting full payment in respect of a particular reference number will not constitute an actual application.

If you are suspected of submitting more than one application through the **White Form eIPO** service by giving electronic application instructions through the designated website at [www.eipo.com.hk](http://www.eipo.com.hk) and completing payment in respect of such electronic application instructions, or of submitting one application through the **White Form eIPO** service and one or more applications by any other means, all of your applications are liable to be rejected.

---

## HOW TO APPLY FOR HONG KONG OFFER SHARES

---

### IX. CIRCUMSTANCES IN WHICH YOU WILL NOT BE ALLOTTED THE HONG KONG OFFER SHARES

Full details of the circumstances in which you will not be allotted Hong Kong Offer Shares are set out in the notes attached to the Application Forms (whether you are making your application by an Application Form or electronically instructing HKSCC Nominees to apply on your behalf), and you should read them carefully. You should note in particular the following two situations in which the Hong Kong Offer Shares will not be allotted to you:

- **If your application is revoked:**

By completing and submitting an Application Form or giving **electronic application instructions** to HKSCC or to the designated White Form eIPO Service Provider through **White Form eIPO** service ([www.eipo.com.hk](http://www.eipo.com.hk)), you agree that your application or the application made by HKSCC Nominees on your behalf is irrevocable before expiration of the fifth day after the closing of the application lists. This agreement will take effect as a collateral contract with our Company, and will become binding when you lodge your Application Form or give your **electronic application instructions** to HKSCC or to the designated White Form eIPO Service Provider through **White Form eIPO** service ([www.eipo.com.hk](http://www.eipo.com.hk)) and an application has been made by HKSCC Nominees on your behalf accordingly. This collateral contract will be in consideration of our Company agreeing that it will not offer any Hong Kong Offer Shares to any person on or before December 16, 2009 except by means of one of the procedures referred to in this prospectus.

Your application or the application made by HKSCC Nominees on your behalf may only be revoked on or before December 16, 2009 if a person responsible for this prospectus under section 40 of the Companies Ordinance gives a public notice under that section which excludes or limits the responsibility of that person for this prospectus. If any supplement to this prospectus is issued, applicant(s) who have already submitted an application may or may not (depending on the information contained in the supplement) be notified that they can withdraw their applications. If applicant(s) have not been so notified, or if applicant(s) have been notified but have not withdrawn their applications in accordance with the procedure to be notified, all applications that have been submitted remain valid and may be accepted. Subject to the above, an application once made is irrevocable and applicants shall be deemed to have applied on the basis of this prospectus as supplemented.

If your application or the application made by HKSCC Nominees on your behalf has been accepted, it cannot be revoked. For this purpose, acceptance of applications which are not rejected will be constituted by notification of the results of allotment in the manner as described in section headed “How to apply for Hong Kong Offer Shares — Publication of results” in this prospectus, and where such basis of allotment is subject to certain conditions or provides for allocation by ballot, such acceptance will be subject to the satisfaction of such conditions or results of the ballot respectively.

- **At the discretion of our Company or its agents or nominees, your application is rejected:**

Our Company, the Global Coordinator (on behalf of our Company) or the designated White Form eIPO Service Provider (where applicable) or their respective agents or nominees have full discretion to reject or accept any application, or to accept only part of any application. Our Company, the Global Coordinator (on behalf of our Company) or the designated White Form eIPO Service Provider (where applicable) or their respective agents or nominees do not have to give any reason for any rejection or acceptance.

---

## HOW TO APPLY FOR HONG KONG OFFER SHARES

---

- **If the allotment of the Hong Kong Offer Shares is void:**

The allotment of the Hong Kong Offer Shares to you or to HKSCC Nominees (if you give electronic application instruction or apply by a yellow Application Form) will be void if the Listing Committee of the Stock Exchange does not grant permission to list the Shares in issue and to be issued as mentioned in this prospectus either:

- within three weeks from the closing of the application lists in respect of the Hong Kong Public Offering; or
- within a longer period of up to six weeks if the Listing Committee of the Stock Exchange notifies our Company of that longer period within three weeks of the closing of the application lists in respect of the Hong Kong Public Offering.

- **Your application is rejected:**

Your application will be rejected if

- it is a multiple or suspected multiple application;
- your Application Form is not completed correctly in accordance with the instructions therein;
- your **electronic application instructions** through the **White Form eIPO** are not completed in accordance with the instructions, terms and conditions set out in the designated website at [www.eipo.com.hk](http://www.eipo.com.hk);
- you or the person(s) for whose benefit you are applying have applied for and/or been allotted or will be allotted with the International Placing Shares;
- your payment is not in the correct form;
- you pay by check or banker's cashier order and the check or banker's cashier order is dishonoured on its first presentation;
- our Company and the Global Coordinator (on behalf of our Company) believe that the acceptance of your application would violate the applicable securities or other laws, rules or regulation of the jurisdiction in which your application is completed and/or signed or your address appeared in the application is located;
- your application is for more than 50% of the Hong Kong Offer Shares initially available for subscription under the Hong Kong Public Offering; or
- any of the Underwriting Agreements does not become unconditional in accordance with its terms or is terminated in accordance with its terms.

## X. COMMENCEMENT OF DEALINGS IN THE SHARES

Dealings in the Shares are expected to commence at 9:30 a.m. on December 17, 2009.

The Shares will be traded in board lots of 1,000 Shares each.

The Stock Exchange stock code for the Shares is 947.

---

## HOW TO APPLY FOR HONG KONG OFFER SHARES

---

### **XI. SHARES WILL BE ELIGIBLE FOR ADMISSION INTO CCASS**

If the Stock Exchange grants approval of the listing of and permission to deal in the Shares in issue and to be issued as mentioned in this prospectus and our Company complies with the stock admission requirements of HKSCC, the Shares will be accepted as eligible securities by HKSCC for deposit, clearance and settlement in CCASS with effect from the date of commencement of dealings in the Shares on the Stock Exchange or on any other date HKSCC chooses. Settlement of transactions between participants of the Stock Exchange is required to take place in CCASS on the second Business Day after any trading day.

All activities under CCASS are subject to the General Rules of CCASS and CCASS Operational Procedures in effect from time to time. All necessary arrangements have been made for the Shares to be admitted into CCASS.

# Deloitte.

## 德勤

德勤·關黃陳方會計師行  
香港金鐘道88號  
太古廣場一座35樓

Deloitte Touche Tohmatsu  
35/F One Pacific Place  
88 Queensway  
Hong Kong

4th December 2009

The Directors  
MOBI Development Co., Ltd.  
Piper Jaffray Asia Limited  
First Shanghai Capital Limited

Dear Sirs,

We set out below our report on the financial information (the “Financial Information”) regarding MOBI Development Co., Ltd. (the “Company”) and its subsidiaries (hereinafter collectively referred to as the “Group”) for each of the three years ended 31st December 2008 and eight months ended 31st August 2009 (the “Relevant Periods”), for inclusion in the prospectus of the Company dated 4th December 2009 (the “Prospectus”) in connection with the proposed listing of the Company’s shares on the Main Board of The Stock Exchange of Hong Kong Limited.

The Company was incorporated as an exempted company and registered in the Cayman Islands with limited liability under the Companies Law of the Cayman Islands on 16th December 2002.

As at the date of this report, the particulars of the Company’s subsidiaries are as follows:

Name of subsidiary	Place and date of establishment	Issued and fully paid registered capital	Equity interest attributable to the Group				Principal activities	
			Date					
			At 31st December 2006	2007	2008	August 2009		
摩比天線技術(深圳)有限公司 MOBI Antenna Technologies (Shenzhen) Co., Ltd. (“MOBI Shenzhen”) (1)	The People’s Republic of China (the “PRC”) 12th August 1999	RMB30,000,000	100%	100%	100%	100%	100%	Production and sale of antennas and radio frequency subsystems
摩比通訊技術(吉安)有限公司 MOBI Telecommunication Technologies (Ji An) Co., Ltd. (“MOBI Jian”) (1)	PRC 23rd May 2006	RMB3,000,000	100%	100%	100%	100%	100%	Production and sale of antennas and radio frequency subsystems
摩比科技(西安)有限公司 MOBI Technologies (Xi An) Co., Ltd. (“MOBI Xian”)	PRC 29th April 2008	RMB24,000,000	—	—	100%	100%	100%	Production and sale of antennas and radio frequency subsystems

(1) MOBI Shenzhen and MOBI Jian are directly held by the Company.

The statutory financial statements of MOBI Shenzhen, MOBI Jian and MOBI Xian were prepared under accounting principles and practices generally accepted in the PRC and were audited by the following certified public accountants registered in PRC.

<b>Name of subsidiary</b>	<b>Financial period</b>	<b>Auditors</b>
MOBI Shenzhen	Each of the three years ended 31st December 2008	Deloitte Touche Tohmatsu CPA Ltd. Shenzhen Branch
MOBI Jian	For the period from 23rd May 2006 (date of establishment) to 31st December 2006	Deloitte Touche Tohmatsu CPA Ltd. Shenzhen Branch
	Each of the two years ended 31st December 2008	
MOBI Xian	For the period from 29th April 2008 (date of establishment) to 31st December 2008	Deloitte Touche Tohmatsu CPA Ltd. Shenzhen Branch

Deloitte Touche Tohmatsu CPA Ltd. Shenzhen Branch has audited the financial statements of the Group for the Relevant Periods which are prepared in accordance with Hong Kong Financial Reporting Standards (the "Underlying Financial Statements") with Hong Kong Standards on Auditing issued by the Hong Kong Institute of Certified Public Accountants ("HKICPA") and we have examined the Underlying Financial Statements in accordance with the Auditing Guideline 3.340 "Prospectuses and the Reporting Accountant" as recommended by the HKICPA.

The consolidated statements of financial position of the Group as at 31st December 2006, 31st December 2007, 31st December 2008 and 31st August 2009 and the consolidated statements of comprehensive income and consolidated statements of cash flows of the Group for the Relevant Periods have been prepared from the Underlying Financial Statements and no adjustments to the Underlying Financial Statements are considered necessary in the preparation of this report for inclusion in the Prospectus.

The Underlying Financial Statements are the responsibility of the directors of the Company who approved their issues. The directors of the Company are responsible for the contents of the Prospectus in which this report is included. It is our responsibility to compile the Financial Information set out in this report from the Underlying Financial Statements, to form an independent opinion on the Financial Information and to report our opinion to you.

In our opinion, the Financial Information gives, for the purpose of this report, a true and fair view of the state of affairs of the Group and the Company as at 31st December 2006, 31st December 2007, 31st December 2008 and 31st August 2009 and of the consolidated profits and cash flows of the Group for the Relevant Periods.

The comparative consolidated statement of comprehensive income, consolidated statement of cash flows and consolidated statement of changes in equity of the Group for the eight months ended 31st August 2008 together with the notes thereon have been extracted from the Group's consolidated financial information for the same period (the "31st August 2008 Financial Information") which was prepared by the directors of the Company solely for the purpose of this report. We have reviewed the 31st August 2008 Financial Information in accordance with the Hong Kong Standard on Review Engagements 2410 "Review of Interim Financial Information Performed by Independent Auditor of

the Entity” issued by the HKICPA. Our review consists principally of making enquiries of the Group’s management and applying analytical and other review procedures to the 31st August 2008 Financial Information and based thereon, assessing whether the accounting policies and presentation have been consistently applied unless otherwise disclosed. A review excludes audit procedures such as tests of controls and verification of assets, liabilities and transactions. It is substantially less in scope than an audit and therefore provides a lower level of assurance than an audit. Accordingly, we do not express an audit opinion on the 31st August 2008 Financial Information. Base on our review, nothing has come to our attention that causes us to believe that the 31st August 2008 Financial Information is not prepared, in all material respects, in accordance with the accounting policies consistent with those used in the preparation of the Financial Information which conform with Hong Kong Financial Reporting Standards.

#### A. CONSOLIDATED STATEMENTS OF COMPREHENSIVE INCOME

	<i>Section E Notes</i>	<b>Year ended 31st December</b>			<b>Eight months ended 31st August</b>	
		<b>2006</b>	<b>2007</b>	<b>2008</b>	<b>2008</b>	<b>2009</b>
		<i>RMB'000</i>	<i>RMB'000</i>	<i>RMB'000</i>	<i>RMB'000</i>	<i>RMB'000</i>
					<i>(unaudited)</i>	
Revenue	7	360,956	626,806	671,182	426,438	632,367
Cost of sales		(275,888)	(472,674)	(487,884)	(312,593)	(451,873)
Gross profit		85,068	154,132	183,298	113,845	180,494
Other income	8	3,741	2,943	7,103	3,647	3,610
Research and development costs		(15,171)	(24,945)	(34,550)	(21,654)	(21,305)
Distribution and selling expenses		(19,223)	(27,875)	(35,170)	(17,606)	(32,055)
Administrative expenses		(20,762)	(41,819)	(47,401)	(31,766)	(31,181)
Finance costs	9	(153)	(2,899)	(3,803)	(2,932)	(2,664)
Profit before taxation		33,500	59,537	69,477	43,534	96,899
Income tax expense	10	(2,019)	(2,764)	(7,552)	(6,186)	(12,694)
Profit and the total comprehensive income for the year/period and attributable to owners of the Company	11	<u>31,481</u>	<u>56,773</u>	<u>61,925</u>	<u>37,348</u>	<u>84,205</u>
Earnings per share						
- basic	14	<u>7.91 cents</u>	<u>15.21 cents</u>	<u>15.41 cents</u>	<u>8.83 cents</u>	<u>21.38 cents</u>
- diluted	14	<u>5.99 cents</u>	<u>10.62 cents</u>	<u>11.60 cents</u>	<u>6.93 cents</u>	<u>15.50 cents</u>

## B. STATEMENTS OF FINANCIAL POSITION

	Section E Notes	The Group				The Company			
		At 31st December			At 31st August	At 31st December			At 31st August
		2006	2007	2008	2009	2006	2007	2008	2009
	RMB'000	RMB'000	RMB'000	RMB'000	RMB'000	RMB'000	RMB'000	RMB'000	
Non-current assets									
Property, plant and equipment	15	70,253	89,029	107,484	117,711	—	—	—	—
Prepaid lease payments	16	4,324	4,233	21,570	21,303	—	—	—	—
Investments in subsidiaries	17	—	—	—	—	30,599	31,492	32,294	32,785
Deferred tax assets	18	—	1,527	6,000	7,384	—	—	—	—
		<u>74,577</u>	<u>94,789</u>	<u>135,054</u>	<u>146,398</u>	<u>30,599</u>	<u>31,492</u>	<u>32,294</u>	<u>32,785</u>
Current assets									
Inventories	19	51,808	127,442	222,049	290,767	—	—	—	—
Trade and other receivables	20	205,882	280,747	362,159	513,902	—	3,444	5,586	5,584
Amount due from a subsidiary	17	—	—	—	—	—	1,839	900	900
Prepaid lease payments	16	98	98	471	453	—	—	—	—
Pledged bank balances	21	1,308	8,006	14,739	41,592	—	—	—	—
Bank balances and cash	21	43,080	131,470	59,067	69,203	16,593	11,960	9,675	8,718
		<u>302,176</u>	<u>547,763</u>	<u>658,485</u>	<u>915,917</u>	<u>16,593</u>	<u>17,243</u>	<u>16,161</u>	<u>15,202</u>
Current liabilities									
Trade and other payables	22	153,327	281,500	380,311	490,370	2	4,447	4,153	3,864
Dividend payable		—	—	429	758	—	—	429	758
Tax payable		495	2,404	8,033	11,325	—	—	—	—
Entrusted loan	21	—	5,000	—	—	—	—	—	—
Short-term bank borrowings	23	7,909	69,500	73,454	157,744	—	—	—	—
Deferred income	24	54	563	563	746	—	—	—	—
Provision	25	500	500	500	500	—	—	—	—
		<u>162,285</u>	<u>359,467</u>	<u>463,290</u>	<u>661,443</u>	<u>2</u>	<u>4,447</u>	<u>4,582</u>	<u>4,622</u>
Net current assets		<u>139,891</u>	<u>188,296</u>	<u>195,195</u>	<u>254,474</u>	<u>16,591</u>	<u>12,796</u>	<u>11,579</u>	<u>10,580</u>
Total assets less current liabilities		<u>214,468</u>	<u>283,085</u>	<u>330,249</u>	<u>400,872</u>	<u>47,190</u>	<u>44,288</u>	<u>43,873</u>	<u>43,365</u>
Non-current liabilities									
Deferred income	24	1,297	3,236	2,673	3,600	—	—	—	—
Net assets		<u>213,171</u>	<u>279,849</u>	<u>327,576</u>	<u>397,272</u>	<u>47,190</u>	<u>44,288</u>	<u>43,873</u>	<u>43,365</u>
Capital and reserves									
Issued capital	26	1	1	1	1	1	1	1	1
Reserves		<u>213,170</u>	<u>279,848</u>	<u>327,575</u>	<u>397,271</u>	<u>47,189</u>	<u>44,287</u>	<u>43,872</u>	<u>43,364</u>
Equity attributable to owners of the Company		<u>213,171</u>	<u>279,849</u>	<u>327,576</u>	<u>397,272</u>	<u>47,190</u>	<u>44,288</u>	<u>43,873</u>	<u>43,365</u>

## C. STATEMENTS OF CHANGES IN EQUITY

## The Group

	Issued capital	Share premium	Enterprise expansion fund	Statutory surplus reserve fund	Special reserve	Share option reserve (Section E Note 27)	Retained profits	Total
	RMB'000	RMB'000	RMB'000	RMB'000	RMB'000	RMB'000	RMB'000	RMB'000
At 1st January 2006	1	43,042	1,682	—	2,999	2,225	138,175	188,124
Profit and the total comprehensive income for the year	—	—	—	—	—	—	31,481	31,481
Recognition of equity-settled share-based payment	—	—	—	—	—	1,531	—	1,531
Transfers	—	—	1,352	6,500	—	—	(7,852)	—
Dividends paid	—	—	—	—	—	—	(7,965)	(7,965)
At 31st December 2006	1	43,042	3,034	6,500	2,999	3,756	153,839	213,171
Issue of shares upon exercise of warrants	—	9,000	—	—	—	—	—	9,000
Profit and the total comprehensive income for the year	—	—	—	—	—	—	56,773	56,773
Recognition of equity-settled share-based payment	—	—	—	—	—	905	—	905
Transfers	—	—	—	7,664	—	—	(7,664)	—
At 31st December 2007	1	52,042	3,034	14,164	2,999	4,661	202,948	279,849
Profit and the total comprehensive income for the year	—	—	—	—	—	—	61,925	61,925
Recognition of equity-settled share-based payment	—	—	—	—	—	802	—	802
Transfers	—	—	—	2,336	—	—	(2,336)	—
Dividends paid	—	(12,695)	—	—	—	—	(2,305)	(15,000)
At 31st December 2008	1	39,347	3,034	16,500	2,999	5,463	260,232	327,576
Profit and the total comprehensive income for the period	—	—	—	—	—	—	84,205	84,205
Recognition of equity-settled share-based payment	—	—	—	—	—	491	—	491
Dividends paid	—	(851)	—	—	—	—	(14,149)	(15,000)
At 31st August 2009	1	38,496	3,034	16,500	2,999	5,954	330,288	397,272
At 1st January 2008	1	52,042	3,034	14,164	2,999	4,661	202,948	279,849
Profit and the total comprehensive income for the period	—	—	—	—	—	—	37,348	37,348
Recognition of equity-settled share-based payment	—	—	—	—	—	556	—	556
Dividends paid	—	(12,695)	—	—	—	—	(2,305)	(15,000)
At 31st August 2008 (unaudited)	1	39,347	3,034	14,164	2,999	5,217	237,991	302,753

As stipulated by the relevant laws and regulations for foreign investment enterprises in the PRC, the Company's PRC subsidiaries are required to maintain two statutory reserves, being an enterprise expansion fund and a statutory surplus reserve fund which are non-distributable. Appropriations to such reserves are made out of net profit after taxation reported in the statutory financial statements of the PRC subsidiaries while the amounts and allocation basis are decided by their board of directors annually. The statutory surplus reserve fund can be used to make up their prior year losses, if any, and can be applied in conversion into capital by means of capitalisation issue. The enterprise expansion fund is used for expanding the capital base of the PRC subsidiaries by means of capitalisation issue.

Under the Companies Law of the Cayman Islands and in accordance with the Articles, the Company is permitted to pay dividend out of its share premium and its retained profits. During the Relevant Periods, dividends, to the extent in excess of the Company's retained profits, were funded out of its share premium.

Special reserve represents the difference between the paid-in capital of MOBI Shenzhen acquired pursuant to the group restructuring, completed on 19th December 2002, at which time the Company entered into an equity transfer agreement for the acquisition of the entire equity interest in MOBI Shenzhen, and the nominal value of the Company's shares issued in connection with the acquisition.

### The Company

	Issued capital <i>RMB'000</i>	Share premium <i>RMB'000</i>	Share option reserve (Section E Note 27) <i>RMB'000</i>	(Accumulated loss) Retained profits <i>RMB'000</i>	Total <i>RMB'000</i>
At 1st January 2006	1	43,042	2,225	(230)	45,038
Profit and the total comprehensive income for the year	—	—	—	8,586	8,586
Recognition of equity-settled share-based payment	—	—	1,531	—	1,531
Dividends paid	—	—	—	(7,965)	(7,965)
At 31st December 2006	1	43,042	3,756	391	47,190
Issue of shares upon exercise of warrants	—	9,000	—	—	9,000
Loss and the total comprehensive expenses for the year	—	—	—	(12,807)	(12,807)
Recognition of equity-settled share-based payment	—	—	905	—	905
At 31st December 2007	1	52,042	4,661	(12,416)	44,288
Profit and the total comprehensive income for the year	—	—	—	13,783	13,783
Recognition of equity-settled share-based payment	—	—	802	—	802
Dividends paid	—	(12,695)	—	(2,305)	(15,000)
At 31st December 2008	1	39,347	5,463	(938)	43,873
Profit and the total comprehensive income for the period	—	—	—	14,001	14,001
Recognition of equity-settled share-based payment	—	—	491	—	491
Dividends paid	—	(851)	—	(14,149)	(15,000)
At 31st August 2009	1	38,496	5,954	(1,086)	43,365

## D. CONSOLIDATED STATEMENTS OF CASH FLOWS

	Year ended 31st December			Eight months ended 31st August	
	2006 RMB'000	2007 RMB'000	2008 RMB'000	2008 RMB'000	2009 RMB'000
Operating activities					
Profit before taxation	33,500	59,537	69,477	43,534	96,899
Adjustments for:					
Equity-settled share-based payment expenses	1,531	905	802	556	491
Depreciation	5,556	9,920	13,471	8,564	9,910
(Reversals of) allowance for doubtful debts	(192)	782	452	452	—
Write-down of inventories	1,130	1	361	200	721
Government grants related to assets	(18)	(112)	(563)	(373)	(920)
Interest income	(810)	(751)	(880)	(457)	(190)
Release of prepaid lease payments	79	91	372	61	285
Loss (gain) on disposal of property, plant and equipment	3	1	(6)	(8)	86
Finance cost	153	2,899	3,803	2,932	2,664
Operating cash flows before movements in working capital	40,932	73,273	87,289	55,461	109,946
Decrease (increase) in inventories	1,422	(75,635)	(94,968)	(74,295)	(69,439)
Increase in trade and other receivables	(81,577)	(75,647)	(81,864)	(40,622)	(151,743)
Increase in trade and other payables	45,590	135,773	99,286	105,011	111,961
Increase in provision	500	—	—	—	—
Cash from operations	6,867	57,764	9,743	45,555	725
Taxation paid	(1,373)	(2,382)	(6,396)	(4,324)	(10,786)
Net cash from (used in) operating activities	5,494	55,382	3,347	41,231	(10,061)
Investing activities					
Interest received	810	751	880	457	190
Government grant related to assets	3,997	924	—	—	1,038
Decrease (increase) in pledged bank balances	5,481	(6,698)	(6,733)	(15,408)	(26,853)
Prepaid lease payments	(1,284)	—	(18,082)	—	—
Purchase of property, plant and equipment	(40,946)	(34,675)	(32,442)	(18,998)	(21,180)
Proceeds on disposals of property, plant and equipment	4	14	47	41	47
Net cash used in investing activities	(31,938)	(39,684)	(56,330)	(33,908)	(46,758)
Financing activities					
Proceeds from shareholders for subscription of series A preferred shares and ordinary shares	—	9,000	—	—	—
Dividends paid	(7,965)	—	(14,571)	(14,571)	(14,671)
Net funds arisen from discounting notes receivable and trade receivables	7,909	16,591	(1,046)	(24,500)	12,155
New entrusted loan raised	—	5,000	—	—	—
Repayment of entrusted loan	—	—	(5,000)	(5,000)	—
New bank loans raised	—	50,000	100,000	75,000	122,135
Repayment of bank borrowings	—	(5,000)	(95,000)	(75,000)	(50,000)
Interest paid	(153)	(2,899)	(3,803)	(2,932)	(2,664)
Net cash (used in) from financing activities	(209)	72,692	(19,420)	(47,003)	66,955
(Decrease) increase in cash and cash equivalents	(26,653)	88,390	(72,403)	(39,680)	10,136
Cash and cash equivalents at 1st January	69,733	43,080	131,470	131,470	59,067
Cash and cash equivalents at end of the year/period, represented by bank balances and cash	43,080	131,470	59,067	91,790	69,203

**E. NOTES TO THE FINANCIAL INFORMATION****1. GENERAL AND BASIC OF PREPARATION OF FINANCIAL INFORMATION**

The Company is a limited liability company established in the Cayman Islands on 16th December 2002. The Company is an investment holding company. The principal activities of its subsidiaries are the production and sale of antennas and radio frequency subsystems. The address of its registered office and principal place of business is disclosed in the "Corporate Information" section to the Prospectus.

The Financial Information is presented in Renminbi ("RMB"), which is the same as the functional currency of the Company and its subsidiaries.

**2. APPLICATION OF NEW AND REVISED HONG KONG FINANCIAL REPORTING STANDARDS ("HKFRSS")**

The Group has adopted all the new and revised standards, amendments and interpretations (hereinafter collectively referred to as "New HKFRSs") issued by the HKICPA that are effective for the Group's financial year beginning on 1st January 2009. For the purposes of preparing and presenting the Financial Information of the Relevant Periods, the Group has consistently adopted all these New HKFRSs throughout the Relevant Periods.

At the date of this report, the HKICPA has issued the following new standards, amendments and interpretations that are not yet effective. The Group has not early adopted these new standards, amendments and interpretations.

HKFRSs (Amendments)	Amendment to HKFRS 5 as part of Improvements to HKFRSs 2008 <sup>1</sup>
HKFRSs (Amendments)	Improvements to HKFRSs 2009 <sup>2</sup>
HKAS 24 (Revised)	Related Party Disclosures <sup>3</sup>
HKAS 27 (Revised)	Consolidated and Separate Financial Statements <sup>1</sup>
HKAS 32 (Amendment)	Classification of Rights Issues <sup>4</sup>
HKAS 39 (Amendment)	Eligible Hedged Items <sup>1</sup>
HKFRS 1 (Amendment)	Additional Exemption for First-time Adopters <sup>5</sup>
HKFRS 2 (Amendment)	Group Cash-settled Share-based Payment Transactions <sup>5</sup>
HKFRS 3 (Revised)	Business Combinations <sup>1</sup>
HKFRS 9	Financial Instruments <sup>6</sup>
HK (IFRIC)-Int 17	Distributions of Non-cash Assets to Owners <sup>1</sup>

<sup>1</sup> Effective for annual periods beginning on or after 1st July 2009

<sup>2</sup> Amendments that are effective for annual periods beginning on or after 1st July 2009 and 1st January 2010, as appropriate

<sup>3</sup> Effective for annual periods beginning on or after 1st January 2011

<sup>4</sup> Effective for annual periods beginning on or after 1st February 2010

<sup>5</sup> Effective for annual periods beginning on or after 1st January 2010

<sup>6</sup> Effective for annual periods beginning on or after 1st January 2013

The directors of the Company anticipate that the application of the new or revised standards, amendments or interpretations will have no material impact on the results and the financial position of the Group.

### **3. SIGNIFICANT ACCOUNTING POLICIES**

The Financial Information has been prepared on the historical cost basis, except for certain financial instruments, which are measured at fair values, as explained in the accounting policies below.

The Financial Information has been prepared in accordance with the accounting policies set out below which conform with the Hong Kong Financial Reporting Standards issued by the HKICPA.

In addition, the Financial Information includes applicable disclosures required by the Rules Governing the Listing of Securities on the Stock Exchange of Hong Kong Limited and by the Hong Kong Companies Ordinance.

#### **Basis of consolidation**

The Financial Information incorporates the financial statements of the Company and its subsidiaries. Control is achieved where the Company has the power to govern the financial and operating policies of an entity so as to obtain benefits from its activities.

The results of subsidiaries acquired or disposed of during the year/period are included in the consolidated statement of comprehensive income from the effective date of acquisition or up to the effective date of disposal, as appropriate.

Where necessary, adjustments are made to the financial statements of subsidiaries to bring their accounting policies into line with those used by other members of the Group.

All intra-group transactions, balances, income and expenses are eliminated on consolidation.

#### **Investments in subsidiaries**

Investments in subsidiaries are stated at cost less any identified impairment loss on the Company's statements of financial position.

#### **Revenue recognition**

Revenue is measured at the fair value of the consideration received or receivable and represents amounts receivable for goods sold in the normal course of business, net of discounts and related sales taxes.

Sales of goods are recognised when goods are delivered and title has passed.

Interest income from a financial asset is accrued on a time basis, by reference to the principal outstanding and at the effective interest rate applicable, which is the rate that exactly discounts the estimated future cash receipts through the expected life of the financial asset to that asset's net carrying amount.

#### **Property, plant and equipment**

Property, plant and equipment including buildings held for use in the production or supply of goods or services, or for administrative purposes (other than construction in progress) are stated at cost less subsequent accumulated depreciation and accumulated impairment losses.

Depreciation is provided to write off the cost of items of property, plant and equipment other than construction in progress over their estimated useful lives and after taking into account of their estimated residual value, using straight-line method.

Construction in progress includes property, plant and equipment in the course of construction for production or for its own use purposes. Construction in progress is carried at cost less any recognised impairment loss. Construction in progress is classified to the appropriate category of property, plant and equipment when completed and ready for intended use. Depreciation of these assets, on the same basis as other property assets, commences when the assets are ready for their intended use.

An item of property, plant and equipment is derecognised upon disposal or when no future economic benefits are expected to arise from the continued use of the asset. Any gain or loss arising on derecognition of the asset (calculated as the difference between the net disposal proceeds and the carrying amount of the item) is included in the consolidated statement of comprehensive income in the year/period in which the item is derecognised.

### **Inventories**

Inventories are stated at the lower of cost and net realisable value. Cost is calculated using the weighted average method.

### **Financial instruments**

Financial assets and financial liabilities are recognised on the consolidated and the Company's statements of financial position when a group entity becomes a party to the contractual provisions of the instrument. Financial assets and financial liabilities are initially measured at fair value. Transaction costs that are directly attributable to the acquisition or issue of financial assets and financial liabilities (other than financial assets and financial liabilities at fair value through profit or loss) are added to or deducted from the fair value of the financial assets or financial liabilities, as appropriate, on initial recognition. Transaction costs directly attributable to the acquisition of financial assets or financial liabilities at fair value through profit or loss are recognised immediately in profit or loss.

#### *Financial assets*

The Group's financial assets are classified into one of the two categories, including financial assets at fair value through profit or loss ("FVTPL") and loans and receivables. All regular way purchases or sales of financial assets are recognised and derecognised on a trade date basis. Regular way purchases or sales are purchases or sales of financial assets that require delivery of assets within the time frame established by regulation or convention in the marketplace.

#### *Effective interest method*

The effective interest method is a method of calculating the amortised cost of a financial asset and of allocating interest income over the relevant period. The effective interest rate is the rate that exactly discounts estimated future cash receipts (including all fees paid or received that form an integral part of the effective interest rate, transaction costs and other premiums or discounts) through the expected life of the financial asset, or, where appropriate, a shorter period.

Interest income is recognised on an effective interest basis for debt instruments other than those financial assets held for trading of which interest income is included in net gains or losses.

#### *Financial assets at fair value through profit or loss*

Financial assets at FVTPL represent financial assets held-for-trading.

A financial asset is classified as held-for-trading if:

- it has been acquired principally for the purpose of selling in the near future; or
- it is a part of an identified portfolio of financial instruments that the Group manages together and has a recent actual pattern of short-term profit-taking.

At end of each reporting period subsequent to initial recognition, financial assets at FVTPL are measured at fair value, with changes in fair value recognised directly in profit or loss in the period in which they arise. The net gain or loss recognised in profit or loss includes any dividend or interest earned on the financial assets.

#### *Loans and receivables*

Loans and receivables are non-derivative financial assets with fixed or determinable payments that are not quoted in an active market. At the end of each reporting period subsequent to initial recognition, loans and receivables (including trade and other receivables, amount due from a subsidiary, pledged bank balances and bank balances and cash) are carried at amortised cost using the effective interest method, less any identified impairment losses (see accounting policy on impairment loss on financial assets below).

#### *Impairment of loans and receivables*

Loans and receivables are assessed for indicators of impairment at the end of each reporting period. Loans and receivables are impaired where there is objective evidence that, as a result of one or more events that occurred after the initial recognition of the loans and receivables, the estimated future cash flows of the loans and receivables have been affected.

Objective evidence of impairment could include:

- significant financial difficulty of the issuer or counterparty; or
- default or delinquency in interest or principal payments; or
- it becoming probable that the borrower will enter bankruptcy or financial re-organisation.

For certain categories of loans and receivables, such as trade receivables and notes receivable that are assessed not to be impaired individually are subsequently assessed for impairment on a collective basis. Objective evidence of impairment for a portfolio of receivables could include the Group's past experience of collecting payments, an increase in the number of delayed payments in the portfolio past the average credit period of 30-120 days, observable changes in national or local economic conditions that correlate with default on receivables.

An impairment loss is recognised in profit or loss when there is objective evidence that the asset is impaired, and is measured as the difference between the asset's carrying amount and the present value of the estimated future cash flows discounted at the original effective interest rate.

The carrying amount of the loans and receivables is reduced by the impairment loss directly with the exception of trade receivables, where the carrying amount is reduced through the use of an allowance account. Changes in the carrying amount of the allowance account are recognised in profit or loss. When a trade receivable is considered uncollectible, it is written off against the allowance account. Subsequent recoveries of amounts previously written off are credited to profit or loss.

If, in a subsequent period, the amount of impairment loss decreases and the decrease can be related objectively to an event occurring after the impairment loss was recognised, the previously recognised impairment loss is reversed through profit or loss to the extent that the carrying amount of the asset at the date the impairment is reversed does not exceed what the amortised cost would have been had the impairment not been recognised.

***Financial liabilities and equity***

Financial liabilities and equity instruments issued by a group entity are classified according to the substance of the contractual arrangements entered into and the definitions of a financial liability and an equity instrument.

An equity instrument is any contract that evidences a residual interest in the assets of the Group after deducting all of its liabilities.

***Financial liabilities***

Financial liabilities including trade and other payables, entrusted loan and short-term bank borrowings are subsequently measured at amortised cost, using the effective interest method.

***Equity instruments***

Equity instruments including the warrants to shareholders issued by the Company are recorded at the proceeds received, net of direct issue cost.

***Effective interest method***

The effective interest method is a method of calculating the amortised cost of a financial liability and of allocating interest expense over the relevant period. The effective interest rate is the rate that exactly discounts estimated future cash payments through the expected life of the financial liability, or where appropriate, a shorter period.

Interest expense is recognised on an effective interest basis.

***Derecognition***

Financial assets are derecognised when the rights to receive cash flows from the assets expire or, the financial assets are transferred and the Group has transferred substantially all the risks and rewards of ownership of the financial assets. On derecognition of a financial asset, the difference between the asset's carrying amount and the sum of the consideration received and receivable and the cumulative gain or loss that had been recognised directly in equity is recognised in profit or loss. If the Group retains substantially all the risks and rewards of ownership of a transferred asset, the Group continues to recognise the financial asset and recognise a collateralised borrowing for proceeds received.

Financial liabilities are derecognised when the obligation specified in the relevant contract is discharged, cancelled or expires. The difference between the carrying amount of the financial liability derecognised and the consideration paid and payable is recognised in profit or loss.

**Equity-settled share-based payment transactions*****Share options granted to employees***

The fair value of services received determined by reference to the fair value of share options granted at the grant date is expensed on a straight-line basis over the vesting period, with a corresponding increase in equity (share option reserve). At the end of each reporting period, the Group revises its estimates of the number of options that are expected to ultimately vest. The impact of the revision of the estimates during the vesting period, if any, is recognised in profit or loss, with a corresponding adjustment to share option reserve.

At the time when the share options are exercised, the amount previously recognised in share option reserve will be transferred to share premium. When the share options are forfeited after the vesting date or are still not exercised at the expiry date, the amount previously recognised in share option reserve will be transferred to retained profits.

**Impairment losses on tangible assets**

At the end of each reporting period, the Group reviews the carrying amounts of its tangible assets to determine whether there is any indication that those assets have suffered an impairment loss. If the recoverable amount of an asset is estimated to be less than its carrying amount, the carrying amount of the asset is reduced to its recoverable amount. An impairment loss is recognised as an expense.

Where an impairment loss subsequently reverses, the carrying amount of the asset is increased to the revised estimate of its recoverable amount, but so that the increased carrying amount does not exceed the carrying amount that would have been determined had no impairment loss been recognised for the asset in prior years. A reversal of an impairment loss is recognised as income immediately.

**Provisions**

Provisions are recognised when the Group has a present obligation as a result of a past event, and it is probable that the Group will be required to settle that obligation and a reliable estimate can be made of the amount of the obligation. Provisions are measured at the directors' best estimate of the expenditure required to settle the obligation at the end of each reporting period, and are discounted to present value where the effect is material.

**Taxation**

Income tax expense represents the sum of the tax currently payable and deferred tax.

The tax currently payable is based on taxable profit for the year/period. Taxable profit differs from profit as reported in the consolidated statement of comprehensive income because it excludes items of income or expense that are taxable or deductible in other years and it further excludes items that are never taxable or deductible. The Group's liability for current tax is calculated using tax rates that have been enacted or substantively enacted by the end of each reporting period.

Deferred tax is recognised on differences between the carrying amount of assets and liabilities in the Financial Information and the corresponding tax bases used in the computation of taxable profit, and is accounted for using the balance sheet liability method. Deferred tax liabilities are generally recognised for all taxable temporary differences and deferred tax assets are recognised to the extent that it is probable that taxable profits will be available against which deductible temporary differences can be utilised. Such assets and liabilities are not recognised if the temporary difference arises from goodwill or from the initial recognition (other than in a business combination) of other assets and liabilities in a transaction that affects neither the taxable profit nor the accounting profit.

Deferred tax liabilities are recognised for taxable temporary differences arising on investments in subsidiaries except where the Group is able to control the reversal of the temporary difference and it is probable that the temporary difference will not reverse in the foreseeable future.

The carrying amount of deferred tax assets is reviewed at the end of each reporting period and reduced to the extent that it is no longer probable that sufficient taxable profits will be available to allow all or part of the asset to be recovered.

Deferred tax is calculated at the tax rates that are expected to apply in the period when the liability is settled or the asset is realised, based on tax rates that have been enacted or substantively enacted by the end of each reporting period. Deferred tax is charged or credited to the profit or loss, except when it relates to items charged or credited directly to equity, in which case the deferred tax is also dealt with in equity.

**Research and development expenditure**

Expenditure on research activities is recognised as an expense in the period in which it is incurred.

An internally-generated intangible asset arising from development expenditure is recognised only if it is anticipated that the development costs incurred on a clearly-defined project will be recovered through future commercial activity. The resultant asset is amortised on a straight-line basis over its useful life, and carried at cost less subsequent accumulated amortisation and any accumulated impairment losses.

The amount initially recognised for internally-generated intangible asset is the sum of the expenditure incurred from the date when the intangible asset first meets the recognition criteria. Where no internally-generated intangible asset can be recognised, development expenditure is charged to profit or loss in the period in which it is incurred.

Subsequent to initial recognition, internally-generated intangible asset is reported at cost less accumulated amortisation and accumulated impairment losses, on the same basis as intangible assets acquired separately.

**Foreign currencies**

In preparing the financial statements of each individual group entity, transactions in currencies other than the functional currency of that entity (foreign currencies) are recorded in the respective functional currency (i.e. the currency of the primary economic environment in which the entity operates) at the rates of exchanges prevailing on the dates of the transactions. At the end of each reporting period, monetary items denominated in foreign currencies are retranslated at the rates prevailing at the end of each reporting period. Non-monetary items that are measured in terms of historical cost in a foreign currency are not retranslated.

Exchange differences arising on the settlement of monetary items, and on the retranslation of monetary items, are recognised in profit or loss in the period in which they arise.

**Borrowing costs**

Borrowing costs directly attributable to the acquisition, construction or production of qualifying assets, are capitalised as part of the cost of those assets. Capitalisation of such borrowing costs ceases when the assets are substantially ready for their intended use or sale.

All other borrowing costs are recognised in profit or loss in the period in which they are incurred.

**Government grants**

Government grants are recognised as income over the periods necessary to match them with the related costs. Grants related to depreciable assets are presented as deferred income and are released to income over the useful lives of the assets. Grants related to expense items are recognised in the same period as those expenses are charged in the consolidated statement of comprehensive income and are reported separately as 'other income'.

**Retirement benefits costs**

Payments to state-managed retirement benefit schemes are charged as an expense when employees have rendered service entitling them to the contributions.

**Leasing**

Leases are classified as finance leases whenever the terms of the lease transfer substantially all the risks and rewards of ownership to the lessee. All other leases are classified as operating leases.

*The Group as lessee*

Rentals payable under operating leases are charged to profit or loss on a straight-line basis over the term of the relevant lease. Benefits received and receivable as an incentive to enter into an operating lease are recognised as a reduction of rental expense over the lease term on a straight-line basis.

**4. KEY SOURCES OF ESTIMATION UNCERTAINTY**

In the application of the Group's accounting policies, which are described in note 3, the directors of the Company are required to make estimates and assumptions about the carrying amounts of assets and liabilities that are not readily apparent from other sources. The estimates and associated assumptions are based on historical experience and other factors that are considered to be relevant. Actual results may differ from these estimates.

The estimates and underlying assumptions are reviewed on an ongoing basis. Revisions to accounting estimates are recognised in the period in which the estimate is revised if the revision affects only that period, or in the period of the revision and future periods if the revision affects both current and future periods.

**Income taxes**

No deferred tax asset has been recognised on the tax losses of RMB6,483,000 as at 31st August 2009 (31st December 2008: RMB4,131,000, 31st December 2007: nil, 31st December 2006: nil) due to the unpredictability of future profit streams. The realisability of the deferred tax asset mainly depends on whether sufficient future profits or taxable temporary differences will be available in the future. In cases where it is probable that there is sufficient future profits or taxable temporary differences, deferred tax asset would be recognised.

**5. CAPITAL RISK MANAGEMENT**

The Group manages its capital to ensure that entities in the Group will be able to continue as a going concern while maximising the return to owners through the optimisation of the debt and equity balance.

The capital structure of the Group consists of debts, which include an entrusted loan and short-term bank borrowings disclosed in notes 21 and 23 respectively, and equity attributable to owners of the Company, comprising issued capital, share premium and other reserves.

The Group reviews the capital structure on an ongoing basis. As a part of this review, the Group considers the cost of capital and the risks associated with each class of capital. The Group balances its overall capital structure through issuance of new share issues and new debt. The Group's overall strategy remains unchanged throughout the Relevant Periods.

## 6. FINANCIAL RISK MANAGEMENT OBJECTIVES AND POLICIES

Details of the significant accounting policies adopted, including the criteria for recognition, the basis of measurement and the bases on which income and expenses are recognised, in respect of each class of financial assets and financial liabilities are disclosed in note 3. Details of these financial instruments are disclosed below:

### Categories of financial instruments

	At 31st December			At 31st
	2006	2007	2008	August
	RMB'000	RMB'000	RMB'000	2009
The Group				RMB'000
<b>Financial assets</b>				
Loans and receivables (including bank balances and cash)	<u>245,493</u>	<u>406,611</u>	<u>425,386</u>	<u>615,268</u>
<b>Financial liabilities</b>				
Amortised cost	<u>155,263</u>	<u>354,265</u>	<u>450,348</u>	<u>642,745</u>

	At 31st December			At 31st
	2006	2007	2008	August
	RMB'000	RMB'000	RMB'000	2009
The Company				RMB'000
<b>Financial assets</b>				
Loans and receivables (including bank balances and cash)	<u>16,593</u>	<u>13,799</u>	<u>10,575</u>	<u>9,618</u>
<b>Financial liabilities</b>				
Amortised cost	<u>2</u>	<u>4,447</u>	<u>4,582</u>	<u>4,622</u>

### Financial risk management objectives and policies

The Group's and the Company's major financial instruments include trade and other receivables, held-for-trading financial assets, amount due from a subsidiary, pledged bank balances, bank balances and cash, trade and other payables, dividend payable and short-term bank borrowings. Details of these financial instruments are disclosed in respective notes. The risks associated with these financial instruments and the policies on how to mitigate these risks are set out below. The management manages and monitors these exposures to ensure appropriate measures are implemented on a timely and effective manner.

### Credit risk

The Group's and the Company's principal financial assets are trade and other receivables, amount due from a subsidiary, bank balances and cash and pledged bank balances, which represent the Group's maximum exposure to credit risk in relation to financial assets at the end of each reporting period. The Group's credit risk is primarily attributable to its trade receivables and notes receivable. The credit risk on trade receivables and notes receivable are concentrated on top five customers of the Group. In order to minimise the credit risk, the management of the Group has delegated a team responsible for determination of credit limits, credit approvals and other monitoring procedures to

ensure that follow-up action is taken to recover overdue debts. The Group reviews the recoverable amount of each individual trade receivable and notes receivable at the end of each reporting period to ensure that adequate impairment losses are made for irrecoverable amounts. In this regard, the directors of the Company consider the Group's credit risk is significantly reduced.

The credit risk of the Group and the Company on liquid funds is limited because the majority of the counterparties are international banks and state-owned banks with good reputation.

The Group sells most of the products to a small number of customers in the PRC. If the Group is unable to broaden the customer base and expand relationships with major wireless network solution providers and major network operators, the business may continue to be impacted by unanticipated demand fluctuations which can have a negative impact on the revenues and business, and an adverse effect on the results of operations and financial condition.

The Group has a significant concentration of customers. For the eight months ended 31st August 2009 and 31st August and 2008 (unaudited), aggregate sales to the top five customers of the Group accounted for approximately 91.4% and 92.0% (year ended 31st December 2008: 85.8%, 31st December 2007: 90.2%, 31st December 2006: 87.2%) of the total sales. Amount due from them as at 31st August 2009 amounted to approximately RMB284,385,000 (31st December 2008: RMB135,177,000, 31st December 2007: RMB172,159,000, 31st December 2006: RMB110,584,000), representing 90.5% (31st December 2008: 65.3%, 31st December 2007: 83.3%, 31st December 2006: 76.2%) of trade receivables (before making allowance for doubtful debt) as at 31st August 2009. These major customers are PRC network operators and domestic and overseas wireless network solution providers with good reputation.

#### Currency risk

The Group has foreign currency sales and purchases and certain trade receivables, bank balances, trade payables and borrowings of the Group are denominated in United States dollar ("USD"), Euro ("EUR") and Hong Kong dollar ("HKD"), currencies other than the functional currency of the respective group entities, which expose the Group to foreign currency risk. The Company's bank balances are denominated in USD and HKD. The Group currently does not have a foreign currency hedging policy. However, the management monitors foreign exchange exposure and will consider hedging significant foreign currency exposure when the need arises.

The carrying amount of the foreign currency denominated monetary assets and monetary liabilities at the end of each reporting period are as follows:

	2006		At 31st December 2007		2008		31st August 2009	
	Assets	Liabilities	Assets	Liabilities	Assets	Liabilities	Assets	Liabilities
	RMB'000	RMB'000	RMB'000	RMB'000	RMB'000	RMB'000	RMB'000	RMB'000
The Group								
USD	<u>33,045</u>	<u>—</u>	<u>73,737</u>	<u>6,343</u>	<u>40,948</u>	<u>6,343</u>	<u>25,528</u>	<u>19,478</u>
EUR	<u>—</u>	<u>—</u>	<u>31,371</u>	<u>—</u>	<u>13,118</u>	<u>—</u>	<u>9,654</u>	<u>—</u>
HKD	<u>68</u>	<u>—</u>	<u>15</u>	<u>290</u>	<u>5</u>	<u>290</u>	<u>217</u>	<u>290</u>
The Company								
USD	<u>16,543</u>	<u>—</u>	<u>11,960</u>	<u>6,343</u>	<u>9,674</u>	<u>6,343</u>	<u>8,504</u>	<u>6,343</u>
HKD	<u>50</u>	<u>—</u>	<u>—</u>	<u>290</u>	<u>1</u>	<u>290</u>	<u>214</u>	<u>290</u>

The following table details the sensitivity to a 5% change in the RMB against USD, EUR and HKD. The 5% is the rate used when reporting currency risk internally to key management personnel and represents management's assessment of the reasonably possible change in the foreign exchange rates. The sensitivity analyses of the Group's exposure to foreign currency risk at the end of each reporting period have been determined based on the adjustment of translation of the monetary assets and liabilities at the end of each reporting period for a 5% change in foreign currency rates. A positive or negative number indicates an increase or a decrease in the post-tax profit/a decrease or an increase in post-tax loss where RMB strengthens against USD, EUR and HKD. For a 5% weakening of RMB against USD, EUR and HKD, there would be an equal and opposite impact of the post-tax profit or loss.

	Year ended 31st December			Eight months ended 31st August
	2006	2007	2008	2009
	RMB'000	RMB'000	RMB'000	RMB'000
The Group				
Increase (decrease) in post-tax profit (i)				
If RMB strengthens against USD	(1,404)	(2,862)	(1,443)	(259)
If RMB strengthens against EUR	—	(1,333)	(558)	(410)
If RMB strengthens against HKD	<u>(3)</u>	<u>11</u>	<u>12</u>	<u>3</u>
The Company				
Increase (decrease) in post-tax profit or (increase) decrease in post-tax loss				
If RMB strengthens against USD	(703)	(239)	(114)	(89)
If RMB strengthens against HKD	<u>(2)</u>	<u>12</u>	<u>12</u>	<u>3</u>

(i) This is mainly attributable to the outstanding foreign currency receivables and bank balances at year/period end as a result of the foreign currency sales in the Group.

In management's opinion, the sensitivity analysis is unrepresentative of the inherent foreign exchange risk as the exposure at the end of each reporting period does not reflect the exposure during the Relevant Periods.

### Interest rate risk

The Group is exposed to fair value interest rate risk which arises from pledged bank balances and fixed rate bank borrowings (note 23). Interest bearing pledged bank balance and bank balances are mainly short-term nature. Therefore, any variations in interest rate will not have a significant impact on the results of the Group.

The Group is also exposed to cash flow interest rate risk in relation to bank balances and variable-rate bank borrowings (note 23). The Group's cash flow interest rate risk is mainly concentrated on the fluctuation of The People's Bank of China Benchmark Interest Rates ("PBOC Rate") arising from the Group's RMB denominated borrowings.

The Group currently does not have an interest rate hedging policy. However, the management monitors interest rate exposure and will consider hedging significant interest rate exposure should the need arise.

The Company has no significant interest rate risk.

If interest rate on bank balances had been 30 basis points higher and interest rate on short-term floating rate bank borrowings had been 50 basis points higher and all other variables were held constant, the potential effect on the post-tax profit for the year/period is as follows (if interest rate on bank balances had been 30 basis points lower and interest rate on short-term floating rate bank borrowings had been 50 basis points lower and all other variables were held constant, there would be an equal and opposite impact on post-tax profit):

	Year ended 31st December			Eight months ended 31st August
	2006	2007	2008	2009
	RMB'000	RMB'000	RMB'000	RMB'000
The Group				
<b>If the interest rate goes up</b>				
Increase (decrease) in post-tax profit	<u>120</u>	<u>157</u>	<u>(19)</u>	<u>(92)</u>

### Liquidity risk

In the management of the liquidity risk, the Group monitors and maintains a level of cash and cash equivalents deemed adequate by the management to finance the Group's operations and mitigate the effects of fluctuations in cash flows. The management monitors the utilisation of bank borrowings and ensures compliance with loan covenants.

Banking facilities available to the Group as at 31st December 2006, 31st December 2007, 31st December 2008 and 31st August 2009 are approximately RMB37.9 million, RMB169.2 million, RMB371.9 million and RMB 473.9 million respectively.

The Group relies on bank balances and cash, and bank borrowings as a source of liquidity. Undrawn borrowing facilities of the Group as at 31st December 2006, 31st December 2007, 31st December 2008 and 31st August 2009 are approximately RMB16,917,000, RMB71,847,000, RMB151,250,000 and RMB162,843,000, respectively.

The following table details the remaining contractual maturity for its financial liabilities. The table includes both interest and principal cash flows.

### Liquidity risk table

#### The Group

	Weighted average effective interest rate %	Payable on demand RMB'000	0 to 30 days RMB'000	31 to 60 days RMB'000	61 to 90 days RMB'000	91 to 180 days RMB'000	180 to 365 days RMB'000	Total undiscounted cash flows RMB'000	Carrying amount at 31st August 2009 RMB'000
<b>31st August 2009</b>									
Trade and other payables	—	195,142	103,103	112,412	47,586	22,212	3,788	484,243	484,243
Dividend payable	—	758	—	—	—	—	—	758	758
Short-term bank borrowings	4.03	—	35,502	388	45,975	59,451	18,311	159,627	157,744
		<u>195,900</u>	<u>138,605</u>	<u>112,800</u>	<u>93,561</u>	<u>81,663</u>	<u>22,099</u>	<u>644,628</u>	<u>642,745</u>
	Weighted average effective interest rate %	Payable on demand RMB'000	0 to 30 days RMB'000	31 to 60 days RMB'000	61 to 90 days RMB'000	91 to 180 days RMB'000	180 to 365 days RMB'000	Total undiscounted cash flows RMB'000	Carrying amount at 31st December 2008 RMB'000
<b>31st December 2008</b>									
Trade and other payables	—	48,921	208,374	37,283	42,956	31,838	7,093	376,465	376,465
Dividend payable	—	429	—	—	—	—	—	429	429
Short-term bank borrowings	5.57	—	28,795	20,323	25,243	186	—	74,547	73,454
		<u>49,350</u>	<u>237,169</u>	<u>57,606</u>	<u>68,199</u>	<u>32,024</u>	<u>7,093</u>	<u>451,441</u>	<u>450,348</u>
	Weighted average effective interest rate %	Payable on demand RMB'000	0 to 30 days RMB'000	31 to 60 days RMB'000	61 to 90 days RMB'000	91 to 180 days RMB'000	180 to 365 days RMB'000	Total undiscounted cash flows RMB'000	Carrying amount at 31st December 2007 RMB'000
<b>31st December 2007</b>									
Trade and other payables	—	96,196	78,205	39,878	34,002	20,847	10,637	279,765	279,765
Short-term bank borrowings	5.71	—	355	30,355	24,796	15,344	—	70,850	69,500
Entrusted loan	—	—	—	—	5,000	—	—	5,000	5,000
		<u>96,196</u>	<u>78,560</u>	<u>70,233</u>	<u>63,798</u>	<u>36,191</u>	<u>10,637</u>	<u>355,615</u>	<u>354,265</u>

**APPENDIX I**

**ACCOUNTANTS' REPORT**

	Weighted average interest rate %	Payable on demand RMB'000	0 to 30 days RMB'000	31 to 60 days RMB'000	61 to 90 days RMB'000	91 to 180 days RMB'000	180 to 365 days RMB'000	Total undiscounted cash flows RMB'000	Carrying amount at 31st December 2006 RMB'000
<b>31st December 2006</b>									
Trade and other payables	—	40,021	37,284	24,970	33,429	—	11,650	147,354	147,354
Short-term bank borrowings	3.30	—	7,931	—	—	—	—	7,931	7,909
		<u>40,021</u>	<u>45,215</u>	<u>24,970</u>	<u>33,429</u>	<u>—</u>	<u>11,650</u>	<u>155,285</u>	<u>155,263</u>

*The Company*

	Weighted average interest rate %	Payable on demand RMB'000	0 to 30 days RMB'000	31 to 60 days RMB'000	61 to 90 days RMB'000	91 to 180 days RMB'000	180 to 365 days RMB'000	Total undiscounted cash flows RMB'000	Carrying amount at 31st August 2009 RMB'000
<b>31st August 2009</b>									
Trade and other payables	—	—	1,158	—	—	—	2,706	3,864	3,864
Dividend payable	—	758	—	—	—	—	—	758	758
		<u>758</u>	<u>1,158</u>	<u>—</u>	<u>—</u>	<u>—</u>	<u>2,706</u>	<u>4,622</u>	<u>4,622</u>

	Weighted average interest rate %	Payable on demand RMB'000	0 to 30 days RMB'000	31 to 60 days RMB'000	61 to 90 days RMB'000	91 to 180 days RMB'000	180 to 365 days RMB'000	Total undiscounted cash flows RMB'000	Carrying amount at 31st December 2008 RMB'000
<b>31st December 2008</b>									
Trade and other payables	—	—	—	290	—	—	3,863	4,153	4,153
Dividend payable	—	429	—	—	—	—	—	429	429
		<u>429</u>	<u>—</u>	<u>290</u>	<u>—</u>	<u>—</u>	<u>3,863</u>	<u>4,582</u>	<u>4,582</u>

	Weighted average interest rate %	Payable on demand RMB'000	0 to 30 days RMB'000	31 to 60 days RMB'000	61 to 90 days RMB'000	91 to 180 days RMB'000	180 to 365 days RMB'000	Total undiscounted cash flows RMB'000	Carrying amount at 31st December 2007 RMB'000
<b>31st December 2007</b>									
Trade and other payables	—	—	295	—	—	—	4,152	4,447	4,447

	Weighted average interest rate %	Payable on demand RMB'000	0 to 30 days RMB'000	31 to 60 days RMB'000	61 to 90 days RMB'000	91 to 180 days RMB'000	180 to 365 days RMB'000	Total undiscounted cash flows RMB'000	Carrying amount at 31st December 2006 RMB'000
<b>31st December 2006</b>									
Trade and other payables	—	—	—	—	—	—	2	2	2

**Fair value**

The fair value of financial assets and financial liabilities are determined in accordance with generally accepted pricing models based on discounted cash flow analysis or using prices from observable current market transactions.

The directors of the Company consider that carrying amounts of financial assets and financial liabilities recorded at amortised cost in the Financial Information approximate their fair values.

**7. TURNOVER AND SEGMENT INFORMATION**

Segment information has been identified on the basis of internal management reports which are prepared in accordance with accounting policies conform with HKFRS, that are regularly reviewed by the chief operating decision maker (the “CODM”), the chief executive officer of the Company, in order to allocate resources to the reportable segments and to assess their performance. The Group does not allocate other income, distribution and selling expenses, administrative expenses, finance costs and income tax expense to individual reporting segments when making decisions about resources to be allocated to the segments and assessing their performance.

The Group’s reportable segments under HKFRS 8 are as follows:

Antenna system — manufacture and sale of antenna system and related products

Base station RF subsystem — manufacture and sale of base station RF subsystem and related products

Coverage extension solution — manufacture and sale of a wide array of coverage products

## Information of segment revenues and segment results

The information of segment revenues and segment results are as follows:

	Year ended 31st December			Eight months ended	
	2006	2007	2008	31st August 2008	2009
	RMB'000	RMB'000	RMB'000	RMB'000	RMB'000
				<i>(unaudited)</i>	
<b>Segment revenues</b>					
Antenna system	186,392	268,751	260,543	129,641	276,282
Base station RF subsystem	165,433	340,940	388,675	285,025	274,501
Coverage extension solution	9,131	17,115	21,964	11,772	81,584
	<u>360,956</u>	<u>626,806</u>	<u>671,182</u>	<u>426,438</u>	<u>632,367</u>
<b>Segment results</b>					
Antenna system	38,976	65,325	63,533	31,348	74,696
Base station RF subsystem	28,925	63,107	84,327	61,388	59,044
Coverage extension solution	1,996	755	888	(545)	25,449
	<u>69,897</u>	<u>129,187</u>	<u>148,748</u>	<u>92,191</u>	<u>159,189</u>
Reconciliation of segment results to profit before taxation:					
Other income	3,741	2,943	7,103	3,647	3,610
Other expenses	(39,985)	(69,694)	(82,571)	(49,372)	(63,236)
Finance costs	(153)	(2,899)	(3,803)	(2,932)	(2,664)
Profit before taxation	<u>33,500</u>	<u>59,537</u>	<u>69,477</u>	<u>43,534</u>	<u>96,899</u>
Other information:					
Depreciation					
Antenna system	1,736	2,963	3,427	1,828	2,870
Base station RF subsystem	1,541	3,758	5,113	4,019	2,851
Coverage extension solution	85	189	289	166	847
Segment total	3,362	6,910	8,829	6,013	6,568
Unallocated amount	2,194	3,010	4,642	2,551	3,342
Group total	<u>5,556</u>	<u>9,920</u>	<u>13,471</u>	<u>8,564</u>	<u>9,910</u>
Research and development costs					
Antenna system	6,251	9,704	13,026	8,056	8,799
Base station RF subsystem	7,464	11,999	15,340	9,484	9,289
Coverage extension solution	1,456	3,242	6,184	4,114	3,217
Group total	<u>15,171</u>	<u>24,945</u>	<u>34,550</u>	<u>21,654</u>	<u>21,305</u>

Revenues reported above represent revenues generated from external customers. There are no inter-segment sales during the Relevant Periods.

The accounting policies of the reportable segments are the same as the Group's accounting policies described in note 3.

### Entity-wide disclosures:

#### Information about products

Revenues from each group of similar products within the reportable segments are as follows:

	Year ended 31st December			Eight months ended	
	2006	2007	2008	31st August 2008	2009
	RMB'000	RMB'000	RMB'000	RMB'000	RMB'000
				<i>(unaudited)</i>	
<b>Antenna system</b>					
CDMA/GSM fixed-downtilt antennas	111,001	116,681	80,663	28,761	81,795
CDMA/GSM remote electric-downtilt antennas	845	14,134	18,728	8,847	35,976
PHS antennas	25,482	8,908	1,957	1,361	90
Yagi antennas	32,172	6,708	1,095	253	276
W-CDMA antennas	1,238	1,287	72,059	44,350	74,404
TD-SCDMA antennas	38	20,823	5,711	4,564	23,488
Microwave antennas	10,203	82,943	62,276	34,167	30,114
Other antennas	5,413	17,267	18,054	7,338	30,139
	<u>186,392</u>	<u>268,751</u>	<u>260,543</u>	<u>129,641</u>	<u>276,282</u>
<b>Base Station RF Subsystem</b>					
CDMA2000 RF devices	16,382	59,049	50,757	28,784	65,151
CDMA RF devices	37,823	34,510	33,323	28,431	17,724
GSM RF devices	105,506	112,910	198,490	139,102	134,540
CDMA/GSM RF devices	230	119,358	95,901	81,449	30,494
TD-SCDMA RF devices	496	9,146	2,016	1,487	1,128
W-CDMA RF devices	4,684	5,228	7,548	5,512	23,014
Other devices	312	739	640	260	2,450
	<u>165,433</u>	<u>340,940</u>	<u>388,675</u>	<u>285,025</u>	<u>274,501</u>
<b>Coverage Extension Solution</b>					
In-door antennas	6,426	4,368	4,085	3,096	721
Aesthetic antennnas	—	3,456	9,372	3,608	36,674
Other antennas	2,705	1,124	4,100	3,142	9,160
Electric cables	—	8,167	4,407	1,926	35,029
	<u>9,131</u>	<u>17,115</u>	<u>21,964</u>	<u>11,772</u>	<u>81,584</u>
	<u>360,956</u>	<u>626,806</u>	<u>671,182</u>	<u>426,438</u>	<u>632,367</u>

No operating results nor discrete financial information in respect of each group of similar products is presented to CODM.

**Information about major customers**

Revenues from customers of the corresponding periods contributing over 10% of the total sales of the Group are as follows:

	Year ended 31st December			Eight months ended	
	2006	2007	2008	31st August 2008	2009
	RMB'000	RMB'000	RMB'000	RMB'000	RMB'000
				<i>(unaudited)</i>	
Customer A <sup>1</sup>	166,757	248,520	237,314	120,883	231,864
Customer B <sup>2</sup>	N/A <sup>4</sup>	N/A <sup>4</sup>	N/A <sup>4</sup>	N/A <sup>4</sup>	148,025
Customer C <sup>3</sup>	51,849	150,984	160,833	135,278	90,402
Customer D <sup>2</sup>	N/A <sup>4</sup>	107,439	77,540	59,666	N/A <sup>4</sup>
Customer E <sup>2</sup>	39,961	N/A <sup>4</sup>	N/A <sup>4</sup>	N/A <sup>4</sup>	N/A <sup>4</sup>
Customer F <sup>3</sup>	N/A <sup>4</sup>	N/A <sup>4</sup>	N/A <sup>4</sup>	57,024	N/A <sup>4</sup>

<sup>1</sup> revenue from antenna system and base station RF subsystem

<sup>2</sup> revenue from antenna system

<sup>3</sup> revenue from base station RF subsystem

<sup>4</sup> The corresponding revenue does not contribute over 10% of the total sales of the Group in the respective year/period.

**Geographical information**

The reporting segments of the Group are mainly operated in the PRC and overseas (mainly Finland and India). An analysis of the Group's geographical information on revenue attributed to the region on the basis of the customer's location for the Relevant Periods is set out in the following table:

	Year ended 31st December			Eight months ended	
	2006	2007	2008	31st August 2008	2009
	RMB'000	RMB'000	RMB'000	RMB'000	RMB'000
				<i>(unaudited)</i>	
PRC	319,252	393,271	466,320	261,178	581,072
Overseas					
India	13,905	111,166	79,342	60,033	4,594
Finland	25,492	112,494	102,687	87,522	41,156
Others	2,307	9,875	22,833	17,705	5,545
Subtotal	41,704	233,535	204,862	165,260	51,295
	<u>360,956</u>	<u>626,806</u>	<u>671,182</u>	<u>426,438</u>	<u>632,367</u>

All non-current assets of the Group are located in the PRC.

## 8. OTHER INCOME

	Year ended 31st December			Eight months ended	
	2006	2007	2008	31st August	
	RMB'000	RMB'000	RMB'000	2008	2009
				<i>(unaudited)</i>	
Government grants					
- related to expense items	1,027	286	3,080	1,154	1,542
- related to assets (note 24)	18	112	563	373	920
Compensation income	71	525	1,158	329	877
Tax refund for re-investment in MOBI Shenzhen and MOBI Jian	—	97	1,058	1,058	—
Interest income	810	751	880	457	190
Sales of materials and scraps	1,731	1,041	131	131	—
Gain on disposals of held-for-trading financial assets	—	—	120	106	—
Gain on disposals of property, plant and equipment	—	—	6	8	—
Others	84	131	107	31	81
	<u>3,741</u>	<u>2,943</u>	<u>7,103</u>	<u>3,647</u>	<u>3,610</u>

## 9. FINANCE COSTS

	Year ended 31st December			Eight months ended	
	2006	2007	2008	31st August	
	RMB'000	RMB'000	RMB'000	2008	2009
				<i>(unaudited)</i>	
Interest on bank borrowings					
- wholly repayable within five years	153	2,899	3,803	2,932	2,664
	<u>153</u>	<u>2,899</u>	<u>3,803</u>	<u>2,932</u>	<u>2,664</u>

## 10. INCOME TAX EXPENSE

	Year ended 31st December			Eight months ended	
	2006	2007	2008	31st August 2008	2009
	RMB'000	RMB'000	RMB'000	RMB'000	RMB'000
PRC income tax	2,019	4,291	12,025	8,272	14,078
Deferred tax (note 18)					
- current year/period	—	(1,527)	(4,491)	(2,104)	(1,384)
- attributable to a change on tax rate	—	—	18	18	—
	<u>2,019</u>	<u>2,764</u>	<u>7,552</u>	<u>6,186</u>	<u>12,694</u>

The Company was incorporated in the Cayman Islands and is exempted from income tax because no assessable profit is generated and it is not subject to other jurisdictions.

MOBI Shenzhen was established in Shenzhen, PRC, with applicable tax rate of 15%. MOBI Shenzhen is a High Technology company defined by Shenzhen Science and Technology Bureau and therefore is entitled to 50% relief from PRC enterprise income tax of 15% for three years starting from 2006. Accordingly, the applicable tax rate for MOBI Shenzhen is 7.5% for the year ended 31st December 2006 and 31st December 2007. On 16th March 2007, the PRC promulgated the Law of the People's Republic of China on Enterprise Income Tax by Order No. 63 of the President of the People's Republic of China (the "New PRC Enterprise Income Tax Law"), which become effective on 1st January 2008. The New PRC Enterprise Income Tax Law revokes the former preferential income tax treatment granted to MOBI Shenzhen. In 2008, MOBI Shenzhen is a High and New Technology Enterprise company defined by Shenzhen Finance Bureau, Administrator of Local Taxation of Shenzhen Municipality and Shenzhen Municipal office of the State Administration of Taxation and therefore is entitled to 15% preferential tax rate from PRC enterprise income tax for three years starting from 2008. Accordingly, the tax rate for MOBI Shenzhen is 15% for the year ended 31st December 2008 and for the eight months ended 31st August 2009. The deferred tax balance has been adjusted to reflect the tax rates that are expected to apply to the respective years when the asset is realised or the liability is settled.

The applicable tax rate of MOBI Jian is 33% before 2007, and according to the New PRC Enterprise Income Tax Law, the applicable tax rate is decreased to 25% from 1st January 2008. In accordance with the tax legislations applicable to MOBI Jian, it is entitled to exemption from PRC enterprise income tax for the two years commencing from its first profit making year of operations, after offsetting all unexpired tax losses carried forward from previous years, and thereafter, entitled to a 50% relief from PRC enterprise income tax of 25% for the next three years. Accordingly, the tax rate for MOBI Jian is nil for the period from 23th May 2006 (date of establishment) to 31st December 2006 and the year ended 31st December 2007 and 12.5% for the year ended 31st December 2008 and for the eight months ended 31st August 2009.

The applicable tax rate of MOBI Xian is 25% for the period from 28th April 2008 (date of establishment) to 31st December 2008 and for the eight months ended 31st August 2009.

Tax charge for the year/period is reconciled to profit before taxation as follows:

	Year ended 31st December			Eight months ended	
	2006	2007	2008	31st August 2008	2009
	RMB'000	RMB'000	RMB'000	RMB'000	RMB'000
Profit before taxation	<u>33,500</u>	<u>59,537</u>	<u>69,477</u>	<u>43,534</u>	<u>96,899</u>
Tax at PRC Enterprise Income					
Tax at 15% (a)	5,025	8,931	10,421	6,530	14,535
Tax effect of expenses not deductible for tax purpose (b)	1,693	835	435	2,119	329
Tax effect of income not taxable for tax purpose	(3)	(17)	(84)	(56)	(138)
Tax benefit (c)	(1,138)	(1,871)	(2,440)	(1,624)	(1,425)
Effect of tax exemption granted to MOBI Jian	(3,385)	(2,231)	—	—	—
Effect of 50% tax relief granted to MOBI Shenzhen and MOBI Jian	(2,019)	(4,100)	(3,558)	(1,359)	(3,520)
Tax effect of tax losses not recognised of MOBI Xian	—	—	620	57	353
Effect of different tax rates of group entities	1,846	1,217	2,849	1,088	2,815
Effect of excess of applicable tax rate for deferred tax over current tax on deductible temporary difference	—	—	(709)	(587)	(255)
Decrease in opening deferred tax assets resulting from a decrease in applicable tax rate	—	—	18	18	—
Tax charge for the year	<u>2,019</u>	<u>2,764</u>	<u>7,552</u>	<u>6,186</u>	<u>12,694</u>

Notes:

- (a) Applicable income tax rate of 15% represents the relevant income tax rate of MOBI Shenzhen, the major subsidiary of the Group.
- (b) The amounts mainly represent the tax effect of certain expenses such as advertisements and entertainment which exceed the deductible limit specified by the local tax bureau.
- (c) Tax benefit represents an incentive scheme that, in addition to the research and development cost which is deductible for tax purpose, further 50% of the research and development cost is deductible.

**11. PROFIT AND THE TOTAL COMPREHENSIVE INCOME FOR THE YEAR/PERIOD AND ATTRIBUTABLE TO OWNERS OF THE COMPANY**

	Year ended 31st December			Eight months ended	
	2006	2007	2008	31st August 2008	2009
	RMB'000	RMB'000	RMB'000	RMB'000	RMB'000
				<i>(unaudited)</i>	
Profit for the year/period has been arrived at after charging (crediting):					
Directors' remuneration (note 12)	1,436	1,093	1,495	857	917
Retirement benefits scheme contributions	1,086	1,694	2,523	2,013	3,350
Other staff costs (a)	35,317	59,211	87,337	57,474	65,625
Equity-settled share-based payment expenses	1,126	889	802	556	491
	<u>38,965</u>	<u>62,887</u>	<u>92,157</u>	<u>60,900</u>	<u>70,383</u>
Auditors' remuneration	380	458	372	—	—
Operating lease rentals in respect of					
- prepaid lease payments	79	91	372	61	285
- rented premises	3,920	4,916	4,320	2,136	3,057
Depreciation	5,556	9,920	13,471	8,564	9,910
Cost of inventories recognised as expenses	275,888	472,674	487,884	312,593	451,873
(Reversals of) allowance for doubtful debts (included in administrative expenses) (b)	(192)	782	452	452	—
Write-down of inventories (included in administrative expenses)	1,130	1	361	200	721
Loss on disposals of property, plant and equipment	3	1	—	—	86
Net exchange loss	<u>1,164</u>	<u>4,613</u>	<u>6,596</u>	<u>6,376</u>	<u>178</u>

*Notes:*

- (a) Included in other staff costs is RMB655,000, RMB1,449,000, RMB2,205,000, RMB1,502,000 (unaudited) and RMB1,328,000 for the three years ended 31st December 2008 and the eight months ended 31st August 2008 and 31st August 2009, respectively, represents the rental expense for the staff quarter.
- (b) Reversal of allowance for bad and doubtful debts was made when the recoverable amount of those debts on which allowance had previously been made is estimated to be greater than its carrying amount.

## 12. DIRECTORS' AND EMPLOYEES' EMOLUMENTS

## Directors' emoluments

The aggregate amounts of emoluments paid and payable to the executive directors and non-executive directors of the Company by the Group during the Relevant Periods are as follows:

For the year ended 31st December 2006					
	Fees	Retirement benefits scheme contributions	Other emoluments (mainly basic salaries, bonus and allowances)	Equity- settled share-based payment expenses	Total
	<i>RMB'000</i>	<i>RMB'000</i>	<i>RMB'000</i>	<i>RMB'000</i>	<i>RMB'000</i>
<b>Executive directors</b>					
Hu Xiang	—	—	542	195	737
Wang Guoying	—	6	483	83	572
<b>Non-executive directors</b>					
Qu Deqian	—	—	—	29	29
Xing Qibin	—	—	—	29	29
Yan Andrew Y.	—	—	—	32	32
Yang Dong	—	—	—	32	32
Huang Jinsheng	—	—	—	5	5
	<u>—</u>	<u>6</u>	<u>1,025</u>	<u>405</u>	<u>1,436</u>

For the year ended 31st December 2007					
	Fees	Retirement benefits scheme contributions	Other emoluments (mainly basic salaries, bonus and allowances)	Equity- settled share-based payment expenses	Total
	<i>RMB'000</i>	<i>RMB'000</i>	<i>RMB'000</i>	<i>RMB'000</i>	<i>RMB'000</i>
<b>Executive directors</b>					
Hu Xiang	—	—	540	8	548
Wang Guoying	—	7	476	4	487
<b>Non-executive directors</b>					
Qu Deqian	—	—	—	1	1
Xing Qibin	—	—	—	1	1
Yan Andrew Y.	—	—	—	1	1
Yang Dong	—	—	24	1	25
Li Tianshu	—	—	30	—	30
	<u>—</u>	<u>7</u>	<u>1,070</u>	<u>16</u>	<u>1,093</u>

## For the year ended 31st December 2008

	Fees	Retirement benefits scheme contributions	Other emoluments (mainly basic salaries, bonus and allowances)	Equity- settled share-based payment expenses	Total
	<i>RMB'000</i>	<i>RMB'000</i>	<i>RMB'000</i>	<i>RMB'000</i>	<i>RMB'000</i>
<b>Executive directors</b>					
Hu Xiang	—	—	758	—	758
Wang Guoying	—	10	643	—	653
<b>Non-executive directors</b>					
Qu Deqian	—	—	—	—	—
Xing Qibin	—	—	—	—	—
Yan Andrew Y.	—	—	—	—	—
Yang Dong	—	—	24	—	24
Li Tianshu	—	—	60	—	60
	<u>—</u>	<u>10</u>	<u>1,485</u>	<u>—</u>	<u>1,495</u>

## For the eight months ended 31st August 2008 (unaudited)

	Fees	Retirement benefits scheme contributions	Other emoluments (mainly basic salaries, bonus and allowances)	Equity- settled share-based payment expenses	Total
	<i>RMB'000</i>	<i>RMB'000</i>	<i>RMB'000</i>	<i>RMB'000</i>	<i>RMB'000</i>
<b>Executive directors</b>					
Hu Xiang	—	—	429	—	429
Wang Guoying	—	6	366	—	372
<b>Non-executive directors</b>					
Qu Deqian	—	—	—	—	—
Xing Qibin	—	—	—	—	—
Yan Andrew Y.	—	—	—	—	—
Yang Dong	—	—	16	—	16
Li Tianshu	—	—	40	—	40
	<u>—</u>	<u>6</u>	<u>851</u>	<u>—</u>	<u>857</u>

## For the eight months ended 31st August 2009

	Fees	Retirement	Other	Equity-	Total
	RMB'000	contributions	emoluments	settled	RMB'000
		RMB'000	(mainly	share-based	
			basic	payment	
			salaries,	expenses	
			bonus and	RMB'000	
			allowances)	RMB'000	
			RMB'000	RMB'000	RMB'000
<b>Executive directors</b>					
Hu Xiang	—	—	450	—	450
Wang Guoying	—	8	403	—	411
<b>Non-executive directors</b>					
Qu Deqian	—	—	—	—	—
Xing Qibin	—	—	—	—	—
Yan Andrew Y.	—	—	—	—	—
Yang Dong	—	—	16	—	16
Li Tianshu	—	—	40	—	40
	—	8	909	—	917

During the Relevant Periods, no emoluments were paid by the Group to the directors or the five highest paid individuals as an inducement to join or upon joining the Group or as compensation for loss of office. None of the directors or the five highest paid individuals has waived any emoluments during the Relevant Periods.

The five highest paid individuals included two directors for the three years ended 31st December 2006, 2007, 2008 and for the eight months ended 31st August 2008 (unaudited) and 31st August 2009, details of whose emoluments are set out above. The emoluments of the remaining three highest paid individuals for the three years ended 31st December 2006, 2007, 2008 and for the eight months ended 31st August 2008 (unaudited) and 31st August 2009 are as follows:

	Year ended 31st December			Eight months ended	
	2006	2007	2008	2008	2009
	RMB'000	RMB'000	RMB'000	RMB'000	RMB'000
				(unaudited)	
<b>Employees</b>					
- basic salaries and allowances	1,587	1,684	1,474	760	944
- retirement benefits scheme contributions	3	13	27	17	24
- equity-settled share-based payment expenses	149	65	44	28	26
	1,739	1,762	1,545	805	994

Their emoluments were individually within RMB1,000,000.

## 13. DIVIDENDS

	Year ended 31st December			Eight months ended	
	2006	2007	2008	31st August 2008	2009
	RMB'000	RMB'000	RMB'000	RMB'000	RMB'000
Dividends recognised as distribution during the year/period:					
2005 dividend of RMB 0.07965 per ordinary share	5,934	—	—	—	—
2007 first dividend of RMB0.1424 per ordinary share	—	—	10,641	10,641	—
2007 second dividend of RMB0.1424 per ordinary share	—	—	—	—	10,641
2005 dividend of RMB 0.07965 per Series A preferred share	2,031	—	—	—	—
2007 first dividend of RMB0.1424 per Series A preferred share	—	—	4,359	4,359	—
2007 second dividend of RMB0.1424 per Series A preferred share	—	—	—	—	4,359
	<u>7,965</u>	<u>—</u>	<u>15,000</u>	<u>15,000</u>	<u>15,000</u>

## 14. EARNINGS PER SHARE

The earning figures for calculation of basic and diluted earnings per share attributable to the ordinary owners of the Company are based on the following data:

	Year ended 31st December			Eight months ended	
	2006	2007	2008	31st August 2008	2009
	RMB'000	RMB'000	RMB'000	RMB'000	RMB'000
<b>Earnings</b>					
Profit for the year/period and attributable to owners of the Company	31,481	56,773	61,925	37,348	84,205
Less:					
2005 dividend of RMB 0.07965 per Series A preferred share	(2,031)	—	—	—	—
2007 first dividend of RMB0.1424 per Series A preferred share	—	—	(4,359)	(4,359)	—
2007 second dividend of RMB0.1424 per Series A preferred share	—	—	—	—	(4,359)
Earnings for purpose of basic earnings per share	<u>29,450</u>	<u>56,773</u>	<u>57,566</u>	<u>32,989</u>	<u>79,846</u>

	Year ended 31st December			Eight months ended	
	2006	2007	2008	31st August 2008	2009
	RMB'000	RMB'000	RMB'000	RMB'000	RMB'000
Effect of dilutive potential ordinary shares:					
2005 dividend of RMB 0.07965 per Series A preferred share	2,031	—	—	—	—
2007 first dividend of RMB0.1424 per Series A preferred share	—	—	4,359	4,359	—
2007 second dividend of RMB0.1424 per Series A preferred share	—	—	—	—	4,359
Earnings for purpose of diluted earnings per share	<u>31,481</u>	<u>56,773</u>	<u>61,925</u>	<u>37,348</u>	<u>84,205</u>
	'000	'000	'000	'000	'000

**Number of shares**

Weighted average number of ordinary shares for the purposes of basic earnings per share	372,500	373,232	373,543	373,543	373,543
Effect of dilutive potential ordinary shares					
- Conversion of Series A preferred shares	127,500	145,385	153,000	153,000	153,000
- Warrant for purchases of ordinary shares	1,045	312	—	—	—
- Warrant for purchases of Series A preferred shares	16,474	4,943	—	—	—
- 2003 share options	7,750	8,925	7,411	9,592	10,661
- 2005 share options	176	1,608	—	2,654	5,936
Weighted average number of ordinary shares for the purpose of diluted earnings per share	<u>525,445</u>	<u>534,405</u>	<u>533,954</u>	<u>538,789</u>	<u>543,140</u>

The computation of diluted earnings per share, which is based on the fair value of the ordinary shares estimated by the Company's directors except for Series A preferred shares, does not assume the conversion of the Company's outstanding 2005 share options for the year ended 31st December 2008 since the effect of their exercise on earnings per share is anti-dilutive.

The weighted average number of ordinary shares for the purpose of earnings per share has been prepared based on the assumption that the capitalisation issue pursuant to a shareholder resolution passed on 25th November 2009 had been effective on 1st January 2006.

## 15. PROPERTY, PLANT AND EQUIPMENT

## The Group

	Buildings RMB'000	Furniture fixtures and equipment RMB'000	Leasehold improvements RMB'000	Motor vehicles RMB'000	Plant and machinery RMB'000	Construction in progress RMB'000	Total RMB'000
<b>COST</b>							
At 1st January 2006	—	2,402	1,474	1,609	25,504	6,874	37,863
Additions	—	1,102	197	759	7,834	39,674	49,566
Transfer	46,548	—	—	—	—	(46,548)	—
Disposals	—	(72)	—	—	—	—	(72)
At 31st December 2006	46,548	3,432	1,671	2,368	33,338	—	87,357
Additions	—	2,856	287	571	23,672	1,325	28,711
Transfer	864	—	—	—	—	(864)	—
Disposals	—	(34)	—	—	—	—	(34)
At 31st December 2007	47,412	6,254	1,958	2,939	57,010	461	116,034
Additions	10,758	1,485	—	276	17,654	1,794	31,967
Disposals	—	(70)	—	(68)	(34)	—	(172)
At 31st December 2008	58,170	7,669	1,958	3,147	74,630	2,255	147,829
Additions	417	834	681	674	11,895	5,769	20,270
Disposals	—	(373)	(197)	—	(194)	(15)	(779)
At 31st August 2009	58,587	8,130	2,442	3,821	86,331	8,009	167,320
<b>ACCUMULATED DEPRECIATION</b>							
At 1st January 2006	—	1,009	1,466	745	8,393	—	11,613
Provided for the year	—	412	82	348	4,714	—	5,556
Eliminated on disposals	—	(65)	—	—	—	—	(65)
At 31st December 2006	—	1,356	1,548	1,093	13,107	—	17,104
Provided for the year	1,422	978	121	427	6,972	—	9,920
Eliminated on disposals	—	(19)	—	—	—	—	(19)
At 31st December 2007	1,422	2,315	1,669	1,520	20,079	—	27,005
Provided for the year	1,575	1,208	144	439	10,105	—	13,471
Eliminated on disposals	—	(34)	—	(65)	(32)	—	(131)
At 31st December 2008	2,997	3,489	1,813	1,894	30,152	—	40,345
Provided for the period	1,156	840	23	266	7,625	—	9,910
Eliminated on disposals	—	(334)	(197)	—	(115)	—	(646)
At 31st August 2009	4,153	3,995	1,639	2,160	37,662	—	49,609
<b>NET BOOK VALUES</b>							
At 31st December 2006	46,548	2,076	123	1,275	20,231	—	70,253
At 31st December 2007	45,990	3,939	289	1,419	36,931	461	89,029
At 31st December 2008	55,173	4,180	145	1,253	44,478	2,255	107,484
At 31st August 2009	54,434	4,135	803	1,661	48,669	8,009	117,711

Depreciation is provided to write off the cost of items of property, plant and equipment other than construction in progress over their estimated useful lives and after taking into account of their estimated residual value, using straight-line method, at the following rates per annum:

Buildings	Over the shorter of the term of lease or 50 years
Furniture, fixtures and equipment	19%
Leasehold improvements	50%
Motor vehicles	19%
Plant and machinery	9.5% - 19%

The Group's buildings which are situated in the PRC are erected on medium-term land use rights.

## 16. PREPAID LEASE PAYMENTS

### The Group

	At 31st December			At 31st August
	2006	2007	2008	2009
	RMB'000	RMB'000	RMB'000	RMB'000
Land use rights in the PRC				
Medium term lease	4,422	4,331	22,041	21,756
Analysed for reporting purposes as:				
Current portion	98	98	471	453
Non-current portion	4,324	4,233	21,570	21,303
	<u>4,422</u>	<u>4,331</u>	<u>22,041</u>	<u>21,756</u>

## 17. INVESTMENTS IN SUBSIDIARIES/AMOUNT DUE FROM A SUBSIDIARY

### The Company

	At 31st December			At 31st August
	2006	2007	2008	2009
	RMB'000	RMB'000	RMB'000	RMB'000
Investments at cost:				
Capital contribution	<u>30,599</u>	<u>31,492</u>	<u>32,294</u>	<u>32,785</u>

The capital contribution at 31st August 2009 included amount of share-based payment of RMB4,785,000 (31st December 2008: RMB4,294,000, 31st December 2007: RMB3,492,000, 31st December 2006: RMB2,599,000) in respect of share options of the Company granted to the employees of a subsidiary for their service provided to that subsidiary.

The amount due from a subsidiary is unsecured, interest-free and expected to recover within 12 months from the respective reporting period end.

## 18. DEFERRED TAX

## The Group

	Allowance for inventories <i>RMB'000</i>	Excess of accounting depreciation over tax depreciation <i>RMB'000</i>	Allowance for doubtful debts <i>RMB'000</i>	Provision <i>RMB'000</i>	Unrealised profit of inter-company sales <i>RMB'000</i>	Total <i>RMB'000</i>
At 1st January 2006 and 31st December 2006	—	—	—	—	—	—
Credit to consolidated statement of comprehensive income for the year	—	1,297	140	90	—	1,527
At 31st December 2007	—	1,297	140	90	—	1,527
Credit to consolidated statement of comprehensive income for the year	—	1,771	69	—	2,651	4,491
Effect of change in tax rate	—	—	(3)	(15)	—	(18)
At 31st December 2008	—	3,068	206	75	2,651	6,000
Credit to consolidated statement of comprehensive income for the period	108	638	—	—	638	1,384
At 31st August 2009	108	3,706	206	75	3,289	7,384

The deferred tax asset as shown on the consolidated statement of financial position is nil, RMB1,527,000, RMB6,000,000, RMB7,384,000 as at 31st December 2006, 31st December 2007, 31st December 2008 and 31st August 2009 respectively.

Unrecognised deferred tax assets:

	At 31st December			At 31st August
	2006	2007	2008	2009
	<i>RMB'000</i>	<i>RMB'000</i>	<i>RMB'000</i>	<i>RMB'000</i>
Tax losses with expiry in:				
- 2013	—	—	4,131	4,131
- 2014	—	—	—	2,352
	—	—	4,131	6,483

No deferred tax asset has been recognised due to the unpredictability of future profit streams.

Under the New Law of PRC, withholding tax is imposed on dividends declared in respect of profits earned by PRC subsidiaries from 1 January 2008 onwards. Deferred taxation has not been provided for in the consolidated statement of comprehensive income in respect of temporary differences attributable to accumulated profits of the PRC subsidiaries as at 31st August 2009 amounting to RMB172,354,000 (31st December 2008: RMB81,435,000) as the Group is able to control the timing of the reversal of the temporary differences and it is probable that the temporary differences will not reverse in the foreseeable future.

### The Company

The Company was incorporated in the Cayman Islands and there is no temporary difference as it is exempted from income tax in the Cayman Islands and elsewhere in other jurisdictions.

## 19. INVENTORIES

	At 31st December			At 31st
	2006	2007	2008	August
	RMB'000	RMB'000	RMB'000	2009
				RMB'000
<b>The Group</b>				
Raw materials	12,840	46,534	50,192	63,612
Work-in-progress	3,926	19,020	20,303	35,336
Finished goods	35,042	61,888	151,554	191,819
	<u>51,808</u>	<u>127,442</u>	<u>222,049</u>	<u>290,767</u>

## 20. TRADE AND OTHER RECEIVABLES

	At 31st December			At 31st
	2006	2007	2008	August
	RMB'000	RMB'000	RMB'000	2009
				RMB'000
<b>The Group</b>				
Trade receivables	145,057	206,707	206,895	314,096
Less: allowance for doubtful debts	(137)	(919)	(1,371)	(1,371)
	<u>144,920</u>	<u>205,788</u>	<u>205,524</u>	<u>312,725</u>
Notes receivable	54,612	58,565	142,319	187,688
Rental and utility deposits	597	893	778	894
Advance to suppliers	3,837	3,366	4,994	3,585
Other receivables and prepayments	1,916	12,135	8,544	9,010
	<u>205,882</u>	<u>280,747</u>	<u>362,159</u>	<u>513,902</u>
<b>The Company</b>				
Other receivables and prepayments	—	3,444	5,586	5,584
	<u>—</u>	<u>3,444</u>	<u>5,586</u>	<u>5,584</u>

## Movement in the allowance for doubtful debts

	Year ended 31st December			Eight months ended 31st August	
	2006	2007	2008	2008	2009
	RMB'000	RMB'000	RMB'000	RMB'000	RMB'000
				<i>(Unaudited)</i>	
Balance at beginning of year/period	329	137	919	919	1,371
Amounts recovered during the year/period	(192)	—	—	—	—
Increase in the allowance recognised in profit or loss	—	782	452	452	—
Balance at end of the year/period	<u>137</u>	<u>919</u>	<u>1,371</u>	<u>1,371</u>	<u>1,371</u>

Included in the allowance for doubtful debts are individually impaired trade receivables with an aggregate balance of approximately RMB137,000, RMB919,000, RMB1,371,000 and RMB1,371,000 as at 31st December 2006, 31st December 2007, 31st December 2008 and 31st August 2009, respectively, which have defaulted on payment. The Company considers that the recoverability of these receivables is low and therefore allowance for bad and doubtful debts has been provided. The Group does not hold any collateral over these balances.

The Group offers credit terms generally accepted in the antenna system, base station RF subsystem and coverage extension solution manufacturing industry to its trade customers, which for a significant number of the Company's products is around 30 to 120 days, although a longer credit term may be extended to certain customers, depending on price, the size of the contract, credibility and reputation of the customers. In order to manage the credit risks associated with trade receivables effectively, credit limits of customers are evaluated periodically.

The following is an aged analysis based on invoice date of trade receivables net of impairment losses at the end of each reporting period:

Age	At 31st December			At 31st August
	2006	2007	2008	2009
	RMB'000	RMB'000	RMB'000	RMB'000
0 to 30 days	63,375	66,350	85,521	77,470
31 to 60 days	30,135	75,335	39,049	71,558
61 to 90 days	10,589	16,543	14,036	38,724
91 to 120 days	6,102	5,287	36,017	34,731
121 to 180 days	4,651	8,140	5,161	24,923
Over 180 days	30,068	34,133	25,740	65,319
	<u>144,920</u>	<u>205,788</u>	<u>205,524</u>	<u>312,725</u>

The following is an aged analysis based on invoice date of notes receivables at the end of each reporting period:

	At 31st December			At 31st
	2006	2007	2008	August
	RMB'000	RMB'000	RMB'000	2009
0 to 30 days	28,587	20,595	39,603	41,637
31 to 60 days	12,909	21,770	28,876	31,649
61 to 90 days	13,116	15,200	26,834	35,608
Over 90 days	—	1,000	47,006	78,794
	<u>54,612</u>	<u>58,565</u>	<u>142,319</u>	<u>187,688</u>

Ageing based on credit period of trade receivables which are past due but not impaired:

Age	At 31st December			At 31st
	2006	2007	2008	August
	RMB'000	RMB'000	RMB'000	2009
0 to 30 days	—	101	88	—
31 to 60 days	74	53	20	168
61 to 90 days	505	36	353	414
90 to 120 days	1,400	—	8	95
121 to 180 days	8	1,733	1,198	101
Over 180 days	<u>4,103</u>	<u>1,680</u>	<u>1,767</u>	<u>3,916</u>
Total	<u>6,090</u>	<u>3,603</u>	<u>3,434</u>	<u>4,694</u>

The Group does not hold any collateral over these balances. The average age of these receivables as at 31st December 2006, 31st December 2007, 31st December 2008 and 31st August 2009 is 122 days, 102 days, 113 days and 99 days respectively.

The Group's trade receivables of RMB9,009,000, RMB53,212,000, RMB39,056,000 and RMB24,924,000 at 31st December 2006, 31st December 2007, 31st December 2008 and 31st August 2009, respectively, were denominated in USD and EUR, foreign currencies of respective group entities.

## 21. PLEDGED BANK BALANCES/ BANK BALANCES AND CASH/ENTRUSTED LOAN

The Group's pledged bank balances represent bank deposits for 3 months to one year which carry fixed rate interest ranging from 1.71% to 3.33% per annum during the Relevant Periods. They are pledged to banks to secure banking facilities granted to the Group and notes payables of the Group. Included in the 31st December 2007 balance is a RMB2,000,000 bank deposit pledged to a bank for an interest-free entrusted loan of RMB5,000,000 from 深圳市高新技術投資擔保有限公司, an independent third party to MOBI Shenzhen (as a high technology company engaged in the industry sector in Shenzhen), to facilitate the development of the technology of MOBI Shenzhen. The interest-free entrusted loan was settled on 22nd March 2008.

The Group's bank balances and cash comprise cash and bank deposits which carry interest at prevailing market rates ranging from 0.36% to 0.81% per annum during the Relevant Periods.

Certain of the Group's pledged bank balance and bank balances and cash with an aggregate amount of RMB20,285,000, RMB87,565,000, RMB58,794,000 and RMB100,318,000 at 31st December 2006, 31st December 2007, 31st December 2008 and 31st August 2009, respectively, were denominated in RMB which is not a freely convertible currency in the international market. The government of the PRC has implemented foreign exchange control and the remittance of these funds out of the PRC is subject to exchange restrictions imposed by the government of the PRC.

Certain of the Group's bank balances and cash of RMB24,103,000, RMB51,911,000, RMB15,012,000 and RMB10,477,000 at 31st December 2006, 31st December, 2007, 31st December 2008 and 31st August 2009, respectively, were denominated in USD, EUR and HKD, foreign currencies of respective group entities.

The Company's bank balances and cash of RMB16,593,000, RMB11,960,000, RMB9,675,000 and RMB8,718,000 at 31st December 2006, 31st December 2007, 31st December 2008 and 31st August 2009, respectively, were denominated in USD and HKD, foreign currencies of the Company.

## 22. TRADE AND OTHER PAYABLES

	At 31st December			At 31st
	2006	2007	2008	August
	RMB'000	RMB'000	RMB'000	2009
				RMB'000
<b>The Group</b>				
Trade payables	108,758	230,303	198,476	315,460
Notes payable	13,083	17,558	138,123	135,613
Payroll payable	11,671	13,389	15,585	14,361
Payable for acquisition of property, plant and equipment	8,669	2,705	2,230	1,320
Other taxes payable	3,898	165	3,799	2,414
Accrued expenses	3,456	15,168	17,250	16,515
Refundable government grants (note)	2,628	992	992	—
Others	1,164	1,220	3,856	4,687
	<u>153,327</u>	<u>281,500</u>	<u>380,311</u>	<u>490,370</u>
<b>The Company</b>				
Accrued expenses	—	4,445	4,151	3,862
Others	2	2	2	2
	<u>2</u>	<u>4,447</u>	<u>4,153</u>	<u>3,864</u>

*Note:* Refundable government grants are recorded as other payables as the unutilised amount would be refunded to the government. When the Group has utilised the amount for depreciable assets, the related amount is then transferred to and presented as deferred income and released to consolidated statement of comprehensive income in accordance with the Group's accounting policy.

The following is an aged analysis based on invoice date of trade payables at the end of each reporting period:

Age	At 31st December			At 31st August
	2006	2007	2008	2009
	RMB'000	RMB'000	RMB'000	RMB'000
<b>The Group</b>				
0 to 30 days	29,552	29,679	63,063	40,636
31 to 60 days	29,730	37,009	36,677	40,382
61 to 90 days	17,730	38,336	40,099	42,713
91 to 180 days	29,867	124,244	55,409	153,479
Over 180 days	1,879	1,035	3,228	38,250
	<u>108,758</u>	<u>230,303</u>	<u>198,476</u>	<u>315,460</u>

Typical credit term of trade payable is 90 days.

The following is an aged analysis based on invoice date of notes payables at the end of each reporting period:

Age	At 31st December			At 31st August
	2006	2007	2008	2009
	RMB'000	RMB'000	RMB'000	RMB'000
<b>The Group</b>				
0 to 30 days	10,783	4,500	35,087	—
31 to 60 days	—	6,500	48,644	54,659
61 to 90 days	2,300	6,558	54,392	80,954
	<u>13,083</u>	<u>17,558</u>	<u>138,123</u>	<u>135,613</u>

All notes payable are repayable within 90 days.

### 23. SHORT-TERM BANK BORROWINGS

#### The Group

Categories	At 31st December			At 31st August
	2006	2007	2008	2009
	RMB'000	RMB'000	RMB'000	RMB'000
Secured				
- Fixed rate	7,909	24,500	23,454	35,609
- Floating rate	—	—	—	13,135
Unsecured				
- Fixed rate	—	—	10,000	59,000
- Floating rate	—	45,000	40,000	50,000
	<u>7,909</u>	<u>69,500</u>	<u>73,454</u>	<u>157,744</u>

The only bank borrowings denominated in foreign currency are the short-term secured floating rate bank borrowings as at 31st August 2009, which are denominated in USD and carry at prevailing market interest rates of 1.39% per annum. The short-term secured fixed rate bank borrowings carry fixed interest rates ranging from 1.39% to 7.67% per annum during the Relevant Periods. The short-term secured bank borrowing as at 31st August, 2009 are secured by notes receivable and bank deposit of approximately RMB48,744,000 (31st December 2008: by notes receivable of approximately RMB23,454,000, 31st December 2007: by receivables of approximately RMB24,500,000, 31st December 2006: by notes receivable of approximately RMB7,909,000). The related trade and note receivables were discounted with recourse and therefore, they have not been derecognised at 31st December 2006, 2007 and 2008 and 31st August 2009.

The short-term unsecured floating rate bank borrowings carry at prevailing market interest rates linked to PBOC Rate of 4.62% to 7.47% per annum during the Relevant Periods. The short-term unsecured fixed rate bank borrowings and carry fixed interest rates ranging from 4.62% to 6.12% per annum during the Relevant Periods.

#### 24. DEFERRED INCOME

Deferred income represents non-recurring and non-conditional government grants received by MOBI Shenzhen and MOBI Jian in 2006, 2007, 2008 and 2009 from 深圳市財政局, 深圳市貿易工業局, 深圳市科技和資訊局, 吉安市人民政府, 吉安市財政局 and 深圳市南山區科學技術局, respectively, for acquisition and improvement of property, plant and equipment.

The deferred income is released to the consolidated statement of comprehensive income over the expected useful life of the relevant assets. Movements of deferred income during the Relevant Periods are as follows:

##### The Group

	At 31st December			At 31st
	2006	2007	2008	August
	RMB'000	RMB'000	RMB'000	2009
				RMB'000
<b>Government grant related to assets</b>				
At beginning of the year/period	—	1,351	3,799	3,236
Additions	1,369	2,560	—	2,030
Realised to consolidated statement of comprehensive income	(18)	(112)	(563)	(920)
At end of the year/period	<u>1,351</u>	<u>3,799</u>	<u>3,236</u>	<u>4,346</u>
Analysed for reporting purposes as:				
Current portion	54	563	563	746
Non-current portion	<u>1,297</u>	<u>3,236</u>	<u>2,673</u>	<u>3,600</u>
	<u>1,351</u>	<u>3,799</u>	<u>3,236</u>	<u>4,346</u>

#### 25. PROVISION

In December 2004, MOBI Shenzhen was alleged to have infringed a utility model patent of Guangdong Tongyu Communications Equipment Co., Ltd. (formerly known as Zhong Shan Tongyu Communications Equipment Co., Ltd.) ("Tongyu"), which utility model patent is a type of waterproof feeder structure for omni-directional antennas. Subsequently, MOBI Shenzhen made an application to the Patent Review Committee to invalidate that utility model patent. Thereafter, the Patent Review Committee invalidated Tongyu's utility model patent in part, which ruling was then upheld by The

Beijing First Intermediate People's Court and The Beijing Superior People's Court, respectively, within their jurisdiction. On 3rd September 2007, the Intermediate People's Court of Shenzhen issued a first instance verdict in the corresponding civil proceedings dismissing the allegation of patent infringement. On 30th September 2007, an appeal against such first instance verdict was filed with The Guangdong Superior People's Court. On 23rd June 2008, The Guangdong Superior People's Court affirmed the first instance decision and dismissed the allegation of patent infringement. MOBI Shenzhen was found not liable for any damages. On 15th September 2009, Tongyu filed an application for retrial with The Supreme People's Court of the PRC. On 2nd November 2009, MOBI Shenzhen received a notice date 16th October 2009 from The Supreme People's Court of the PRC stating that the said retrial application was accepted. In accordance with the retrial application, up to date of report, Tongyu sought to revoke the final civil judgment granted by the Guangdong Superior People's Court. Based on a legal opinion from a PRC lawyer that, the maximum amount of damage will not exceed that as claimed by Tongyu should the amount of profits of MOBI Shenzhen from the utility model is quantifiable or the maximum amount of damage will not exceed RMB500,000. The directors are in the view that the above said profits is not quantifiable and, accordingly, the Group may be exposed to a maximum potential liability of RMB500,000 in relation to the legal proceedings and a provision of RMB500,000 was made as at 31st December 2006, 2007 and 2008, and 31st August 2009.

## 26. ISSUED CAPITAL

### The Group and the Company

	Number of shares '000	Amount USD
<b>Authorised</b>		
Ordinary shares of par value of USD0.000001 each	750,000	750.00
Series A preferred shares of par value of USD0.000001 each	<u>50,000</u>	<u>50.00</u>
At 1st January 2006, 31st December 2006, 31st December 2007, 31st December 2008 and 31st August 2009	<u>800,000</u>	<u>800.00</u>
	<b>Number of shares '000</b>	<b>Amount USD</b>
<b>Issued and fully paid</b>		
Ordinary shares of par value of USD0.000001 each	74,500	74.50
Series A preferred shares of par value of USD0.000001 each	<u>25,500</u>	<u>25.50</u>
At 1st January 2006 and 31st December 2006	<u>100,000</u>	<u>100.00</u>
Increase on 20th April 2007:		
Ordinary shares of par value of USD0.000001 each	209	0.21
Series A preferred shares of par value of USD0.000001 each	<u>5,100</u>	<u>5.10</u>
	<u>5,309</u>	<u>5.31</u>
At 31st December 2007, 31st December 2008 and 31st August 2009	<u>105,309</u>	<u>105.31</u>
		<i>RMB'000</i>
Shown in the statements of financial position as at 31st December 2006, 31st December 2007, 31st December 2008 and 31st August 2009		<u>1</u>

Pursuant to a shareholder resolution passed on 25th November 2009, the following shall take place on the listing date: (i) 30,599,999 Series A preferred shares shall be converted into 30,599,999 ordinary shares of a nominal value of USD0.000001 each; (ii) 19,400,001 unissued Series A preferred shares shall be re-designated as ordinary shares of a nominal value of USD0.000001 each; and (iii) the authorised share capital of the Company shall be increased from USD800 divided into 800,000,000 ordinary and preferred shares of par value of USD0.000001 each to USD2,000 by the creation of an additional 1,200,000,000 ordinary shares of par value of USD0.000001 each.

Pursuant to a shareholder resolution passed on 25th November 2009, the directors were authorised to capitalise an aggregate amount of USD421.24 standing to the credit of the share premium of the Company and to appropriate such amount as capital to pay up in full at par 421,234,396 shares for allotment and issue to the persons whose names appear on the register of members of the Company at the close of business on 25th November 2009 in proportion to their then existing shareholdings in the Company, each ranking *pari passu* in all respects with the then existing issued shares.

### **Series A preferred shares**

Series A preferred shares shall be convertible at any time at the option of the holder into ordinary shares at RMB1.7647059 for each preferred share. Series A preferred shares shall also be automatically converted to ordinary shares at RMB1.7647059 per share upon a fully underwritten initial public offering of not less than USD6 million (before deduction of underwriters commissions and expenses) and with a pre-offering valuation of the Company of not less than USD30 million, which is estimated by the preferred shareholder by reference to the valuations of other publicly traded companies in the same sector of the Company, and the listing of the Company's ordinary shares on an internationally reputable stock exchange reasonably acceptable to holders of Series A preferred shares ("Qualified IPO").

The holder of each Series A preferred share has the number of votes equal to the number of ordinary shares into which such Series A preferred share could be converted to.

No dividends or other distributions shall be made or declared in property, or in any other shares of the Company, with respect to any other class or series of shares of the Company apart from the Series A preferred shares, unless and until dividends or distributions in like amount have been paid or distributed in full on the Series A preferred shares on an as converted basis.

In the event of any liquidation, dissolution or winding up of the Company, the Series A preferred shareholder shall be entitled to receive, prior and in preference to any distribution of any of the assets or surplus funds of the Company to the holders of the ordinary shares or any other class or series of shares, an amount equal to RMB1.7647059 for each Series A preferred share and, in addition, all declared but unpaid dividends ("Series A Preference Amount"). After full payment of the Series A Preference Amount in respect of each Series A preferred share, any remaining assets or surplus funds of the Company shall be distributed to holders of ordinary shares and Series A preferred shares *pro rata* on an as converted basis.

## Warrants

On the date of incorporation of the Company, the Company issued to the Series A preferred shareholder a warrant, under which the Series A preferred shareholder is entitled to purchase from the Company additional Series A preferred shares equals to aggregate par value of RMB9,000,000 divided by the exercise price, subject to anti-dilutive adjustment from time to time. The initial exercise price is RMB1.7647059. The Company also issued warrants to an ordinary shareholder, under which the ordinary shareholder is entitled to purchase from the Company 208,600 ordinary shares at a nominal price.

During the year ended 31st December 2007, the Series A preferred shareholder exercised its right to subscribe for 5,099,999 Series A preferred shares in the Company at the total purchase price of RMB9,000,000 (with an exercise price of RMB1.7647059 per share), and the ordinary shareholders exercised their rights to subscribe for 208,600 ordinary shares in the Company at the nominal price.

## 27. SHARE-BASED PAYMENT TRANSACTIONS

Share options were granted on 15th January 2003 (“2003 Option”) and 31st August 2005 (“2005 Option”) for the primary purpose of providing incentives to directors and eligible employees, and will expire on 15th January 2013 and 31st August 2015 respectively. Under the share option schemes of the Company, the Board of Directors of the Company may grant options to eligible employees, including directors of the Company and its subsidiaries, to subscribe for shares in the Company. Additionally, the Company may, from time to time, grant share options to an individual consultant or advisor who renders or has rendered bona fide services to the Company.

At 31st August 2009, the number of ordinary shares in respect of which options had been granted and remained outstanding under 2003 Option and 2005 Option was 5,124,000 (31st December 2008: 5,265,000, 31st December 2007: 5,332,500, 31st December 2006: 5,332,500), representing 4.87% (31st December 2008:5.00%, 31st December 2007: 5.06%, 31st December 2006: 5.33%) of the total ordinary and preferred shares of the Company in issue at that date.

No consideration is payable on the grant of an option. Options may be exercised at any time from 12 months after the date of grant of the share options to the tenth anniversary of the date of grant.

Details of specific categories of options are as follows:

Option type	Date of grant	Vesting period	Exercisable period	Exercise price	Fair value at grant date
2003 Option	15/01/2003	15/01/2003 to 14/01/2007	15/01/2004 to 14/01/2013	RMB1.76	RMB0.95
2005 Option	31/08/2005	31/08/2005 to 30/08/2009	31/08/2006 to 30/08/2015	RMB3.66	RMB1.36

All 2003 Option and 2005 Option are exercisable as to 25% of the total number of options on the first anniversary date of grant, and as to the remaining 75% in 36 subsequently equal monthly installments commencing on the last day of the month following the month of the first anniversary date of grant.

The following table discloses movements of the Company's share options held by eligible persons during the period from 1st January 2009 to 31st August 2009:

Option type	Outstanding at 1.1.2009	Granted during the period	Exercised during the period	Forfeited during the period	Expired during the period	Outstanding at 31.8.2009
2003 Option	2,750,000	—	—	—	—	2,750,000
2005 Option	2,515,500	—	—	141,500	—	2,374,000
	<u>5,265,500</u>	<u>—</u>	<u>—</u>	<u>141,500</u>	<u>—</u>	<u>5,124,000</u>
Exercisable at the end of the period						<u>5,124,000</u>
Exercise price						
2003 Option	<u>RMB1.76</u>	<u>—</u>	<u>—</u>	<u>—</u>	<u>—</u>	<u>RMB1.76</u>
2005 Option	<u>RMB3.66</u>	<u>—</u>	<u>—</u>	<u>RMB3.66</u>	<u>—</u>	<u>RMB3.66</u>

The following table discloses movements of the Company's share options held by eligible persons during 2008:

Option type	Outstanding at 1.1.2008	Granted during the period	Exercised during the period	Forfeited during the period	Expired during the period	Outstanding at 31.12.2008
2003 Option	2,750,000	—	—	—	—	2,750,000
2005 Option	2,582,500	—	—	67,000	—	2,515,500
	<u>5,332,500</u>	<u>—</u>	<u>—</u>	<u>67,000</u>	<u>—</u>	<u>5,265,500</u>
Exercisable at the end of the year						<u>4,835,083</u>
Exercise price						
2003 Option	<u>RMB1.76</u>	<u>—</u>	<u>—</u>	<u>—</u>	<u>—</u>	<u>RMB1.76</u>
2005 Option	<u>RMB3.66</u>	<u>—</u>	<u>—</u>	<u>RMB3.66</u>	<u>—</u>	<u>RMB3.66</u>

The following table discloses movements of the Company's share options held by eligible persons during 2007:

Option type	Outstanding at 1.1.2007	Granted during the period	Exercised during the period	Forfeited during the period	Expired during the period	Outstanding at 31.12.2007
2003 Option	2,750,000	—	—	—	—	2,750,000
2005 Option	2,582,500	—	—	—	—	2,582,500
	<u>5,332,500</u>	<u>—</u>	<u>—</u>	<u>—</u>	<u>—</u>	<u>5,332,500</u>
Exercisable at the end of the year						<u>4,256,458</u>
Exercise price						
2003 Option	<u>RMB1.76</u>	<u>—</u>	<u>—</u>	<u>—</u>	<u>—</u>	<u>RMB1.76</u>
2005 Option	<u>RMB3.66</u>	<u>—</u>	<u>—</u>	<u>—</u>	<u>—</u>	<u>RMB3.66</u>

The following table discloses movements of the Company's share options held by eligible persons during 2006:

Option type	Outstanding at 1.1.2006	Granted during the period	Exercised during the period	Forfeited during the period	Expired during the period	Outstanding at 31.12.2006
2003 Option	2,750,000	—	—	—	—	2,750,000
2005 Option	2,582,500	—	—	—	—	2,582,500
	<u>5,332,500</u>	<u>—</u>	<u>—</u>	<u>—</u>	<u>—</u>	<u>5,332,500</u>
Exercisable at the end of the year						<u>3,610,833</u>
Exercise price						
2003 Option	<u>RMB1.76</u>	<u>—</u>	<u>—</u>	<u>—</u>	<u>—</u>	<u>RMB1.76</u>
2005 Option	<u>RMB3.66</u>	<u>—</u>	<u>—</u>	<u>—</u>	<u>—</u>	<u>RMB3.66</u>

The 2003 Option and 2005 Option were granted on 15th January 2003 and 31st August 2005, respectively, with estimated fair value on the grant date of RMB0.95 and RMB1.36, respectively.

These fair values were calculated using the Black-Scholes option pricing model. The inputs into the model were as follows:

	2003 Option	2005 Option
Fair value of ordinary share	RMB1.76	RMB3.66
Exercise price	RMB1.76	RMB3.66
Expected volatility	78.00%	45.00%
Expected life	5 years	6 years
Risk-free rate	3.91%	4.57%
Expected dividend yield	3.00%	3.00%

Expected volatility was determined by using the historical volatility of the comparable companies' share prices over the previous 260 trading days. The expected life used in the model has been adjusted, based on management's best estimate, for the effects of non transferability, exercise restrictions and behavioural considerations.

In relation to share options granted by the Company, the Group recognised the total expense of RMB1,531,000, RMB905,000 and RMB802,000 for each of the three years ended 31st December 2008 respectively and RMB556,000 (unaudited) and RMB491,000 for the eight months ended 31st August 2008 and the eight months ended 31st August 2009 respectively as research and development costs, distribution and selling expenses as well as administrative expenses.

**28. OPERATING LEASE ARRANGEMENTS****The Group as lessee**

At the end of each reporting period, the Group was committed to make the following future minimum lease payments in respect of rented premises under non-cancellable operating leases which fall due as follows:

	At 31st December			At 31st
	2006	2007	2008	August
	RMB'000	RMB'000	RMB'000	2009
				RMB'000
Within one year	5,223	4,152	5,031	9,403
In the second to fifth year inclusive	5,170	3,463	1,848	26,657
	<u>10,393</u>	<u>7,615</u>	<u>6,879</u>	<u>36,060</u>

Leases are negotiated and rentals are fixed for lease terms of one to five years.

**29. CAPITAL COMMITMENTS**

	At 31st December			At 31st
	2006	2007	2008	August
	RMB'000	RMB'000	RMB'000	2009
				RMB'000
Capital expenditure contracted for but not provided in the Financial Information in respect of the acquisition of property, plant and equipment	<u>2,681</u>	<u>3,703</u>	<u>3,310</u>	<u>2,459</u>

**30. RETIREMENT BENEFITS SCHEME**

The employees of the Group are members of a state-managed retirement benefit scheme operated by the local government. MOBI Shenzhen, MOBI Jian and MOBI Xian are required to contribute 10%, 20% and 20%, respectively, of the payroll costs to the retirement benefit scheme to fund the benefits. The only obligation of these entities with respect to the retirement benefit scheme is to make the specified contributions.

The retirement benefits scheme contributions made by the Group amounted to RMB1,092,000, RMB1,701,000 and RMB2,533,000 for each of the three years ended 31st December 2008 respectively and RMB2,019,000 (unaudited) and RMB 3,358,000 for the eight months ended 31st August 2008 and the eight months ended 31st August 2009 respectively.

## 31. RELATED PARTY TRANSACTIONS

- (a) During the Relevant Periods, the Group has the following significant transactions with Shenzhen Weixiantong Shebei Co., Ltd. (深圳市中興維先通設備有限公司) which is controlled by the following common controlling shareholders of the Company:

	<b>Equity interest in the Company during the period from 1st January 2006 to 19th April 2007</b>	<b>Equity interest in the Company during the period from 20th April 2007 to 31st August 2009</b>	<b>Equity interest in Shenzhen Weixiantong Shebei Co., Ltd. during the Relevant Periods</b>
	%	%	%
Hou Weigui	7.51	7.17	18.00
Yin Yimin	2.09	2.00	5.00
Zhu Jinwen	2.09	2.00	5.00
Jiang Shumin	1.25	1.19	3.00
Shi Lirong	1.25	1.19	3.00
Tang Xi	1.25	1.19	3.00
Wang Honghai	1.25	1.19	3.00
Yu Wancheng	1.25	1.19	3.00
Zhou Susu	1.25	1.19	3.00
Zhu Weimin	1.25	1.19	3.00
Wei Zaisheng	1.25	1.19	3.00
Wei Xingmin	1.25	1.19	3.00
He Shiyong	0.88	0.84	2.10
Hu Xiang	5.50	5.23	2.10
Hong Bo	0.83	0.80	2.00
Liang Huming	0.83	0.80	2.00
Qu Deqian	0.83	0.80	2.00
Zhang Yan	0.83	0.80	2.00
Han Wei	0.83	0.80	2.00
Lai Yongxiang	0.83	0.80	2.00
Song Zhongshen	0.83	0.80	2.00
Gao Xueping	0.75	0.72	1.80
Bai Qi	0.63	0.60	1.50
Cui Yulong	0.63	0.60	1.50
Li Li	0.63	0.60	1.50
Wei Wangmin	0.63	0.60	1.50
Xing Qibin	0.63	0.60	1.50
Yao Dongwei	0.63	0.60	1.50
Zhang Dengsheng	0.63	0.60	1.50
Cheng Xiao	0.63	0.60	1.50
Hou Li	0.63	0.60	1.50
Li Yuehua	0.63	0.60	1.50
Shen Guohong	0.63	0.60	1.50
Tian Weibing	0.63	0.60	1.50
Xu Hanwu	0.63	0.60	1.50
Zhang Chuanhai	0.63	0.60	1.50
Zhang Diande	0.63	0.60	1.50
Zhou Qingjun	0.63	0.60	1.50
Liu Weihua	0.42	0.40	1.00
Total	<u>46.38</u>	<u>44.27</u>	<u>100.00</u>

The significant transaction between the Group and Shenzhen Weixiantong Shebei Co., Ltd. are as follows:

Nature of transactions	Year ended 31st December			Eight months ended 31st August	
	2006	2007	2008	2008	2009
	RMB'000	RMB'000	RMB'000	RMB'000	RMB'000
				<i>(unaudited)</i>	
Purchases of property, plant and equipment	550	—	150	—	—
Rental expenses	—	—	—	—	436
Related party balances	At 31st December			At 31st August	
	2006	2007	2008	2008	2009
	RMB'000	RMB'000	RMB'000	RMB'000	RMB'000
				<i>(unaudited)</i>	
Other receivables	—	101	209	209	209
Other payables	552	2	2	2	438

*Note: The balance is unsecured, interest-free and payable on demand.*

- (b) For the year ended 31st December 2006 and the period from 1st January to 15th June 2007, the Group has the following significant transactions with Shenzhen Kang Cheng Jixie Shebei Co., Ltd. (深圳市康鉞機械設備有限公司) which are under common key management personnel, namely Hu Xiang, Wang Guo Ying and Shao Zhi Guo, of the Group until 15th June 2007:

Nature of transactions	For the year ended 31st December 2006	Period from 1st January to 15th June 2007
	RMB'000	RMB'000
Purchases of raw materials	64,954	37,586
Related party balances		At 31st December 2006
		RMB'000
Trade payables		38,928

## (c) Compensation of key management personnel

The remuneration of directors and other members of key management during the Relevant Periods were as follows:

	Year ended 31st December			Eight months ended	
	2006	2007	2008	31st August 2008	2009
	RMB'000	RMB'000	RMB'000	RMB'000	RMB'000
				<i>(unaudited)</i>	
Short-term benefits	1,494	1,531	2,121	1,211	1,277
Post-employment benefits	8	13	19	11	16
Equity-settled share-based payment expenses	405	20	—	—	—
	<u>1,907</u>	<u>1,564</u>	<u>2,140</u>	<u>1,222</u>	<u>1,293</u>

The remuneration of directors and key executives is determined having regard to the performance of individuals and market trends.

The retirement benefits scheme contributions of one director were paid by Shenzhen Weixiantong Shebei Co., Ltd. during the Relevant Periods.

## (d) Directors' remuneration

Save as disclosed herein, no remuneration has been paid or is payable to the Company's directors by the Company or any of its subsidiaries during the Relevant Periods.

Under the arrangements presently in force, the aggregate remuneration of the Company's directors for the year ending 31st December 2009 is expected to be approximately RMB1,650,000.

**F. SUBSEQUENT EVENTS**

The following significant events took place subsequent to 31st August 2009:

- Pursuant to a shareholder resolution passed on 25th November 2009, the following shall take place on the listing date: (i) 30,599,999 Series A preferred shares shall be converted into 30,599,999 ordinary shares of a nominal value of USD0.000001 each; (ii) 19,400,001 unissued Series A preferred shares shall be re-designated as ordinary shares of a nominal value of USD0.000001 each; and (iii) the authorised share capital of the Company shall be increased from USD800 divided into 800,000,000 ordinary and preferred shares of par value of USD0.000001 each to USD2,000 by the creation of an additional 1,200,000,000 ordinary shares of par value of USD0.000001 each.
- Pursuant to a shareholder resolution passed on 25th November 2009, the directors were authorised to capitalise an aggregate amount of USD421.24 standing to the credit of the share premium of the Company and to appropriate such amount as capital to pay up in full at par 421,234,396 shares for allotment and issue to the persons whose names appear on the register of members of the Company at the close of business on 25th November 2009 in proportion to their then existing shareholdings in the Company, each ranking pari passu in all respects with the then existing issued shares.

**G. SUBSEQUENT FINANCIAL STATEMENTS**

No audited financial statements of the Group, the Company or any of its subsidiaries have been prepared in respect of any period subsequent to 31st August 2009.

Yours faithfully,  
**Deloitte Touche Tohmatsu**  
*Certified Public Accountants*  
Hong Kong

---

**APPENDIX II                      UNAUDITED PRO FORMA FINANCIAL INFORMATION**

---

**(A) UNAUDITED PRO FORMA STATEMENT OF ADJUSTED NET TANGIBLE ASSETS**

*For illustrative purpose only, the pro forma financial information prepared in accordance with Rule 4.29 of the Listing Rules is set out here to provide the investors with further information on how the Listing might have affected the financial position of the Group after completion of the Listing. Although reasonable care has been exercised in preparing the said information, prospective investors who read the information should bear in mind that these figures are inherently subject to adjustments and may not give a complete picture of the actual financial position of the Group after the completion of the Listing. The unaudited pro forma financial information should be read in conjunction with the section headed “Financial information” in this prospectus and the accountants’ report set forth in Appendix I to this prospectus.*

The following statement of our unaudited pro forma adjusted net tangible assets is based on the audited consolidated net tangible assets of the Group as at 31st August 2009, as shown in the Accountants’ Report, the text of which is set out in Appendix I to this prospectus, and adjusted as follows:

	<b>Audited consolidated net tangible assets attributable to owners of the Company as of August 31, 2009<sup>(1)</sup></b>	<b>Estimated net proceeds from the issue of Offer Shares<sup>(2)</sup> <i>(RMB in thousands)</i></b>	<b>Unaudited pro forma adjusted net tangible assets<sup>(3)</sup></b>	<b>Unaudited pro forma adjusted net tangible assets per Share<sup>(4)</sup> <i>(RMB)</i></b>	<b>Unaudited pro forma adjusted net tangible asset per Share<sup>(4)</sup> <i>(HK\$)</i></b>
Based on Offer Price of HK\$2.72 per share	397,272	389,262	786,534	1.12	1.28
Based on Offer Price of HK\$3.50 per share	397,272	506,038	903,310	1.29	1.47

*Notes:*

- (1) As of August 31, 2009, our audited consolidated net tangible assets attributable to owners of our Company was equal to equity attributable to owners of our Company extracted from the Accountants’ Report set out in Appendix I to this prospectus.
- (2) The estimated net proceeds from the Global Offering are based on the Offer Price of HK\$2.72 and HK\$3.50 per Offer Share, respectively, after deduction of the underwriting fees and other related expenses payable by us and assuming the translation of Hong Kong dollars to Renminbi with the exchange rate at RMB1.00 to HK\$1.14. No account has been taken on the Shares which may be issued pursuant to any exercise of the Over-allotment Option.
- (3) By comparing the valuation of our property interests (including an estimated capital value of RMB98,500,000 for property numbered 1 in Appendix IV based on certain assumptions set out in the valuation certificate therein) as of September 30, 2009 as set out in Appendix IV to this prospectus and the unaudited net book value of these properties as of September 30, 2009, the valuation surplus was approximately RMB63.3 million, which has not been included in the above net tangible assets. The valuation surplus of our property interests will not be incorporated in our future financial statements. If the valuation surplus were to be included in our future financial statements, an additional depreciation charge of approximately RMB1.3 million per annum would be incurred.
- (4) The unaudited pro forma adjusted net tangible assets per Share is based on a total of 702,057,995 Shares expected to be in issue immediately after the completion of the Global Offering (assuming no exercise of the Over-allotment Option) and assumes the translation of Hong Kong dollars to Renminbi with the exchange rate at RMB1.00 to HK\$1.14.

---

**APPENDIX II                      UNAUDITED PRO FORMA FINANCIAL INFORMATION**

---

**(B) UNAUDITED PRO FORMA FORECAST BASIC EARNINGS PER SHARE**

The following unaudited pro forma forecast basic earnings per Share has been prepared on the basis of the notes set out below for the purpose of illustrating the effect of the Global Offering as if it had taken place on January 1, 2009. This unaudited pro forma forecast basic earnings per Share has been prepared for illustrative purposes only and, because of its nature, it may not give a true picture of the financial results of the Group following the Global Offering or for any future period.

**For the year ending December 31, 2009**

Forecast consolidated profit attributable to owners of the Company <sup>(1)</sup> .....	Not less than RMB101.7 million (equivalent to approximately HK\$115.9 million)
Forecast basic earnings per Share <sup>(2)</sup> .....	Not less than RMB0.14 (equivalent to approximately HK\$0.16)

---

*Notes:*

1. The bases and principal assumptions on which the forecast consolidated profit attributable to owners of the Company for the year ending December 31, 2009 is extracted from the section headed "Profit Forecast" in Appendix III of the prospectus. The bases on which the above profit forecast for the year ending December 31, 2009 has been prepared are summarized in the section headed "Profit Forecast" in Appendix III to the prospectus. In addition, the calculation assumes the translation of Hong Kong dollars to Renminbi with the exchange rate at RMB1.00 to HK\$1.14.
2. The calculation of the forecast basic earnings per Share is based on the forecast consolidated profit attributable to owners of the Company for the year ending December 31, 2009 assuming that the Global Offering had occurred on January 1, 2009 and a total of 702,057,995 Shares had been in issue during the year, but does not take into account any Shares which may be issued upon the exercise of the Over-allotment Option, and assuming the translation of Hong Kong dollars to Renminbi with the exchange rate at RMB1.00 to HK\$1.14.



德勤·關黃陳方會計師行  
香港金鐘道88號  
太古廣場一座35樓

Deloitte Touche Tohmatsu  
35/F One Pacific Place  
88 Queensway  
Hong Kong

### (C) ACCOUNTANTS' REPORTS ON UNAUDITED PRO FORMA FINANCIAL INFORMATION

Set out below is the text of the letter received from our reporting accountants, Deloitte Touche Tohmatsu in respect of the unaudited pro forma financial information for the purpose of incorporation in this prospectus.

#### TO THE DIRECTORS OF MOBI DEVELOPMENT CO., LTD.

We report on the unaudited pro forma financial information of MOBI Development Co., Ltd. (the "Company") and its subsidiaries (hereinafter collectively referred to as the "Group"), which has been prepared by the directors of the Company for illustrative purposes only, to provide information about how the listing of the voting ordinary shares in the Company with a nominal value of US\$0.000001 each on the Main Board of the Stock Exchange ("Listing") might have affected the financial position of the Group after the completion of the Listing, for inclusion in the Appendix II of the prospectus dated December 4, 2009 (the "Prospectus"). The basis of preparation of the unaudited pro forma financial information is set out on Section A of Appendix II to the Prospectus.

#### Respective responsibilities of directors of the Company and reporting accountants

It is the responsibility solely of the directors of the Company to prepare the unaudited pro forma financial information in accordance with paragraph 29 of Chapter 4 of the Rules Governing the Listing of Securities on The Stock Exchange of Hong Kong Limited (the "Listing Rules") and with reference to Accounting Guideline 7 "Preparation of Pro Forma Financial Information for Inclusion in Investment Circulars" issued by the Hong Kong Institute of Certified Public Accountants.

It is our responsibility to form an opinion, as required by paragraph 29(7) of Chapter 4 of the Listing Rules on the unaudited pro forma financial information and to report our opinion to you. We do not accept any responsibility for any reports previously given by us on any financial information used in the compilation of the unaudited pro forma financial information beyond that owed to those to whom those reports were addressed by us at the dates of their issue.

#### Basis of opinion

We conducted our engagement in accordance with Hong Kong Standard on Investment Circular Reporting Engagements 300 "Accountants' Reports on Pro Forma Financial Information in Investment Circulars" issued by the Hong Kong Institute of Certified Public Accountants. Our work consisted primarily of comparing the unadjusted financial information with source documents, considering the evidence supporting the adjustments and discussing the unaudited pro forma financial information with the directors of the Company. This engagement did not involve independent examination of any of the underlying financial information.

We planned and performed our work so as to obtain the information and explanations we considered necessary in order to provide us with sufficient evidence to give reasonable assurance that the unaudited pro forma financial information has been properly compiled by the directors of the Company on the basis stated, that such basis is consistent with the accounting policies of the Group and that the adjustments are appropriate for the purpose of the unaudited pro forma financial information as disclosed pursuant to paragraph 29(1) of Chapter 4 of the Listing Rules.

---

**APPENDIX II                      UNAUDITED PRO FORMA FINANCIAL INFORMATION**

---

The unaudited pro forma financial information is for illustrative purpose only, based on the judgments and assumptions of the directors of the Company, and, because of its hypothetical nature, does not provide any assurance or indication that any event will take place in future and may not be indicative of:

- the financial position of the Group as at August 31, 2009 or any future date; or
- the earnings per share of the Group for the year ending December 31, 2009 or any future period.

**Opinion**

In our opinion:

- a) the unaudited pro forma financial information has been properly compiled by the directors of the Company on the basis stated;
- b) such basis is consistent with the accounting policies of the Group; and
- c) the adjustments are appropriate for the purposes of the unaudited pro forma financial information as disclosed pursuant to paragraph 29(1) of Chapter 4 of the Listing Rules.

**Deloitte Touche Tohmatsu**  
*Certified Public Accountants*  
Hong Kong  
December 4, 2009

The forecast consolidated profit attributable to owners of the Company for the year ending December 31, 2009 is set out in the section headed “Financial Information — Profit Forecast” to this prospectus.

**A. BASES AND ASSUMPTIONS**

The Directors have prepared the forecast of the consolidated profit attributable to the owners for the year ending December 31, 2009, based on the audited consolidated financial statements of the Group for the eight months ended August 31, 2009, the results shown in the unaudited management accounts of the Group for the two months ended October 31, 2009, and a forecast of the results for the remaining two months of the financial year ending December 31, 2009. The profit forecast has been prepared on a basis consistent in all material respects with the accounting policies normally adopted by the Group as summarised in the Accountant’s Report as set out in Appendix I to this prospectus. The profit forecast has been prepared on the following principal bases and assumptions:

- No material changes in existing political, legal, fiscal, market or economic conditions in the PRC, Hong Kong, the Cayman Islands and countries where the Group’s overseas customers and the ultimate customers of the Group’s network solution provider customers operate;
- No material changes in exchange rates, inflation rate and interest rates from those presently prevailing;
- No changes in legislation or regulations governing the wireless telecommunication industry whether in the PRC, Hong Kong, the Cayman Islands and countries where the Group’s overseas customers and the ultimate customers of the Group’s network solution provider customers operate;
- No material changes in the bases or rates or regulation of taxation, both direct and indirect in the PRC, Hong Kong and countries where the Group’s overseas customers and the ultimate customers of the Group’s network solution provider customers operate; and
- No severe interruption on the Group’s operations and business by any force majeure events or unforeseeable factors or any unforeseeable reasons that are beyond the control of the directors, including the occurrence of natural disasters or catastrophes, epidemics or serious accidents.

**B. LETTER FROM THE REPORTING ACCOUNTANTS ON THE PROFIT FORECAST**

The following is the text of a letter received from the reporting accountant, Deloitte Touche Tohmatsu, Certified Public Accountants, Hong Kong, in respect of the forecast of the consolidated profit attributable to owners of the Company for the year ending December 31, 2009, for the purpose of incorporation in this prospectus.

**Deloitte.**  
德勤

德勤·關黃陳方會計師行  
香港金鐘道88號  
太古廣場一座35樓

Deloitte Touche Tohmatsu  
35/F One Pacific Place  
88 Queensway  
Hong Kong

December 4, 2009

The Directors

MOBI Development Co., Ltd.  
Piper Jaffray Asia Limited  
First Shanghai Capital Limited

Dear Sirs,

We have reviewed the accounting policies adopted and calculations made in arriving at the forecast of the consolidated profit of MOBI Development Co., Ltd. (the “Company”) and its subsidiaries (hereinafter collectively referred to as the “Group”) for the year ending December 31, 2009 attributable to owners of the Company (the “Forecast”), for which the directors of the Company are solely responsible, as set out in the prospectus dated December 4, 2009 issued by the Company (the “Prospectus”). The Forecast is prepared based on the audited results of the Group for the eight months ended August 31, 2009, the results shown in the unaudited management accounts of the Group for the two months ended October 31, 2009, and a forecast of the results for the remaining two months of the financial year ending December 31, 2009.

In our opinion the Forecast, so far as the accounting policies and calculations are concerned, has been properly compiled on the basis of the assumptions made by the directors of the Company as set out in Appendix III to the Prospectus and is presented on a basis consistent in all material respects with the accounting policies normally adopted by the Group as set out in our accountants’ report of the financial information on the Group for the three years ended December 31, 2008 and the eight months ended August 31, 2009 as set out in Appendix I to the Prospectus.

Yours faithfully,  
**Deloitte Touche Tohmatsu**  
*Certified Public Accountants*  
Hong Kong

**C. LETTER FROM THE JOINT SPONSORS**

*The following is the text of a letter, prepared for inclusion in this prospectus, we have received from Piper Jaffray Asia Limited and First Shanghai Capital Limited, the Joint Sponsors, in connection with the forecast of the consolidated profit attributable to the owners of the Company for the year ending December 31, 2009.*

Piper Jaffray Asia Limited  
3902B, 39/F., Tower 1  
Lippo Center  
89 Queensway  
Hong Kong

First Shanghai Capital Limited  
19th Floor, Wing On House  
71 Des Voeux Road Central  
Hong Kong

December 4, 2009

The Directors  
MOBI Development Co., Ltd.

Dear Sirs:

We refer to the forecast of the consolidated profit attributable to owners of MOBI Development Co., Ltd. (the “**Company**”) and its subsidiaries (together the “**Group**”) for the year ending December 31, 2009 (the “**Profit Forecast**”) as set out in the prospectus issued by the Company dated December 4, 2009 (the “**Prospectus**”).

We understand that the Profit Forecast, for which the directors of the Company are solely responsible, has been prepared by them based on the audited results of the Group for the eight months ended August 31, 2009, the unaudited management accounts of the Group for the two months ended October 31, 2009 and a forecast of the results of the Group for the remaining two months ending December 31, 2009.

We have discussed with you the bases and assumptions made by the directors of the Company as set out in Appendix III to the Prospectus upon which the Profit Forecast has been made. We have also considered the letter dated December 4, 2009, addressed to yourselves and ourselves from Deloitte Touche Tohmatsu regarding the accounting policies and calculations upon which the Profit Forecast has been made.

On the basis of the information comprising the Profit Forecast and on the basis of the accounting policies and calculations adopted by you and reviewed by Deloitte Touche Tohmatsu, we are of the opinion that the Profit Forecast, for which you as directors of the Company are solely responsible, has been made after due and careful enquiry.

Yours faithfully,

For and on behalf of  
**Piper Jaffray Asia Limited**  
**Stacey Wong**  
*Head of Investment Banking*

For and on behalf of  
**First Shanghai Capital Limited**  
**Eric Lee**  
*Deputy Managing Director*

The following is the text of a letter, summary of values and valuation certificate, prepared for the purpose of incorporation in this prospectus and received from Savills Valuation and Professional Services Limited, an independent property valuer, in connection with their valuations as at 30 September 2009 of the property interests of the Group.



Savills Valuation and  
Professional Services Limited  
23/F Two Exchange Square  
Central, Hong Kong

T : (852) 2801 6100  
F : (852) 2530 0756

EA Licence: C-023750  
savills.com

4 December 2009

The Directors  
MOBI Development Co., Ltd.  
7 Langshan First Road  
Science and Technology Park  
Nanshan District  
Shenzhen  
Guangdong Province  
The People's Republic of China

Dear Sirs,

In accordance with your instructions for us to value the properties held by MOBI Development Co., Ltd. (hereinafter referred to as the “**Company**”) and its subsidiaries (together referred to as the “**Group**”) in the People's Republic of China (the “**PRC**”), we confirm that we have carried out inspections, made relevant enquiries and obtained such further information as we consider necessary for the purpose of providing you with our opinion of values of the properties as at 30 September 2009 (the “Date of Valuation”) for the purpose of incorporation in an Initial Public Offering Document.

Our valuation of each of the properties is our opinion of its market value which we would define as intended to mean “the estimated amount for which a property should exchange on the date of valuation between a willing buyer and a willing seller in an arm's-length transaction after proper marketing wherein the parties had each acted knowledgeably, prudently and without compulsion”.

The market value is the best price reasonably obtainable in the market by the seller and the most advantageous price reasonably obtainable in the market by the buyer. This estimate specifically excludes an estimated price inflated or deflated by special terms or circumstances such as atypical financing, sale and leaseback arrangements, special considerations or concessions granted by anyone associated with the sale, or any element of special value. The market value of a property is also estimated without regard to costs of sale and purchase, and without offset for any associated taxes.

The property interests in Group I are held and occupied by the Group in the PRC. Due to the specific purposes for which the buildings and structures of the properties in Group I have been constructed, there are no readily identifiable market comparables. Thus the buildings and structures cannot be valued on the basis of direct comparison approach. They have therefore been valued on the basis of their depreciated replacement costs. We would define “depreciated replacement cost” for this purpose to be our opinion of the land value in its existing use and an estimate of the new replacement costs of the buildings and structures, including professional fees and finance charges, from which deductions are then made to allow for age, condition and functional obsolescence. The depreciated replacement cost approach generally provides the most reliable indication of value for property in the absence of a known market based on comparable sales.

For the property interests in Group II, which are leased and occupied by the Group in the PRC, we have attributed no commercial value to such properties due to the prohibition against assignment or subletting or otherwise lack of substantial profit rent.

We have been provided with copies of extracts of the title documents relating to the properties in the PRC such as building ownership certificate, state-owned land use certificate and relevant planning permits. However, we have not inspected the original documents to verify ownership or to verify any amendments which may not appear on the copies handed to us. We have relied to a considerable extent on the information given by the Group and its PRC legal adviser, Zhong Lun Law Firm, regarding the titles and other legal matters relating to the properties. We have also accepted advice given by the Group on such matters as planning approvals or statutory notices, easements, tenures, ownership, completion dates, particulars of occupancy, site and floor areas and all other relevant matters. Dimensions, measurements and areas included in the valuation certificate are based on information contained in the documents provided to us and are therefore only approximations. No on-site measurements have been taken. We have no reason to doubt the truth and accuracy of the information provided to us by the Group which is material to the valuation. We were also advised by the Group that no material facts have been omitted from the information provided.

We have inspected the exterior and, where possible, the interior of the properties. During the course of our inspection, we did not note any serious defects. However, no structural survey has been made, we are therefore unable to report whether the properties are free from rot, infestation or any other structural defects. No tests were carried out on any of the services.

No allowance has been made in our valuation for any charges, mortgages or amounts owing on any property nor for any expenses or taxation which may be incurred in effecting a sale. Unless otherwise stated, it is assumed that all the properties are free from encumbrances, restrictions and outgoings of an onerous nature which could affect their values.

In valuing the properties, we have complied with all requirements set out in Chapter 5 and Practice Note 12 of the Rules Governing the Listing of Securities issued by The Stock Exchange of Hong Kong Limited and The Valuation Standards on Properties (First Edition January 2005) published by The Hong Kong Institute of Surveyors.

Unless otherwise stated, all money amounts are stated in Renminbi (“RMB”).

Our summary of values and valuation certificate are attached herewith.

Yours faithfully,  
For and on behalf of  
**Savills Valuation and Professional Services Limited**  
**Charles C K Chan**  
*MSc FRICS FHKIS MCI Arb RPS(GP)*  
Managing Director

*Note: Charles C K Chan, Chartered Estate Surveyor, MSc, FRICS, FHKIS, MCI Arb, RPS(GP), has been a qualified valuer and has about 25 years' experience in the valuation of properties in Hong Kong and has about 20 years' experience in the valuation of properties in the PRC.*

## SUMMARY OF VALUES

Property	Capital value in existing state as at 30 September 2009 <i>RMB</i>
<b>Group I — Property interests held and occupied by the Group in the PRC</b>	
1. MOBI Building, 7 Langshan First Road, Science and Technology Park, Nanshan District, Shenzhen, Guangdong Province, The PRC	No commercial value
2. An industrial complex located at Jizhou Industrial Park, Jizhou District, Ji'an, Jiangxi Province, The PRC	RMB12,400,000
3. An industrial complex located at 6 Shuoshi Road, New Type Industrial Park, Xi'an, Shaanxi Province, The PRC	RMB28,400,000
<b>Sub-total:</b>	<hr/> RMB40,800,000
<b>Group II — Property interests leased and occupied by the Group in the PRC</b>	
4. No. 15 Factory Building, Xili Chaguang Industrial Park, Shahe Road West, Nanshan District, Shenzhen, Guangdong Province, The PRC	No commercial value
5. Levels 2 to 4 of Block 7, Xili Chaguang Industrial Park, Shahe Road West, Nanshan District, Shenzhen, Guangdong Province The PRC	No commercial value

<b>Property</b>	<b>Capital value in existing state as at 30 September 2009 RMB</b>
6. 14 units of Block 7, Chaguang Industrial Park, Nanshan District, Shenzhen, Guangdong Province, The PRC	No commercial value
7. 81 units of Block B, De Li Yuan, Ke Yuan North Road, Songpingshan Industrial Park, Nanshan District, Shenzhen, Guangdong Province, The PRC	No commercial value
8. 17 units of Block 2, Taoyuan Pingshan Minqi Industrial Park, Lishui Road, Nanshan District, Shenzhen, Guangdong Province, The PRC	No commercial value
9. Levels 1 and 2 of Block 3, Taoyuan Pingshan Minqi Industrial Park, Lishui Road, Nanshan District, Shenzhen, Guangdong Province, The PRC	No commercial value
10. 50 units of Block 7, Xili Wenguang Village, Nanshan District, Shenzhen, Guangdong Province, The PRC	No commercial value

<b>Property</b>	<b>Capital value in existing state as at 30 September 2009 RMB</b>
11. 70 units of Block 1, Runheng Electronics Factory, Liu Xian Er Road, Xin'an Street, Bao'an District, Shenzhen, Guangdong Province, The PRC	No commercial value
12. Blocks 2 and 3, Runheng Electronics Factory, Liu Xian Er Road, Xin'an Street, Bao'an District, Shenzhen, Guangdong Province, The PRC	No commercial value
13. Block 1, Zhongxin Industrial Park, Ji'an, Jiangxi Province, The PRC	No commercial value
14. Blocks 5 and 7, Jizhou Industrial Park, Ji'an, Jiangxi Province, The PRC	No commercial value
<b>Sub-total:</b>	<u>Nil</u>
<b>Total:</b>	<u><u>RMB40,800,000</u></u>

## VALUATION CERTIFICATE

## Group I — Property interests held and occupied by the Group in the PRC

No.	Property	Description and tenure	Particulars of occupancy	Capital value in existing state as at 30 September 2009
1.	MOBI Building, 7 Langshan First Road, Science and Technology Park, Nanshan District, Shenzhen, Guangdong Province, The PRC	<p>The property comprises an 8-storey industrial building (plus a level of basement) erected on a parcel of land with a site area of approximately 5,833.46 sq.m. (62,791 sq.ft.). The building was completed in 2007.</p> <p>The total gross floor area of the property is approximately 16,411.98 sq.m. (176,659 sq.ft.).</p> <p>The land use rights of the property have been granted for a term of 50 years commencing on 20 June 2000 and expiring on 19 June 2050 for industrial use.</p>	The property is occupied by the Group for production use.	No commercial value (Note 4)

*Notes:*

- (1) Pursuant to a Real Estate Title Certificate — Shen Fang Di Zi No. 4000189497, the land use rights of the property with a site area of approximately 5,833.46 sq.m. have been granted to MOBI Antenna Technologies (Shenzhen) Co., Ltd. (“MOBI Shenzhen”) for a term of 50 years commencing on 20 June 2000 and expiring on 19 June 2050 for industrial use.
- (2) Pursuant to a Real Estate Title Certificate — Shen Fang Di Zi No. 4000338515, the building ownership of the property with a gross floor area of approximately 16,411.98 sq.m. is held by MOBI Shenzhen.
- (3) We have been provided with a legal opinion on the title to the property issued by the Group’s legal adviser, which contains, inter-alia, the following information:
  - i. the property is legally held by MOBI Shenzhen. MOBI Shenzhen is entitled to use or occupy the property and has the rights to mortgage the property after obtaining consents from the relevant government authorities;
  - ii. the transfer and lease of the property are prohibited;
  - iii. the land premium of the property has been settled in full; and
  - iv. the property is free from any mortgages and third party encumbrances.
- (4) We have ascribed no commercial value to the property as the property is not allowed to be transferred. However, as per the Group’s instruction and for reference purposes, we are of the opinion that the estimated capital value of the property as of the Date of Valuation would be RMB98,500,000 by assuming that the property is freely transferable in the market and that all relevant approvals have been obtained from the government authorities and all extra land premium and other related expenses have been settled in full.

No.	Property	Description and tenure	Particulars of occupancy	Capital value in existing state as at 30 September 2009
2.	An industrial complex located at Jizhou Industrial Park, Jizhou District, Ji'an, Jiangxi Province, The PRC	<p>The property comprises an industrial complex erected on a parcel of land with a site area of approximately 41,140.00 sq.m. (442,831 sq.ft.).</p> <p>The industrial complex comprises a 5-storey dormitory and a 2-storey canteen (partially erected on the aforesaid land) completed in 2009.</p> <p>The total gross floor area of the property is approximately 8,943.60 sq.m. (96,269 sq.ft.).</p> <p>The land use rights of the property have been granted for a term expiring on 25 July 2056 for industrial use.</p>	The property is occupied by the Group for production use.	RMB12,400,000 (Note 5)

*Notes:*

- (1) Pursuant to a State-owned Land Use Certificate — Ji Zhou Guo Yong (2006) No. 1-901, the land uses rights of the property with a site area of approximately 41,140.00 sq.m. have been granted to MOBI Telecommunication Technologies (Jian) Co., Ltd. (“MOBI Jian”) for a term expiring on 25 July 2056 for industrial use.
- (2) Pursuant to a Building Ownership Certificate — Ji Fang Quan Zheng Ji Zhou Zi No. 00130180, the building ownership of portion of the property (the 5-storey dormitory) with a gross floor area of approximately 5,811.86 sq.m. is held by MOBI Jian.
- (3) Pursuant to a Building Ownership Certificate — Ji Fang Quan Zheng Ji Zhou Zi No. 00130179, the building ownership of the remaining portion of the property (the 2-storey canteen) with a gross floor area of approximately 3,131.74 sq.m. is held by MOBI Jian and Shenzhen Zhongxin Weixiantong Shebei Co., Ltd. (深圳市中興維先通設備有限公司) (“Shenzhen Weixiantong”).
- (4) We have been provided with a legal opinion on the title to the property issued by the Group’s legal adviser, which contains, inter-alia, the following information:
  - i. portion of the property with a gross floor area of approximately 5,811.86 sq.m. is legally held by MOBI Jian. MOBI Jian is entitled to transfer, mortgage, lease or dispose of such portion of the property;
  - ii. the remaining portion of the property with a gross floor area of approximately 3,131.74 sq.m. is legally held by MOBI Jian and Shenzhen Weixiantong (Joint-owners). MOBI Jian is entitled to transfer, mortgage, lease or dispose of such portion of the property after obtaining consents from Weixiantong;
  - iii. the land premium of the property has been settled in full; and
  - iv. except for the above, the property is free from any other mortgages and third party encumbrances.
- (5) In the course of our valuation, we have assumed that the Group is entitled to transfer, mortgage, lease or dispose of the whole or any part of the property.

No.	Property	Description and tenure	Particulars of occupancy	Capital value in existing state as at 30 September 2009
3	An industrial complex located at 6 Shuoshi Road, New Type Industrial Park, Xi'an, Shaanxi Province, The PRC	<p>The property comprises an industrial complex on a parcel of land with a site area of approximately 27,955.30 sq.m. (300,911 sq.ft.).</p> <p>The industrial complex comprises a 2-storey industrial building, a 3-storey industrial building, a 4-storey research centre, a pump room and a boiler room completed in 2004.</p> <p>The total gross floor area of the property is approximately 10,829.31 sq.m. (116,567 sq.ft.).</p> <p>The land use rights of the property have been granted for a term expiring on 12 March 2058 for industrial use.</p>	The property is occupied by the Group for production use.	RMB28,400,000

*Notes:*

- (1) Pursuant to a State-owned Land Use Certificate — Xi Gao Ke Ji Guo Yong (2009) No. 37527, the land use rights of the property with a site area of approximately 27,955.30 sq.m. have been granted to MOBI Antenna Technologies (Xi'an) Co., Ltd. ("MOBI Xi'an") for a term expiring on 12 March 2058 for industrial use.
- (2) Pursuant to a Building Ownership Certificate — Xi An Shi Fang Quan Zheng Gao Xin Qu Zi No. 1025098019-7-1, the building ownership of the property with a total gross floor area of approximately 10,829.31 sq.m. is held by MOBI Xi'an.
- (3) We have been provided with a legal opinion on the title to the property issued by the Group's legal adviser, which contains, inter-alia, the following information:
  - i. the property is legally held by MOBI Xi'an, MOBI Xi'an is entitled to transfer, mortgage, lease or dispose of the property;
  - ii. the land premium of the property has been settled in full; and
  - iii. the property is free from any mortgages and third party encumbrances.

## Group II — Property interests leased and occupied by the Group in the PRC

No.	Property	Description and tenancy particulars	Particulars of occupancy	Capital value in existing state as at 30 September 2009
4.	No. 15 Factory Building, Xili Chaguang Industrial Park, Shahe Road West, Nanshan District, Shenzhen, Guangdong Province, The PRC	<p>The property comprises a 5-storey factory building with a gross floor area of approximately 11,160.00 sq.m. (120,126 sq.ft.) completed in 1997.</p> <p>The property is rented by the Group from an independent third party for a term of three years commencing on 1 December 2006 and expiring on 30 November 2009 at a monthly rental of RMB161,820.</p>	The property is occupied by the Group for production use.	No commercial value

*Notes:*

1. Pursuant to a tenancy agreement entered into between Shenzhen Baodazhou Industry Development Co., Ltd. (深圳市寶大洲實業發展有限公司) (the “Lessor”), an independent third party, and MOBI Antenna Technologies (Shenzhen) Co., Ltd. (“MOBI Shenzhen”) on 30 March 2007, the property with a gross floor area of approximately 11,160.00 sq.m. has been leased to MOBI Shenzhen for a term of three years commencing on 1 December 2006 expiring on 30 November 2009 at a monthly rental of RMB161,820.
2. We have been provided with a legal opinion on the title to the property issued by the Group’s legal adviser, which contains, inter alia, the following information:
  - i. the Lessor has not provided us with the Building Ownership Certificates or relevant title documents of the property for verification;
  - ii. the Lessor has not provided us with the Construction Works Planning Permits of the property for verification, the tenancy agreement may be invalid and the rights of MOBI Shenzhen under the tenancy agreement may not be recognized and protected under the PRC laws; and
  - iii. the tenancy agreement has been registered.

No.	Property	Description and tenancy particulars	Particulars of occupancy	Capital value in existing state as at 30 September 2009
5.	Levels 2 to 4 of Block 7, Xili Chaguang Industrial Park, Shahe Road West, Nanshan District, Shenzhen, Guangdong Province, The PRC	<p>The property comprises the whole of Levels 2 to 4 of a 7-storey residential building with a total gross floor area of approximately 672.00 sq.m. (7,233 sq.ft.) completed in 1997.</p> <p>The property is rented by the Group from an independent third party for a term of three years commencing on 1 December 2006 and expiring on 30 November 2009 at a monthly rental of approximately RMB19,740 exclusive of management fee.</p>	The property is occupied by the Group for residential use.	No commercial value

*Notes:*

1. Pursuant to a tenancy agreement entered between Shenzhen Baodazhou Industry Development Co., Ltd. (深圳市寶大洲實業發展有限公司) (the "Lessor"), an independent third party, and MOBI Antenna Technologies (Shenzhen) Co., Ltd. ("MOBI Shenzhen") on 1 December 2006, the property has been leased to MOBI Shenzhen for a term of three years commencing on 1 December 2006 and expiring on 30 November 2009 at a monthly rental of RMB19,740 exclusive of management fee.
2. We have been provided with a legal opinion on the title to the property issued by the Group's legal adviser, which contains, inter alia, the following information:
  - i. the Lessor has not provided us with the Building Ownership Certificates and the relevant title documents of the property for verification, the Lessor may not be entitled to lease the property to MOBI Shenzhen;
  - ii. the Lessor has not provided us with the Construction Works Planning Permits of the property for verification, the tenancy agreement may be invalid and the rights of MOBI Shenzhen under the tenancy agreement may not be recognized and protected under the PRC laws; and
  - iii. the tenancy agreement has not been registered. According to the PRC laws, MOBI Shenzhen may be subject to a fine of 10% of total rental amount in the event of MOBI Shenzhen's fault in causing the non-registration of the tenancy agreement.

No.	Property	Description and tenancy particulars	Particulars of occupancy	Capital value in existing state as at 30 September 2009
6.	14 units of Block 7, Chaguang Industrial Park, Nanshan District, Shenzhen, Guangdong Province, The PRC	<p>The property comprises 14 residential units on Level 5 of a 7-storey residential building with a total gross floor area of approximately 224.00 sq.m. (2,411 sq.ft.) completed in 1997.</p> <p>The property is rented by the Group from an independent third party for a term commencing on 1 March 2009 and expiring on 30 November 2009 at a monthly rental of approximately RMB8,000 exclusive of management fee.</p>	The property is occupied by the Group for residential use.	No commercial value

*Notes:*

1. Pursuant to a tenancy agreement entered into between Shenzhen Baodazhou Industry Development Co., Ltd. (深圳市寶大洲實業發展有限公司) (the "Lessor"), an independent third party, and MOBI Antenna Technologies (Shenzhen) Co., Ltd. ("MOBI Shenzhen") on 23 February 2009, the property has been leased to MOBI Shenzhen for a term commencing on 1 March 2009 and expiring on 30 November 2009 at a monthly rental of RMB8,000 exclusive of management fee.
2. We have been provided with a legal opinion on the title to the property issued by the Group's legal adviser, which contains, inter alia, the following information:
  - i. the Lessor has not provided us with the Building Ownership Certificates and the relevant title documents of the property for verification, the Lessor may not be entitled to lease the property to MOBI Shenzhen;
  - ii. the Lessor has not provided us with the Construction Works Planning Permits of the property for verification, the tenancy agreement may be invalid and the rights of MOBI Shenzhen under the tenancy agreement may not be recognized and protected under the PRC laws; and
  - iii. the tenancy agreement has not been registered. According to the PRC laws, MOBI Shenzhen may be subject to a fine of 10% of total rental amount in the event of MOBI Shenzhen's fault in causing the non-registration of the tenancy agreement.

No.	Property	Description and tenancy particulars	Particulars of occupancy	Capital value in existing state as at 30 September 2009
7.	81 units of Block B, De Li Yuan, Ke Yuan North Road, Songpingshan Industrial Park, Nanshan District, Shenzhen, Guangdong Province, The PRC	<p>The property comprises 81 residential units on Levels 2 to 4 of a 4-storey residential building with a total gross floor area of approximately 1,620.00 sq.m. (17,438 sq.ft.) completed in 2003.</p> <p>The property is rented by the Group from an independent third party for a term of two years commencing on 10 March 2008 and expiring on 31 March 2010 at a monthly rental of approximately RMB60,750 exclusive of management fee.</p>	The property is occupied by the Group for residential use.	No commercial value

*Notes:*

1. Pursuant to a tenancy agreement entered into between Shenzhen Runlida Investment Development Co., Ltd., Songpingshan Branch (深圳市潤利達投資開發有限公司松坪山分公司) (the "Lessor"), an independent third party, and MOBI Antenna Technologies (Shenzhen) Co., Ltd. ("MOBI Shenzhen") on 8 March 2008, the property has been leased to MOBI Shenzhen for a term of two years commencing on 10 March 2008 and expiring on 31 March 2010 at a monthly rental of RMB60,750 exclusive of management fee.
2. We have been provided with a legal opinion on the title to the property issued by the Group's legal adviser, which contains, inter alia, the following information:
  - i. the Lessor has not provided us with the Building Ownership Certificates and the relevant title documents of the property for verification, the Lessor may not be entitled to lease the property to MOBI Shenzhen;
  - ii. the Lessor has not provided us with the Construction Works Planning Permits of the property for verification, the tenancy agreement may be invalid and the rights of MOBI Shenzhen under the tenancy agreement may not be recognized and protected under the PRC laws; and
  - iii. the tenancy agreement has not been registered. According to the PRC laws, MOBI Shenzhen may be subject to a fine of 10% of total rental amount in the event of MOBI Shenzhen's fault in causing the non-registration of the tenancy agreement.

No.	Property	Description and tenancy particulars	Particulars of occupancy	Capital value in existing state as at 30 September 2009
8.	17 units of Block 2, Taoyuan Pingshan Minqi Industrial Park, Lishui Road, Nanshan District, Shenzhen, Guangdong Province, The PRC	<p>The property comprises 17 residential units on Levels 1, 2 and 4 of a 7-storey dormitory with a total gross floor area of approximately 340.00 sq.m. (3,660 sq.ft.) completed in 1998.</p> <p>The property is rented by the Group from an independent third party for a term of two years commencing on 1 March 2009 and expiring on 30 April 2011 at a monthly rental of approximately RMB11,900 exclusive of management fee.</p>	The property is occupied by the Group for residential use.	No commercial value

*Notes:*

1. Pursuant to a tenancy agreement entered into between Shenzhen Pingshan Industry Co., Ltd. (深圳市平山實業股份有限公司) (the "Lessor"), an independent third party, and MOBI Antenna Technologies (Shenzhen) Co., Ltd. ("MOBI Shenzhen") on 25 March 2009, the property has been leased to MOBI Shenzhen for a term of two years commencing on 1 March 2009 and expiring on 30 April 2011 at a monthly rental of RMB11,900 exclusive of management fee.
2. We have been provided with a legal opinion on the title to the property issued by the Group's legal adviser, which contains, inter alia, the following information:
  - i. the Lessor has not provided us with the Building Ownership Certificates and the relevant title documents of the property for verification, the Lessor may not be entitled to lease the property to MOBI Shenzhen;
  - ii. the Lessor has not provided us with the Construction Works Planning Permits of the property for verification, the tenancy agreement may be invalid and the rights of MOBI Shenzhen under the tenancy agreement may not be recognized and protected under the PRC laws; and
  - iii. the tenancy agreement has not been registered. According to the PRC laws, MOBI Shenzhen may be subject to a fine of 10% of total rental amount in the event of MOBI Shenzhen's fault in causing the non-registration of the tenancy agreement.

No.	Property	Description and tenancy particulars	Particulars of occupancy	Capital value in existing state as at 30 September 2009
9.	Levels 1 and 2 of Block 3, Taoyuan Pingshan Minqi Industrial Park, Lishui Road, Nanshan District, Shenzhen, Guangdong Province, The PRC	<p>The property comprises Level 1 and Level 2 of a 6-storey factory building with a total gross floor area of approximately 3,810.00 sq.m. (41,011 sq.ft.) completed in 1998.</p> <p>The property is rented by the Group from an independent third party for a term commencing on 10 July 2008 and expiring on 30 April 2011 at a monthly rental of approximately RMB102,870.</p>	The property is occupied by the Group for production use.	No commercial value

*Notes:*

1. Pursuant to a tenancy agreement entered into between Shenzhen Pingshan Industry Co., Ltd. (深圳市平山實業股份有限公司) (the "Lessor"), an independent third party, and MOBI Antenna Technologies (Shenzhen) Co., Ltd. ("MOBI Shenzhen") on 15 July 2008, the property with a gross floor area of approximately 3,810.00 sq.m. has been leased to MOBI Shenzhen for a term commencing on 10 July 2008 and expiring on 30 April 2011 at a monthly rental of RMB102,870.
2. We have been provided with a legal opinion on the title to the property issued by the Group's legal adviser, which contains, inter alia, the following information:
  - i. the Lessor has not provided us with the Building Ownership Certificates or relevant title documents of the property for verification;
  - ii. the Lessor has not provided us with the Construction works Planning Permits of the property for verification, the tenancy agreement may be invalid and the rights of MOBI Shenzhen under the tenancy agreement may not be recognized and protected under the PRC laws; and
  - iii. the tenancy agreement has been registered.

No.	Property	Description and tenancy particulars	Particulars of occupancy	Capital value in existing state as at 30 September 2009
10.	50 units of Block 7, Xili Wenguang Village, Nanshan District, Shenzhen, Guangdong Province, The PRC	<p>The property comprises 50 residential units of a 7-storey dormitory with a total gross floor of approximately 900.00 sq.m. (9.688 sq.ft.) completed in 1997.</p> <p>The property is rented by the Group from an independent third party for a term of one year commencing on 1 September 2009 and expiring on 31 August 2010 at a monthly rental of approximately RMB32,500.</p>	The property is occupied by the Group for dormitory use.	No commercial value

*Notes:*

1. Pursuant to a tenancy agreement entered between Liu Shao Hua (劉紹華) (the “Lessor”), an independent third party, and MOBI Antenna Technologies (Shenzhen) Co., Ltd. (“MOBI Shenzhen”) on 28 September 2009, the property has been leased to MOBI Shenzhen for a term of one year commencing on 1 September 2009 and expiring on 31 August 2010 at a monthly rental of RMB32,500.
2. We have been provided with a legal opinion on the title to the property issued by the Group’s legal adviser, which contains, inter alia, the following information:
  - i. the Lessor has not provided us with the Building Ownership Certificate and the relevant title documents of the property for verifications, the Lessor may not be entitled to lease the property to MOBI Shenzhen;
  - ii. the Lessor has not provided us with the Construction Works Planning Permits of the property for verification, the tenancy agreement may be invalid and the rights of MOBI Shenzhen under the tenancy agreement may not be recognized and protected under the PRC laws; and
  - iii. the tenancy agreement has not been registered. According to the PRC laws, MOBI Shenzhen may be subject to a fine of 10% of total rental amount in the event of MOBI Shenzhen’s fault in causing the non-registration of the tenancy agreement.

No.	Property	Description and tenancy particulars	Particulars of occupancy	Capital value in existing state as at 30 September 2009
11	70 units of Block 1, Runheng Electronics Factory, Liu Xiao Er Road, Xin'an Street, Bao'an District, Shenzhen, Guangdong Province, The PRC	<p>The property comprises 70 units of a 5-storey residential building with a total gross floor area of approximately 2,940.00 sq.m. (31,646 sq.ft.) completed in 2009.</p> <p>The property is rented by the Group from an independent third party for a term of five years commencing on 25 September 2009 and the rent-free period is from 25 September 2009 to 24 November 2009. The total monthly rentals for the first 3 years and the remaining 2 years are RMB73,500 and RMB84,490 respectively.</p>	The property is occupied by the Group for dormitory use.	No commercial value

*Notes:*

1. Pursuant to a tenancy agreement entered into between Shenzhen Runheng Real Estate Development Group Co., Ltd. (深圳潤恒房地產開發集團有限公司) (the "Lessor"), an independent third party, and MOBI Antenna Technologies (Shenzhen) Co., Ltd. ("MOBI Shenzhen") on 11 September 2009, the property with a gross floor area of approximately 2,940.00 sq.m. has been leased to MOBI Shenzhen for a term of five years commencing on 25 September 2009 and the rent-free period is from 25 September 2009 to 24 November 2009. The total monthly rentals for the first 3 years and the remaining 2 years are RMB73,500 and RMB84,490 respectively.
2. We have been provided with a legal opinion on the title to the property issued by the Group's legal adviser, which contains, inter alia, the following information:
  - i. the Lessor has obtained the State-owned Land Use Certificate and the Construction Works Planning Permit of the property and is in the process of obtaining the Real Estate Title Certificates of the property. The Lessor has the rights to lease the property to MOBI Shenzhen;
  - ii. the tenancy agreement is legal, valid and binding on both parties under the PRC laws; and
  - iii. the tenancy agreement has been registered.

No.	Property	Description and tenancy particulars	Particulars of occupancy	Capital value in existing state as at 30 September 2009
12	Blocks 2 and 3, Runheng Electronics Factory, Liu Xiao Er Road, Xin'an Street, Bao'an District, Shenzhen, Guangdong Province, The PRC	<p>The property comprises two 5-storey factory buildings with a total gross floor area of approximately 23,900.00 sq.m. (257,260 sq.ft.) completed in 2009.</p> <p>The property is rented by the Group from an independent third party for a term of five years commencing on 25 September 2009 and the rent-free period is from 25 September 2009 to 24 November 2009. The total monthly rentals for the first 3 years and the remaining 2 years are RMB422,150 and RMB509,070 respectively.</p>	The property is occupied by the Group for production use.	No commercial value

*Notes:*

1. Pursuant to a tenancy agreement entered into between Shenzhen Runheng Real Estate Development Group Co., Ltd. (深圳潤恒房地產開發集團有限公司) (the "Lessor"), an independent third party, and MOBI Antenna Technologies (Shenzhen) Co., Ltd. ("MOBI Shenzhen") on 11 September 2009, the property with a gross floor area of approximately 23,900.00 sq.m. has been leased to MOBI Shenzhen for a term of five years commencing on 25 September 2009 and the rent-free period is from 25 September 2009 to 24 November 2009. The total monthly rentals for the first 3 years and the remaining 2 years are RMB442,150 and RMB509,070 respectively.
2. We have been provided with a legal opinion on the title to the property issued by the Group's legal adviser, which contains, inter alia, the following information:
  - i. the Lessor has obtained the State-owned Land Use Certificate and the Construction Works Planning Permit of the property and is in the process of obtaining the Real Estate Title Certificates of the property. The Lessor has the rights to lease the property to MOBI Shenzhen;
  - ii. the tenancy agreement is legal, valid and binding on both parties under the PRC laws; and
  - iii. the tenancy agreement has been registered.

No.	Property	Description and tenancy particulars	Particulars of occupancy	Capital value in existing state as at 30 September 2009
13.	Block 1, Zhongxin Industrial Park, Ji'an, Jiangxi Province, The PRC	<p>The property comprises a 2-storey industrial building with a gross floor area of approximately 12,111.70 sq.m. (130,370 sq.ft.) completed in 2008.</p> <p>The property is rented by the Group from an independent third party for a term of two years commencing on 1 March 2009 and expiring on 28 February 2011 at a monthly rental of RMB 72,670.20 for the first year and RMB 78,726.05 for the second year.</p>	The property is occupied by the Group for production use.	No commercial value

*Notes:*

1. Pursuant to a tenancy agreement entered into between Jian Zhongxing Weixiantong Shebei Co., Ltd. (吉安中興維先通設備有限公司) (the "Lessor"), an independent third party, and MOBI Telecommunication Technologies (Jian) Co., Ltd. ("MOBI Jian") on 27 February 2009, the property with a gross floor area of approximately 12,111.70 sq.m. has been leased to MOBI Jian for a term of two years commencing on 1 March 2009 and expiring on 28 February 2010 at a monthly rental of RMB72,670.20 for the first year and RMB78,726.05 for the second year.
2. We have been provided with a legal opinion on the title to the property issued by the Group's legal adviser, which contains, inter alia, the following information:
  - i. Shenzhen Zhongxing Weixiantong Shebei Co., Ltd. (深圳市中興維先通設備有限公司) (the "Owner") has obtained the Building Ownership Certificates of the property. The Lessor has obtained the authorization from the Owner and has the rights to lease the property to MOBI Jian;
  - ii. the tenancy agreement is legal, valid and binding on both parties under the PRC laws; and
  - iii. the tenancy agreement has been registered.

No.	Property	Description and tenancy particulars	Particulars of occupancy	Capital value in existing state as at 30 September 2009
14.	Blocks 5 to 7, Jizhou Industrial Park, Ji'an, Jiangxi Province, The PRC	<p>The property comprises three single-storey industrial buildings with a total gross floor area of approximately 5,294.30 sq.m. (56,988 sq.ft.) completed in 2005.</p> <p>The property is rented by the Group from an independent third party for a term of one year commencing on 1 May 2009 and expiring on 30 April 2010 at a monthly rental of approximately RMB31,756.80.</p>	The property is occupied by the Group for production use.	No commercial value

*Notes:*

1. Pursuant to a tenancy agreement entered into between Jiangxi Province Biliqi Motors Co., Ltd. (江西省比力奇車業有限公司) (the "Lessor"), an independent third party, and MOBI Telecommunication Technologies (Jian) Co., Ltd. ("MOBI Jian") on 20 April 2009, the property with a total gross floor area of approximately 5,294.30 sq.m. has been leased to MOBI Jian for a term of one year commencing on 1 May 2009 and expiring on 30 April 2010 at a monthly rental of RMB31,765.80.
2. We have been provided with a legal opinion on the title to the property issued by the Group's legal adviser, which contains, inter alia, the following information:
  - i. the Lessor has obtained the Building Ownership Certificates of the property and has the rights to lease the property to MOBI Jian.
  - ii. the tenancy agreement is legal, valid and binding on both parties under the PRC laws; and
  - iii. the tenancy agreement has been registered.

**1 MEMORANDUM OF ASSOCIATION**

The Memorandum of Association of the Company was adopted on November 25, 2009 and states, inter alia, that the liability of members of the Company is limited, that the objects for which the Company is established are unrestricted and the Company shall have full power and authority to carry out any object not prohibited by the Companies Law or any other law of the Cayman Islands.

The Memorandum of Association is available for inspection at the address specified in Appendix VII in the section headed “Documents available for inspection”.

**2 ARTICLES OF ASSOCIATION**

The Articles of Association of the Company were adopted on November 25, 2009 and include provisions to the following effect:

**2.1 Classes of Shares**

The share capital of the Company consists of ordinary shares. The capital of the Company at the date of adoption of the Articles of Association is US\$2,000 divided into 2,000,000,000 shares of US\$0.000001 each.

**2.2 Directors***2.2.1 Power to allot and issue Shares*

Subject to the provisions of the Companies Law and the Memorandum and Articles of Association, the unissued shares in the Company (whether forming part of its original or any increased capital) shall be at the disposal of the Directors, who may offer, allot, grant options over or otherwise dispose of them to such persons, at such times and for such consideration, and upon such terms, as the Directors shall determine.

Subject to the provisions of the Articles of Association and to any direction that may be given by the Company in general meeting and without prejudice to any special rights conferred on the holders of any existing shares or attaching to any class of shares, any share may be issued with or have attached thereto such preferred, deferred, qualified or other special rights or restrictions, whether in regard to dividend, voting, return of capital or otherwise, and to such persons at such time and for such consideration as the Directors may determine. Subject to the Companies Law and to any special rights conferred on any shareholders or attaching to any class of shares, shares may as the Board may deem fit, be issued on terms that they are or at the option of the Company or the holder thereof, liable to be redeemed.

*2.2.2 Power to dispose of the assets of the Company or any subsidiary*

The management of the business of the Company shall be vested in the Directors who, in addition to the powers and authorities by the Articles of Association expressly conferred upon them, may exercise all such powers and do all such acts and things as may be exercised or done or approved by the Company and are not by the Articles of Association or the Companies Law expressly directed or required to be exercised or done by the Company in general meeting, but subject nevertheless to the provisions of the Companies Law and of the Articles of Association and to any regulation from time to time made by the Company in general meeting not being inconsistent with such provisions or the Articles of Association, provided that no regulation so made shall invalidate any prior act of the Directors which would have been valid if such regulation had not been made.

*2.2.3 Compensation or payment for loss of office*

Payment to any Director or past Director of any sum by way of compensation for loss of office or as consideration for or in connection with his retirement from office (not being a payment to which the Director is contractually entitled) must first be approved by the Company in general meeting.

*2.2.4 Loans to Directors*

There are provisions in the Articles of Association prohibiting the making of loans to Directors and associates which are equivalent to the restrictions imposed by the Companies Ordinance.

*2.2.5 Financial assistance to purchase Shares*

Subject to all applicable laws, the Company may give financial assistance to Directors and employees of the Company, its subsidiaries or any holding company or any subsidiary of such holding company in order that they may buy shares in the Company or any such subsidiary or holding company. Further, subject to all applicable laws, the Company may give financial assistance to a trustee for the acquisition of shares in the Company or shares in any such subsidiary or holding company to be held for the benefit of employees of the Company, its subsidiaries, any holding company of the Company or any subsidiary of any such holding company (including salaried Directors).

*2.2.6 Disclosure of interest in contracts with the Company or any of its subsidiaries*

No Director or proposed Director shall be disqualified by his office from contracting with the Company either as vendor, purchaser or otherwise nor shall any such contract or any contract or arrangement entered into by or on behalf of the Company with any person, company or partnership of or in which any Director shall be a member or otherwise interested be capable on that account of being avoided, nor shall any Director so contracting or being any member or so interested be liable to account to the Company for any profit so realised by any such contract or arrangement by reason only of such Director holding that office or the fiduciary relationship thereby established. If to the knowledge of a Director, he or any of his associates, is in any way, whether directly or indirectly, interested in a contract or arrangement or proposed contract or arrangement with the Company, he must declare the nature of his or, as the case may be, any of his associates' interest at the earliest meeting of the board at which it is practicable for him to do so, either specifically or by way of a general notice stating that, by reason of the facts specified in the notice, he is regarded as interested in any contract of a specific description which may subsequently be made by the Company.

A Director shall not be entitled to vote on (nor shall he be counted in the quorum in relation to) any resolution of the Directors in respect of any contract or arrangement or any other proposal in which the Director or any of his associates has any material interest and if he shall do so his vote shall not be counted (nor is he to be counted in the quorum for the resolution), but this prohibition shall not apply to any of the following matters, namely:

- (a) the giving to such Director or any of his associates of any security or indemnity in respect of money lent or obligations incurred by him or any of them at the request of or for the benefit of the Company or any of its subsidiaries;
- (b) the giving of any security or indemnity to a third party in respect of a debt or obligation of the Company or any of its subsidiaries for which the Director or any of his associates has himself/themselves assumed responsibility in whole or in part and whether alone or jointly under a guarantee or indemnity or by the giving of security;

- (c) any proposal concerning an offer of shares, debentures or other securities of or by the Company or any other company which the Company may promote or be interested in for subscription or purchase where the Director or any of his associates is/are or is/are to be interested as a participant in the underwriting or sub-underwriting of the offer;
- (d) any proposal concerning any other company in which the Director or any of his associates is/are interested only, whether directly or indirectly, as an officer, executive or shareholder or in which the Director or any of his associates is/are beneficially interested in shares of that company, provided that the Director and any of his associates, are not in aggregate beneficially interested in five % or more of the issued shares of any class of such company (or of any third company through which his interest or that of any of his associates is derived) or of the voting rights;
- (e) any proposal or arrangement concerning the benefit of employees of the Company or any of its subsidiaries including:
  - (i) the adoption, modification or operation of any employees' share scheme or any share incentive scheme or share option scheme under which the Director or any of his associates may benefit;
  - (ii) the adoption, modification or operation of a pension or provident fund or retirement, death or disability benefits scheme which relates both to Directors, their associates and employees of the Company or any of its subsidiaries and does not provide in respect of any Director or any of his associates as such any privilege or advantage not generally accorded to the class of persons to which such scheme or fund relates; and
  - (iii) any contract or arrangement in which the Director or any of his associates is/are interested in the same manner as other holders of shares or debentures or other securities of the Company by virtue only of his interest in shares or debentures or other securities of the Company.

#### *2.2.7 Remuneration*

Our Directors shall be entitled to receive by way of remuneration for their services such sum as shall from time to time be determined by the Directors, or the Company in general meeting, as the case may be, such sum (unless otherwise directed by the resolution by which it is determined) to be divided amongst the Directors in such proportions and in such manner as they may agree, or failing agreement, equally, except that in such event any Director holding office for less than the whole of the relevant period in respect of which the remuneration is paid shall only rank in such division in proportion to the time during such period for which he has held office. Such remuneration shall be in addition to any other remuneration to which a Director who holds any salaried employment or office in the Company may be entitled by reason of such employment or office.

Our Directors shall also be entitled to be paid all expenses, including travel expenses, reasonably incurred by them in or about the performance of their duties as Directors including their expenses of travelling to and from board meetings, committee meetings or general meetings or otherwise incurred whilst engaged on the business of the Company or in the discharge of their duties as Directors.

Our Directors may grant special remuneration to any Director who shall perform any special or extra services at the request of the Company. Such special remuneration may be made payable to such Director in addition to or in substitution for his ordinary remuneration as a Director, and may be made payable by way of salary, commission or participation in profits or otherwise as may be agreed.

The remuneration of an executive Director or a Director appointed to any other office in the management of the Company shall from time to time be fixed by the Directors and may be by way of salary, commission or participation in profits or otherwise or by all or any of those modes and with such other benefits (including share option and/or pension and/or gratuity and/or other benefits on retirement) and allowances as the Directors may from time to time decide. Such remuneration shall be in addition to such remuneration as the recipient may be entitled to receive as a Director.

#### *2.2.8 Retirement, appointment and removal*

Our Directors shall have power at any time and from time to time to appoint any person to be a Director, either to fill a casual vacancy or as an addition to the existing Directors. Any Director so appointed to fill a casual vacancy shall hold office only until the next general meeting of the Company and shall then be eligible for re-election at that meeting and any Director so appointed as an addition to the existing Directors shall hold office only until the next annual general meeting of the Company and shall then be eligible for re-election at that meeting.

The Company may by ordinary resolution remove any Director (including a Managing Director or other executive Director) before the expiration of his period of office notwithstanding anything in the Articles of Association or in any agreement between the Company and such Director (but without prejudice to any claim for compensation or damages payable to him in respect of the termination of his appointment as Director or of any other appointment or office as a result of the termination of his appointment as Director). The Company may by ordinary resolution appoint another person in his place. Any Director so appointed shall hold office during such time only as the Director in whose place he is appointed would have held the same if he had not been removed. The Company may also by ordinary resolution elect any person to be a Director, either to fill a casual vacancy or as an addition to the existing Directors. No person shall, unless recommended by the Directors, be eligible for election to the office of Director at any general meeting unless, during the period, which shall be at least seven days, commencing no earlier than the day after the despatch of the notice of the meeting appointed for such election and ending no later than seven days prior to the date of such meeting, there has been given to the Secretary of the Company notice in writing by a member of the Company (not being the person to be proposed) entitled to attend and vote at the meeting for which such notice is given of his intention to propose such person for election and also notice in writing signed by the person to be proposed of his willingness to be elected.

There is no shareholding qualification for Directors nor is there any specified age limit for Directors.

The office of a Director shall be vacated:

- (a) if he resigns his office by notice in writing to the Company at its registered office or its principal office in Hong Kong;
- (b) if an order is made by any competent court or official on the grounds that he is or may be suffering from mental disorder or is otherwise incapable of managing his affairs and the Directors resolve that his office be vacated;
- (c) if, without leave, he is absent from meetings of the Directors (unless an alternate Director appointed by him attends) for 12 consecutive months, and the Directors resolve that his office be vacated;
- (d) if he becomes bankrupt or has a receiving order made against him or suspends payment or compounds with his creditors generally;

- (e) if he ceases to be or is prohibited from being a Director by law or by virtue of any provision in the Articles of Association;
- (f) if he is removed from office by notice in writing served upon him signed by not less than three-fourths in number (or, if that is not a round number, the nearest lower round number) of the Directors (including himself) for the time being then in office; or
- (g) if he shall be removed from office by an ordinary resolution of the members of the Company under the Articles of Association.

At every annual general meeting of the Company one-third of the Directors for the time being, or, if their number is not three or a multiple of three, then the number nearest to, but not less than, one third, shall retire from office by rotation provided that every Director (including those appointed for a specific term) shall be subject to retirement by rotation at least once every three years. A retiring Director shall retain office until the close of the meeting at which he retires and shall be eligible for reelection thereat. The Company at any annual general meeting at which any Directors retire may fill the vacated office by electing a like number of persons to be Directors.

#### 2.2.9 *Borrowing powers*

Our Directors may from time to time at their discretion exercise all the powers of the Company to raise or borrow or to secure the payment of any sum or sums of money for the purposes of the Company and to mortgage or charge its undertaking, property and assets (present and future) and uncalled capital or any part thereof.

The rights of the Directors to exercise these powers may only be varied by a special resolution.

#### 2.2.10 *Proceedings of the Board*

Our Directors may meet together for the despatch of business, adjourn and otherwise regulate their meetings and proceedings as they think fit in any part of the world. Questions arising at any meeting shall be determined by a majority of votes. In the case of an equality of votes, the chairman of the meeting shall have a second or casting vote.

#### 2.2.11 *Transaction with relevant companies*

Any transaction that is proposed to be entered into between the Company (or any of its subsidiaries) and a company in which the controlling member (as defined in the Listing Rules) of the Company or its members, individually or collectively, owns a direct or indirect equity interest of 10% or above (the “**Relevant Company**”) shall be approved in the manner described in and in compliance with the procedures set out in Articles of Association.

A transaction entered into by the Company with any connected person or any Relevant Company is required to be approved by way of a resolution passed by a majority of the Company’s non-executive Directors and independent non-executive Directors, provided that any non-executive Director or independent non-executive Director interested in the transactions in question will declare his or her interest and will abstain from voting on such matters.

In the event that a Director has a conflict of interest, such Director will not participate or be involved in matters relating to the relevant continuing connected transactions between the Company and any connected person or any transaction with any Relevant Company (meaning that he will not be involved in deliberations of the Board in respect of such matters, nor will he have any operational responsibility in relation to such matters).

The disinterested Directors, and in particular the independent non-executive Directors, will participate in monitoring the conduct of and operations in relation to transactions between the Company and any connected person or any Relevant Company and will not solely rely on information in relation to such transactions provided by Directors and others who are not so disinterested.

### **2.3 Alteration to constitutional documents**

Subject to the Companies Law, no alteration or amendment to the Memorandum or Articles of Association may be made except by special resolution.

### **2.4 Variation of rights of existing shares or classes of shares**

If at any time the share capital of the Company is divided into different classes of shares, all or any of the rights attached to any class of shares for the time being issued (unless otherwise provided for in the terms of issue of the shares of that class) may, subject to the provisions of the Companies Law, be varied or abrogated either with the consent in writing of the holders of not less than three-fourths in nominal value of the issued shares of that class or with the sanction of a special resolution passed at a separate meeting of the holders of the shares of that class. To every such separate meeting all the provisions of the Articles of Association relating to general meetings shall *mutatis mutandis* apply, but so that the quorum for the purposes of any such separate meeting and of any adjournment thereof shall be a person or persons together holding (or representing by proxy or duly authorised representative) at the date of the relevant meeting not less than one-third in nominal value of the issued shares of that class.

The special rights conferred upon the holders of shares of any class shall not, unless otherwise expressly provided in the rights attaching to or the terms of issue of such shares, be deemed to be varied by the creation or issue of further shares ranking *pari passu* therewith.

### **2.5 Alteration of Capital**

The Company in general meeting may, from time to time, whether or not all the shares for the time being authorised shall have been issued and whether or not all the shares for the time being issued shall have been fully paid up, by ordinary resolution, increase its share capital by the creation of new shares, such new capital to be of such amount and to be divided into shares of such respective amounts as the resolution shall prescribe.

The Company may from time to time by ordinary resolution:

2.5.1 consolidate and divide all or any of its share capital into shares of larger amount than its existing shares. On any consolidation of fully paid shares and division into shares of larger amount, the Directors may settle any difficulty which may arise as they think expedient and in particular (but without prejudice to the generality of the foregoing) may as between the holders of shares to be consolidated determine which particular shares are to be consolidated into each consolidated share, and if it shall happen that any person shall become entitled to fractions of a consolidated share or shares, such fractions may be sold by some person appointed by the Directors for that purpose and the person so appointed may transfer the shares so sold to the purchaser thereof and the validity of such transfer shall not be questioned, and so that the net proceeds of such sale (after deduction of the expenses of such sale) may either be distributed among the persons who would otherwise be entitled to a fraction or fractions of a consolidated share or shares rateably in accordance with their rights and interests or may be paid to the Company for the Company's benefit;

2.5.2 cancel any shares which at the date of the passing of the resolution have not been taken or agreed to be taken by any person, and diminish the amount of its share capital by the amount of the shares so cancelled subject to the provisions of the Companies Law; and

2.5.3 sub-divide its shares of any of them into shares of smaller amount than is fixed by the Memorandum of Association, subject nevertheless to the provisions of the Companies Law, and so that the resolution whereby any share is sub-divided may determine that, as between the holders of the shares resulting from such sub-division, one or more of the shares may have any such preferred or other special rights, over, or may have such deferred rights or be subject to any such restrictions as compared with the others as the company has power to attach to unissued or new shares.

The Company may by special resolution reduce its share capital or any capital redemption reserve in any manner authorised and subject to any conditions prescribed by the Companies Law.

## **2.6 Special resolution — majority required**

A “special resolution” is defined in the Articles of Association to have the meaning ascribed thereto in the Companies Law, for which purpose, the requisite majority shall be not less than three-fourths of the votes of such members of the Company as, being entitled to do so, vote in person or, in the case of corporations, by their duly authorised representatives or, where proxies are allowed, by proxy at a general meeting of which notice specifying the intention to propose the resolution as a special resolution has been duly given and includes a special resolution approved in writing by all of the members of the Company entitled to vote at a general meeting of the Company in one or more instruments each signed by one or more of such members, and the effective date of the special resolution so adopted shall be the date on which the instrument or the last of such instruments (if more than one) is executed. In contrast, an “ordinary resolution” is defined in the Articles of Association to mean a resolution passed by a simple majority of the votes of such members of the Company as, being entitled to do so, vote in person or, in the case of corporations, by their duly authorised representatives or, where proxies are allowed, by proxy at a general meeting held in accordance with the Articles of Association and includes an ordinary resolution approved in writing by all the members of the Company aforesaid.

## **2.7 Voting rights**

Subject to any special rights, privileges or restrictions as to voting for the time being attached to any class or classes of shares, at any general meeting, every member present in person (or, in the case of a member being a corporation, by its duly authorised representative) or by proxy shall have one vote for each share registered in his name in the register of members of the Company.

Where any member of the Company is, under the Listing Rules, required to abstain from voting on any particular resolution or is restricted to voting only for or only against any particular resolution, any votes cast by or on behalf of such member in contravention of such requirement or restriction shall not be counted.

In the case of joint registered holders of any share, any one of such persons may vote at any meeting, either personally or by proxy, in respect of such share as if he were solely entitled thereto; but if more than one of such joint holders be present at any meeting personally or by proxy, that one of the said persons so present being the most or, as the case may be, the more senior shall alone be entitled to vote in respect of the relevant joint holding and, for this purpose, seniority shall be determined by reference to the order in which the names of the joint holders stand on the register in respect of the relevant joint holding.

A member of the Company in respect of whom an order has been made by any competent court or official on the grounds that he is or may be suffering from mental disorder or is otherwise incapable of managing his affairs may vote by any person authorised in such circumstances to do so and such person may vote by proxy.

Save as expressly provided in the Articles of Association or as otherwise determined by the Directors, no person other than a member of the Company duly registered and who shall have paid all sums for the time being due from him payable to the Company in respect of his shares shall be entitled to be present or to vote (save as proxy for another member of the Company), or to be counted in a quorum, either personally or by proxy at any general meeting.

At any general meeting a resolution put to the vote of the meeting shall be decided on a poll.

On a poll votes may be given either personally or by proxy.

If a recognised clearing house (or its nominee) is a member of the Company it may authorise such person or persons as it thinks fit to act as its proxy(ies) or representative(s) at any general meeting of the Company or at any general meeting of any class of members of the Company provided that, if more than one person is so authorised, the authorisation or proxy form shall specify the number and class of shares in respect of which each such person is so authorised. The person so authorised will be deemed to have been duly authorised without the need of producing any documents of title, notarised authorisation and/or further evidence for substantiating the facts that is duly authorised. A person authorised pursuant to this provision shall be entitled to exercise the same rights and powers on behalf of the recognised clearing house (or its nominee) which he represents as that recognised clearing house (or its nominee) could exercise if it were an individual member of the Company holding the number and class of shares specified in such authorisation or proxy form.

## **2.8 Annual general meetings**

The Company shall in each year hold a general meeting as its annual general meeting in addition to any other general meeting in that year and shall specify the meeting as such in the notice calling it; and not more than 15 months (or such longer period as the Stock Exchange may authorise) shall elapse between the date of one annual general meeting of the Company and that of the next.

## **2.9 Accounts and audit**

Our Directors shall cause to be kept such books of account as are necessary to give a true and fair view of the state of the Company's affairs and to show and explain its transactions and otherwise in accordance with the Companies Law.

Our Directors shall from time to time determine whether, and to what extent, and at what times and places and under what conditions or regulations, the accounts and books of the Company, or any of them, shall be open to the inspection of members of the Company (other than officers of the Company) and no such member shall have any right of inspecting any accounts or books or documents of the Company except as conferred by the Companies Law or any other relevant law or regulation or as authorised by the Directors or by the Company in general meeting.

Our Directors shall, commencing with the first annual general meeting, cause to be prepared and to be laid before the members of the Company at every annual general meeting a profit and loss account for the period, in the case of the first account, since the incorporation of the Company and, in any other case, since the preceding account, together with a balance sheet as at the date at which the profit and loss account is made up and a Director's report with respect to the profit or loss of the Company for the period covered by the profit and loss account and the state of the Company's affairs as at the end of such period, an auditor's report on such accounts and such other reports and accounts as may be required by law. Copies of those documents to be laid before the members of the Company at an annual general meeting shall not less than 21 days before the date of the meeting, be sent in the

manner in which notices may be served by the Company as provided in the Articles of Association to every member of the Company and every holder of debentures of the Company provided that the Company shall not be required to send copies of those documents to any person of whose address the Company is not aware or to more than one of the joint holders of any shares or debentures.

The Company shall at any annual general meeting appoint an auditor or auditors of the Company who shall hold office until the next annual general meeting. The remuneration of the auditors shall be fixed by the Company at the annual general meeting at which they are appointed provided that in respect of any particular year the Company in general meeting may delegate the fixing of such remuneration to the Directors.

#### **2.10 Notice of meetings and business to be conducted thereat**

An annual general meeting and any extraordinary general meeting called for the passing of a special resolution shall be called by not less than 21 days' and not less than 20 business days' notice in writing and any other extraordinary general meeting shall be called by not less than 14 days' and not less than 10 business days' notice in writing. Subject to the requirement under the Listing Rules, the notice shall be exclusive of the day on which it is served or deemed to be served and of the day for which it is given, and shall specify the time, place and agenda of the meeting, particulars of the resolutions to be considered at the meeting and, in the case of special business, the general nature of that business. The notice convening an annual general meeting shall specify the meeting as such, and the notice convening a meeting to pass a special resolution shall specify the intention to propose the resolution as a special resolution. Notice of every general meeting shall be given to the auditors and all members of the Company (other than those who, under the provisions of the Articles of Association or the terms of issue of the shares they hold, are not entitled to receive such notice from the Company).

Notwithstanding that a meeting of the Company is called by shorter notice than that mentioned above, it shall be deemed to have been duly called if it is so agreed:

- (a) in the case of a meeting called as an annual general meeting, by all members of the Company entitled to attend and vote thereat or their proxies; and
- (b) in the case of any other meeting, by a majority in number of the members having a right to attend and vote at the meeting, being a majority together holding not less than 95% in nominal value of the shares giving that right.

All business shall be deemed special that is transacted at an extraordinary general meeting and also all business shall be deemed special that is transacted at an annual general meeting with the exception of the following, which shall be deemed ordinary business:

- (a) the declaration and sanctioning of dividends;
- (b) the consideration and adoption of the accounts and balance sheets and the reports of the Directors and the auditors and other documents required to be annexed to the balance sheet;
- (c) the election of Directors in place of those retiring;
- (d) the appointment of auditors;
- (e) the fixing of, or the determining of the method of fixing of, the remuneration of the Directors and of the auditors;

- (f) the granting of any mandate or authority to the Directors to offer, allot, grant options over or otherwise dispose of the unissued shares of the Company representing not more than 20 per cent. (or such other percentage as may from time to time be specified in the Listing Rules) in nominal value of its then existing issued share capital and the number of any securities repurchased pursuant to sub-paragraph (g) below; and
- (g) the granting of any mandate or authority to the Directors to repurchase securities of the Company.

### **2.11 Transfer of Shares**

Transfers of shares may be effected by an instrument of transfer in the usual common form or in such other form as the Directors may approve which is consistent with the standard form of transfer as prescribed by the Stock Exchange.

The instrument of transfer shall be executed by or on behalf of the transferor and, unless the Directors otherwise determine, the transferee, and the transferor shall be deemed to remain the holder of the share until the name of the transferee is entered in the register of members of the Company in respect thereof. All instruments of transfer shall be retained by the Company.

Our Directors may refuse to register any transfer of any share which is not fully paid up or on which the Company has a lien. Our Directors may also decline to register any transfer of any shares unless:

- (a) the instrument of transfer is lodged with the Company accompanied by the certificate for the shares to which it relates (which shall upon the registration of the transfer be cancelled) and such other evidence as the Directors may reasonably require to show the right of the transferor to make the transfer;
- (b) the instrument of transfer is in respect of only one class of shares;
- (c) the instrument of transfer is properly stamped (in circumstances where stamping is required);
- (d) in the case of a transfer to joint holders, the number of joint holders to whom the share is to be transferred does not exceed four;
- (e) the shares concerned are free of any lien in favour of the Company; and
- (f) a fee of such maximum as the Stock Exchange may from time to time determine to be payable (or such lesser sum as the Directors may from time to time require) is paid to the Company in respect thereof.

If the Directors refuse to register a transfer of any share they shall, within two months after the date on which the instrument of transfer was lodged with the Company, send to each of the transferor and the transferee notice of such refusal.

The registration of transfers may, on 14 days' notice being given by advertisement published on the Stock Exchange's website and the Company's website in the manner prescribed under the Listing Rules or, subject to the Listing Rules, by electronic communication in the manner in which notices may be served by the Company by electronic means as provided in the Articles of Association or by advertisement published in the newspapers, be suspended and the register of members of the Company closed at such times for such periods as the Directors may from time to time determine, provided that the registration of transfers shall not be suspended or the register closed for more than 30 days in any year (or such longer period as the members of the Company may by ordinary resolution determine provided that such period shall not be extended beyond 60 days in any year).

**2.12 Power of the Company to purchase its own Shares**

The Company is empowered by the Companies Law and the Articles of Association to purchase its own shares subject to certain restrictions and the Directors may only exercise this power on behalf of the Company subject to the authority of its members in general meeting as to the manner in which they do so and to any applicable requirements imposed from time to time by the Stock Exchange and the Securities and Futures Commission of Hong Kong.

**2.13 Power of any subsidiary of the Company to own Shares**

There are no provisions in the Articles of Association relating to the ownership of shares by a subsidiary.

**2.14 Dividends and other methods of distributions**

Subject to the Companies Law and Articles of Association, the Company in general meeting may declare dividends in any currency but no dividends shall exceed the amount recommended by the Directors.

No dividend may be declared or paid other than out of profits and reserves of the Company lawfully available for distribution, including share premium.

Unless and to the extent that the rights attached to any shares or the terms of issue thereof otherwise provide, all dividends shall (as regards any shares not fully paid throughout the period in respect of which the dividend is paid) be apportioned and paid pro rata according to the amounts paid up on the shares during any portion or portions of the period in respect of which the dividend is paid. For these purposes no amount paid up on a share in advance of calls shall be treated as paid up on the share.

Our Directors may from time to time pay to the members of the Company such interim dividends as appear to the Directors to be justified by the profits of the Company. Our Directors may also pay half-yearly or at other intervals to be selected by them at a fixed rate if they are of the opinion that the profits available for distribution justify the payment.

Our Directors may retain any dividends or other moneys payable on or in respect of a share upon which the Company has a lien, and may apply the same in or towards satisfaction of the debts, liabilities or engagements in respect of which the lien exists. Our Directors may also deduct from any dividend or other monies payable to any member of the Company all sums of money (if any) presently payable by him to the Company on account of calls, instalments or otherwise.

No dividend shall carry interest against the Company.

Whenever the Directors or the Company in general meeting have resolved that a dividend be paid or declared on the share capital of the Company, the Directors may further resolve: (a) that such dividend be satisfied wholly or in part in the form of an allotment of shares credited as fully paid up on the basis that the shares so allotted are to be of the same class as the class already held by the allottee, provided that the members of the Company entitled thereto will be entitled to elect to receive such dividend (or part thereof) in cash in lieu of such allotment; or (b) that the members of the Company entitled to such dividend will be entitled to elect to receive an allotment of shares credited as fully paid up in lieu of the whole or such part of the dividend as the Directors may think fit on the basis that the shares so allotted are to be of the same class as the class already held by the allottee. The Company may upon the recommendation of the Directors by ordinary resolution resolve in respect of any one particular dividend of the Company that notwithstanding the foregoing a dividend may be satisfied wholly in the form of an allotment of shares credited as fully paid without offering any right to members of the Company to elect to receive such dividend in cash in lieu of such allotment.

Any dividend, interest or other sum payable in cash to a holder of shares may be paid by check or warrant sent through the post addressed to the registered address of the member of the Company entitled, or in the case of joint holders, to the registered address of the person whose name stands first in the register of members of the Company in respect of the joint holding to such person and to such address as the holder or joint holders may in writing direct. Every check or warrant so sent shall be made payable to the order of the holder or, in the case of joint holders, to the order of the holder whose name stands first on the register of members of the Company in respect of such shares, and shall be sent at his or their risk and the payment of any such check or warrant by the bank on which it is drawn shall operate as a good discharge to the Company in respect of the dividend and/or bonus represented thereby, notwithstanding that it may subsequently appear that the same has been stolen or that any endorsement thereon has been forged. The Company may cease sending such checks for dividend entitlements or dividend warrants by post if such checks or warrants have been left uncashed on two consecutive occasions. However, the Company may exercise its power to cease sending checks for dividend entitlements or dividend warrants after the first occasion on which such a check or warrant is returned undelivered. Any one of two or more joint holders may give effectual receipts for any dividends or other moneys payable or property distributable in respect of the shares held by such joint holders.

Any dividend unclaimed for six years from the date of declaration of such dividend may be forfeited by the Directors and shall revert to the Company.

Our Directors may, with the sanction of the members of the Company in general meeting, direct that any dividend be satisfied wholly or in part by the distribution of specific assets of any kind, and in particular of paid up shares, debentures or warrants to subscribe securities of any other company, and where any difficulty arises in regard to such distribution the Directors may settle it as they think expedient, and in particular may disregard fractional entitlements, round the same up or down or provide that the same shall accrue to the benefit of the Company, and may fix the value for distribution of such specific assets and may determine that cash payments shall be made to any members of the Company upon the footing of the value so fixed in order to adjust the rights of all parties, and may vest any such specific assets in trustees as may seem expedient to the Directors.

### **2.15 Proxies**

Any member of the Company entitled to attend and vote at a meeting of the Company shall be entitled to appoint another person who must be an individual as his proxy to attend and vote instead of him and a proxy so appointed shall have the same right as the member to speak at the meeting. A proxy need not be a member of the Company.

The instrument appointing a proxy shall be in writing under the hand of the appointor or his attorney authorised in writing or if the appointor is a corporation either under its seal or under the hand of an officer, attorney or other person authorised to sign the same.

The instrument appointing a proxy and (if required by the Directors) the power of attorney or other authority (if any) under which it is signed, or a notarially certified copy of such power or authority, shall be delivered at the registered office of the Company (or at such other place as may be specified in the notice convening the meeting or in any notice of any adjournment or, in either case, in any document sent therewith) not less than 48 hours before the time appointed for holding the meeting or adjourned meeting at which the person named in the instrument proposes to vote or, in the case of a poll taken subsequently to the date of a meeting or adjourned meeting, not less than 48 hours before the time appointed for the taking of the poll and in default the instrument of proxy shall not be treated as valid. No instrument appointing a proxy shall be valid after the expiration of 12 months from the date named in it as the date of its execution. Delivery of any instrument appointing a proxy shall not preclude a member of the Company from attending and voting in person at the meeting or poll concerned and, in such event, the instrument appointing a proxy shall be deemed to be revoked.

**2.16 Calls on Shares and forfeiture of Shares**

Our Directors may from time to time make calls upon the members of the Company in respect of any moneys unpaid on their shares (whether on account of the nominal amount of the shares or by way of premium) and not by the conditions of allotment thereof made payable at fixed times and each member of the Company shall (subject to the Company serving upon him at least 14 days' notice specifying the time and place of payment) pay to the Company at the time and place so specified the amount called on his shares. A call may be revoked or postponed as the Directors may determine. A person upon whom a call is made shall remain liable on such call notwithstanding the subsequent transfer of the shares in respect of which the call was made.

A call may be made payable either in one sum or by instalments and shall be deemed to have been made at the time when the resolution of the Directors authorising the call was passed. The joint holders of a share shall be jointly and severally liable to pay all calls and instalments due in respect of such share or other moneys due in respect thereof.

If a sum called in respect of a share shall not be paid before or on the day appointed for payment thereof, the person from whom the sum is due shall pay interest on the sum from the day appointed for payment thereof to the time of actual payment at such rate, not exceeding 15% per annum, as the Directors may determine, but the Directors shall be at liberty to waive payment of such interest wholly or in part.

If any call or instalment of a call remains unpaid on any share after the day appointed for payment thereof, the Directors may at any time during such time as any part thereof remains unpaid serve a notice on the holder of such shares requiring payment of so much of the call or instalment as is unpaid together with any interest which may be accrued and which may still accrue up to the date of actual payment.

The notice shall name a further day (not being less than 14 days from the date of service of the notice) on or before which, and the place where, the payment required by the notice is to be made, and shall state that in the event of non-payment on or before the time and at the place appointed, the shares in respect of which such call was made or instalment is unpaid will be liable to be forfeited.

If the requirements of such notice are not complied with, any share in respect of which such notice has been given may at any time thereafter, before payment of all calls or instalments and interest due in respect thereof has been made, be forfeited by a resolution of the Directors to that effect. Such forfeiture shall include all dividends and bonuses declared in respect of the forfeited shares and not actually paid before the forfeiture. A forfeited share shall be deemed to be the property of the Company and may be sold, re-allotted or otherwise disposed of.

A person whose shares have been forfeited shall cease to be a member of the Company in respect of the forfeited shares but shall, notwithstanding the forfeiture, remain liable to pay to the Company all moneys which at the date of forfeiture were payable by him to the Company in respect of the shares, together with (if the Directors shall in their discretion so require) interest thereon at such rate not exceeding 15% per annum as the Directors may prescribe from the date of forfeiture until payment, and the Directors may enforce payment thereof without being under any obligation to make any allowance for the value of the shares forfeited, at the date of forfeiture.

**2.17 Inspection of register of members**

The register of members of the Company shall be kept in such manner as to show at all times the members of the Company for the time being and the shares respectively held by them. The register may, on 14 days' notice being given by advertisement on the Stock Exchange's website and the Company's website in the manner prescribed under the Listing Rules, or subject to the Listing Rules, by electronic communication in the manner in which notices may be served by the Company by electronic means as provided in the Articles of Association or by advertisement published in the newspapers, be closed at such times and for such periods as the Directors may from time to time determine either generally or in respect of any class of shares, provided that the register shall not be closed for more than 30 days in any year (or such longer period as the members of the Company may by ordinary resolution determine provided that such period shall not be extended beyond 60 days in any year).

Any register of members kept in Hong Kong shall during normal business hours (subject to such reasonable restrictions as the Directors may impose) be open to inspection by any member of the Company without charge and by any other person on payment of such fee not exceeding HK\$2.50 (or such higher amount as may from time to time be permitted under the Listing Rules) as the Directors may determine for each inspection.

**2.18 Quorum for meetings and separate class meetings**

No business shall be transacted at any general meeting unless a quorum is present when the meeting proceeds to business, but the absence of a quorum shall not preclude the appointment, choice or election of a chairman which shall not be treated as part of the business of the meeting.

Two members of the Company present in person or by proxy shall be a quorum provided always that if the Company has only one member of record the quorum shall be that one member present in person or by proxy.

A corporation being a member of the Company shall be deemed for the purpose of the Articles of Association to be present in person if represented by its duly authorised representative being the person appointed by resolution of the directors or other governing body of such corporation or by power of attorney to act as its representative at the relevant general meeting of the Company or at any relevant general meeting of any class of members of the Company.

The quorum for a separate general meeting of the holders of a separate class of shares of the Company is described in sub-paragraph 2.4 above.

**2.19 Rights of minorities in relation to fraud or oppression**

There are no provisions in the Articles of Association concerning the rights of minority shareholders in relation to fraud or oppression.

**2.20 Procedure on liquidation**

If the Company shall be wound up, and the assets available for distribution amongst the members of the Company as such shall be insufficient to repay the whole of the paid-up capital, such assets shall be distributed so that, as nearly as may be, the losses shall be borne by the members of the Company in proportion to the capital paid up, or which ought to have been paid up, at the commencement of the winding up on the shares held by them respectively. And if in a winding up the assets available for distribution amongst the members of the Company shall be more than sufficient to repay the whole of the capital paid up at the commencement of the winding up, the excess shall be distributed amongst the members of the Company in proportion to the capital paid up at the commencement of the winding up on the shares held by them respectively. The foregoing is without prejudice to the rights of the holders of shares issued upon special terms and conditions.

If the Company shall be wound up, the liquidator may with the sanction of a special resolution of the Company and any other sanction required by the Companies Law, divide amongst the members of the Company in specie or kind the whole or any part of the assets of the Company (whether they shall consist of property of the same kind or not) and may, for such purpose, set such value as he deems fair upon any property to be divided as aforesaid and may determine how such division shall be carried out as between the members or different classes of members of the Company. The liquidator may, with the like sanction, vest the whole or any part of such assets in trustees upon such trusts for the benefit of the members of the Company as the liquidator, with the like sanction and subject to the Companies Law, shall think fit, but so that no member of the Company shall be compelled to accept any assets, shares or other securities in respect of which there is a liability.

### **2.21 Untraceable members**

The Company shall be entitled to sell any shares of a member of the Company or the shares to which a person is entitled by virtue of transmission on death or bankruptcy or operation of law if: (i) all checks or warrants, not being less than three in number, for any sums payable in cash to the holder of such shares have remained uncashed for a period of 12 years; (ii) the Company has not during that time or before the expiry of the three month period referred to in (iv) below received any indication of the whereabouts or existence of the member; (iii) during the 12 year period, at least three dividends in respect of the shares in question have become payable and no dividend during that period has been claimed by the member; and (iv) upon expiry of the 12 year period, the Company has caused an advertisement to be published in the newspapers or subject to the Listing Rules, by electronic communication in the manner in which notices may be served by the Company by electronic means as provided in the Articles of Association, giving notice of its intention to sell such shares and a period of three months has elapsed since such advertisement and the Stock Exchange has been notified of such intention. The net proceeds of any such sale shall belong to the Company and upon receipt by the Company of such net proceeds it shall become indebted to the former member for an amount equal to such net proceeds.

## **SUMMARY OF CAYMAN ISLANDS COMPANY LAW AND TAXATION**

### **1 Introduction**

The Companies Law is derived, to a large extent, from the older Companies Acts of England, although there are significant differences between the Companies Law and the current Companies Act of England. Set out below is a summary of certain provisions of the Companies Law, although this does not purport to contain all applicable qualifications and exceptions or to be a complete review of all matters of corporate law and taxation which may differ from equivalent provisions in jurisdictions with which interested parties may be more familiar.

### **2 Incorporation**

The Company was incorporated as an exempted company with limited liability on 16 December 2002 under the Companies Law. As an exempted company, the operations of the Company must be conducted mainly outside the Cayman Islands. The Company is required to file an annual return each year with the Registrar of Companies of the Cayman Islands which shall be in the form of a declaration that:

- (a) since the previous return or since registration of the Company, as the case may be, there has been no alteration in the memorandum of association of the Company other than an alteration in the name of the Company effected in accordance with section 31 of the Companies Law or an alteration already reported in accordance with section 10 of the Companies Law;
- (b) the operations of the Company since the last return or since registration of the Company, as the case may be, have been mainly outside the Cayman Islands; and

- (c) the provisions of Section 174 of the Companies Law have been and are being complied with.

Section 174 of the Companies Law requires that the Company shall not trade in the Cayman Islands with any person, firm or corporation except in furtherance of the business of the Company carried on outside the Cayman Islands. This does not prevent the Company from effecting and concluding contracts in the Cayman Islands and exercising in the Cayman Islands all of its powers necessary for the carrying on of its business outside the Cayman Islands.

Based upon an authorised share capital of US\$2,000, the Company is currently required to pay an annual fee of US\$573.17. This annual fee will increase to US\$731.17, effective 1 January 2010.

### **3 Share capital**

The Companies Law permits a company to issue ordinary shares, preference shares, redeemable shares or any combination thereof.

The Companies Law provides that where a company issues shares at a premium, whether for cash or otherwise, a sum equal to the aggregate amount of the value of the premia on those shares shall be transferred to an account called the “share premium account”. At the option of a company, these provisions may not apply to premia on shares of that company allotted pursuant to any arrangement in consideration of the acquisition or cancellation of shares in any other company and issued at a premium. The Companies Law provides that the share premium account may be applied by a company, subject to the provisions, if any, of its memorandum and articles of association, in such manner as the company may from time to time determine including, but without limitation:

- (a) paying distributions or dividends to members;
- (b) paying up unissued shares of the company to be issued to members as fully paid bonus shares;
- (c) in the redemption and repurchase of shares (subject to the provisions of section 37 of the Companies Law);
- (d) writing-off the preliminary expenses of the company;
- (e) writing-off the expenses of, or the commission paid or discount allowed on, any issue of shares or debentures of the company; and
- (f) providing for the premium payable on redemption or purchase of any shares or debentures of the company.

No distribution or dividend may be paid to members out of the share premium account unless immediately following the date on which the distribution or dividend is proposed to be paid the company will be able to pay its debts as they fall due in the ordinary course of business.

The Companies Law provides that, subject to confirmation by the Grand Court of the Cayman Islands, a company limited by shares or a company limited by guarantee and having a share capital may, if so authorised by its articles of association, by special resolution reduce its share capital in any way.

Subject to the detailed provisions of the Companies Law, a company limited by shares or a company limited by guarantee and having a share capital may, if so authorised by its articles of association, issue shares which are to be redeemed or are liable to be redeemed at the option of the company or a shareholder. In addition, such a company may, if authorised to do so by its articles of association, purchase its own shares, including any redeemable shares. However, if the articles of association do not authorise the manner of purchase, a company cannot purchase any of its own shares

unless the manner of purchase has first been authorised by an ordinary resolution of the company. At no time may a company redeem or purchase its shares unless they are fully paid. A company may not redeem or purchase any of its shares if, as a result of the redemption or purchase, there would no longer be any member of the company holding shares. A payment out of capital by a company for the redemption or purchase of its own shares is not lawful unless immediately following the date on which the payment is proposed to be made, the company shall be able to pay its debts as they fall due in the ordinary course of business.

There is no statutory restriction in the Cayman Islands on the provision of financial assistance by a company to another person for the purchase of, or subscription for, its own or its holding company's shares. Accordingly, a company may provide financial assistance if the directors of the company consider, in discharging their duties of care and to act in good faith, for a proper purpose and in the interests of the company, that such assistance can properly be given. Such assistance should be on an arm's-length basis.

#### **4 Dividends and distributions**

With the exception of section 34 of the Companies Law, there are no statutory provisions relating to the payment of dividends. Based upon English case law which is likely to be persuasive in the Cayman Islands in this area, dividends may be paid only out of profits. In addition, section 34 of the Companies Law permits, subject to a solvency test and the provisions, if any, of the company's memorandum and articles of association, the payment of dividends and distributions out of the share premium account (see 3 above for further details).

#### **5 Shareholders' suits**

The Cayman Islands courts can be expected to follow English case law precedents including the exceptions to the rule in *Foss v. Harbottle* which permit a minority shareholder to commence a class action against or derivative actions in the name of the company to challenge (a) an act which is *ultra vires* the company or illegal, (b) an act which constitutes a fraud against the minority and the wrongdoers are themselves in control of the company, and (c) an action which requires a resolution with a qualified (or special) majority which has not been obtained).

#### **6 Protection of minorities**

In the case of a company (not being a bank) having a share capital divided into shares, the Grand Court of the Cayman Islands may, on the application of members holding not less than one fifth of the shares of the company in issue, appoint an inspector to examine into the affairs of the company and to report thereon in such manner as the Grand Court shall direct.

Any shareholder of a company may petition the Grand Court of the Cayman Islands which may make a winding up order if the court is of the opinion that it is just and equitable that the company should be wound up.

Claims against a company by its shareholders must, as a general rule, be based on the general laws of contract or tort applicable in the Cayman Islands or their individual rights as shareholders as established by the company's memorandum and articles of association.

The English common law rule that the majority will not be permitted to commit a fraud on the minority has been applied and followed by the courts of the Cayman Islands.

#### **7 Disposal of assets**

The Companies Law contains no specific restrictions on the powers of directors to dispose of assets of a company. As a matter of general law, in the exercise of those powers, the directors must discharge their duties of care and to act in good faith, for a proper purpose and in the interests of the company.

**8 Accounting and auditing requirements**

The Companies Law requires that a company shall cause to be kept proper books of account with respect to:

- (a) all sums of money received and expended by the company and the matters in respect of which the receipt and expenditure takes place;
- (b) all sales and purchases of goods by the company; and
- (c) the assets and liabilities of the company.

Proper books of account shall not be deemed to be kept if there are not kept such books as are necessary to give a true and fair view of the state of the company's affairs and to explain its transactions.

**9 Register of members**

An exempted company may, subject to the provisions of its articles of association, maintain its principal register of members and any branch registers at such locations, whether within or without the Cayman Islands, as its directors may, from time to time, think fit. There is no requirement under the Companies Law for an exempted company to make any returns of members to the Registrar of Companies in the Cayman Islands. The names and addresses of the members are, accordingly, not a matter of public record and are not available for public inspection.

**10 Inspection of books and records**

Members of the Company will have no general right under the Companies Law to inspect or obtain copies of the register of members or corporate records of the Company. They will, however, have such rights as may be set out in the Company's articles of association.

**11 Special resolutions**

The Companies Law provides that a resolution is a special resolution when it has been passed by a majority of not less than two-thirds (or such greater number as may be specified in the articles of association of the company) of such members as, being entitled to do so, vote in person or, where proxies are allowed, by proxy at a general meeting of which notice specifying the intention to propose the resolution as a special resolution has been duly given. Written resolutions signed by all the members for the time being of the Company may take effect as special resolutions if this is authorised by the articles of association of the Company.

**12 Subsidiary owning shares in parent**

The Companies Law does not prohibit a Cayman Islands company acquiring and holding shares in its parent company provided its objects so permit. The directors of any subsidiary making such acquisition must discharge their duties of care and to act in good faith, for a proper purpose and in the interests of the subsidiary.

**13 Reconstructions**

There are statutory provisions which facilitate reconstructions and amalgamations approved by a majority in number representing 75 per cent. in value of shareholders or creditors, depending on the circumstances, as are present at a meeting called for such purpose and thereafter sanctioned by the Grand Court of the Cayman Islands. Whilst a dissenting shareholder would have the right to express to the Grand Court his view that the transaction for which approval is sought would not provide the shareholders with a fair value for their shares, the Grand Court of the Cayman Islands is unlikely to disapprove the transaction on that ground alone in the absence of evidence of fraud or bad faith on

behalf of management and if the transaction were approved and consummated the dissenting shareholder would have no rights comparable to the appraisal rights (i.e. the right to receive payment in cash for the judicially determined value of their shares) ordinarily available, for example, to dissenting shareholders of United States corporations.

#### **14 Take-overs**

Where an offer is made by a company for the shares of another company and, within four months of the offer, the holders of not less than 90 per cent. of the shares which are the subject of the offer accept, the offeror may at any time within two months after the expiration of the said four months, by notice require the dissenting shareholders to transfer their shares on the terms of the offer. A dissenting shareholder may apply to the Grand Court of the Cayman Islands within one month of the notice objecting to the transfer. The burden is on the dissenting shareholder to show that the Grand Court should exercise its discretion, which it will be unlikely to do unless there is evidence of fraud or bad faith or collusion as between the offeror and the holders of the shares who have accepted the offer as a means of unfairly forcing out minority shareholders.

#### **15 Indemnification**

Cayman Islands law does not limit the extent to which a company's articles of association may provide for indemnification of officers and directors, except to the extent any such provision may be held by the Cayman Islands courts to be contrary to public policy (e.g. for purporting to provide indemnification against the consequences of committing a crime).

#### **16 Liquidation**

A company may be placed in liquidation compulsorily by an order of the court, or voluntarily (i) by a special resolution of its members if the company is solvent or (ii) by an ordinary resolution of its members if the company is insolvent. The liquidator's duties are to collect the assets of the company (including the amount (if any) due from the contributories (shareholders)), settle the list of creditors and discharge the company's liability to them, rateably if insufficient assets exist to discharge the liabilities in full, and to settle the list of contributories and divide the surplus assets (if any) amongst them in accordance with the rights attaching to the shares.

#### **17 Stamp duty on transfers**

No stamp duty is payable in the Cayman Islands on transfers of shares of Cayman Islands companies except those which hold interests in land in the Cayman Islands.

#### **18 Taxation**

Pursuant to section 6 of the Tax Concessions Law (1999 Revision) of the Cayman Islands, the Company has obtained an undertaking from the Governor in Council:

- (a) that no law which is enacted in the Cayman Islands imposing any tax to be levied on profits, income, gains or appreciations shall apply to the Company or its operations; and
- (b) in addition, that no tax to be levied on profits, income gains or appreciations or which is in the nature of estate duty or inheritance tax shall be payable:
  - (i) on or in respect of the shares, debentures or other obligations of the Company; and
  - (ii) by way of the withholding in whole or in part of any relevant payment as defined in Section 6(3) of the Tax Concessions Law (1999 Revision).

The undertaking is for a period of twenty years from 7 January 2003.

The Cayman Islands currently levy no taxes on individuals or corporations based upon profits, income, gains or appreciations and there is no taxation in the nature of inheritance tax or estate duty. There are no other taxes likely to be material to the Company levied by the Government of the Cayman Islands save certain stamp duties which may be applicable, from time to time, on certain instruments executed in or brought within the jurisdiction of the Cayman Islands. The Cayman Islands are not party to any double tax treaties.

**19 Exchange control**

There are no exchange control regulations or currency restrictions in the Cayman Islands.

**20 General**

Maples and Calder the Company's legal advisers on Cayman Islands law, have sent to the Company a letter of advice summarising aspects of Cayman Islands company law. This letter, together with a copy of the Companies Law, is available for inspection as referred to in the section headed "Documents available for inspection" in Appendix VII. Any person wishing to have a detailed summary of Cayman Islands company law or advice on the differences between it and the laws of any jurisdiction with which he/she is more familiar is recommended to seek independent legal advice.

## 1. FURTHER INFORMATION ABOUT THE COMPANY

### A. Incorporation

We incorporated as an exempted company in the Cayman Islands under the Companies Law on December 16, 2002. Our principal place of business is 7 Langshan First Road, Science and Technology Park, Nanshan District, Shenzhen, Guangdong Province, PRC. We have established a principal place of business in Hong Kong at Room 1902, 19/F Massmutual Tower, 38 Gloucester Road, Wanchai, Hong Kong and we registered as an oversea company in Hong Kong under Part XI of the Companies Ordinance on November 30, 2007. Wong Brothers & Co., Certified Public Accountants, of Room 1902, 19/F Massmutual Tower, 38 Gloucester Road, Wanchai, Hong Kong has been appointed as our agent for the acceptance of service of process in Hong Kong.

As we were incorporated in the Cayman Islands, we operate subject to Cayman Islands law and our constitution documents comprising a Memorandum and Articles. A summary of various provisions of our constitution and relevant aspects of Cayman Islands company law is set out in Appendix V to this prospectus.

### B. Changes in share capital of our Company

Pursuant to the extraordinary general meeting of our Company on November 25, 2009, the authorized share capital of our Company was increased from US\$800 to US\$2,000 by the creation of additional 1,200,000,000 Shares with effect from the Listing Date.

Immediately upon completion of the Global Offering and the Capitalization Issue but without taking into account any Shares which may be issued pursuant to the exercise of the Over-allotment Option, the Pre-IPO Options or any options which may be granted under the Share Option Scheme, the authorized share capital of our Company will be US\$2,000 divided into 2,000,000,000 Shares, of which 702,057,995 Shares will be allotted and issued or credited as fully paid, and 1,297,942,005 Shares will remain unissued. Other than pursuant to the exercise of the Over-allotment Option, the Pre-IPO Options or any options which may be granted under the Share Option Scheme, and save as otherwise disclosed herein, the Directors have no present intention to issue any part of the authorized but unissued share capital of our Company and, without the prior approval of the shareholders of our Company in general meeting, no issue of Shares will be made which would effectively alter the control of our Company.

Except as discussed above and in the paragraphs headed “Extraordinary general meeting of our Company” and “Corporate reorganization” below, there has been no alteration in our share capital since the date of our incorporation.

### C. Extraordinary general meeting of our Company

Our shareholders held an extraordinary general meeting on November 25, 2009 approving among other matters:

- (a) the authorized share capital of our Company was increased from US\$800 divided into 750,000,000 ordinary shares of a par value of US\$0.000001 each and 50,000,000 preferred shares of a par value of US\$0.000001 of which 50,000,000 shares have been designated as Series A preferred shares to US\$2,000 by the creation of an additional 1,200,000,000 shares with effect from the Listing Date;
- (b) the Capitalization Issue was approved, and the Directors were authorized to capitalize an aggregate amount of US\$421.24 standing to the credit of the share premium account of our Company and to appropriate such amount as capital to pay up in full at par 421,234,396 Shares for allotment and issue to the persons whose names appear on the register of members of our Company on November 25, 2009 in proportion to their then existing shareholdings in our Company, each ranking *pari passu* in all respects with the then existing issued Shares;

- (c) the Articles were adopted in substitution for and to the exclusion of the existing Articles conditional on the Listing of the Shares on the Stock Exchange on the Listing Date;
- (d) the conversion of the issued 30,599,999 Series A Preferred Shares into 30,599,999 Shares and the 19,400,001 unissued Series A Preferred Shares be re-classified and re-designated as 19,400,001 Shares on the Listing Date were approved such that the authorized share capital of the Company will be US\$2,000 divided into 2,000,000,000 Shares;
- (e) conditional on the Listing Committee of the Stock Exchange granting listing of and permission to deal in the Shares in issue and to be issued as mentioned in this prospectus and on the obligations of the Underwriters under the Underwriting Agreements becoming unconditional and not being terminated in accordance with the terms of the Underwriting Agreements or otherwise, in each case on or before such dates as may be specified in the Underwriting Agreements:
  - (i) the Global Offering and the Over-allotment Option were approved and the Directors were authorized to approve the allotment and issue of the Offer Shares and any Shares which are required to be issued if the Over-allotment Option is exercised;
  - (ii) the rules of the Share Option Scheme, the principal terms of which are set out in the section headed “Share Option Scheme” of this Appendix, were approved and adopted and the Directors were authorized to implement the same, to grant options to subscribe for Shares thereunder, and to allot and issue Shares pursuant to the exercise of options which may be granted under the Share Option Scheme;
  - (iii) a general unconditional mandate was given to the Directors to exercise all the powers to allot, issue and deal with, otherwise than by way of rights, scrip dividend schemes or similar arrangements in accordance with the Articles, or pursuant to the exercise of any options which have been granted under the Pre-IPO Stock Incentive Plans or may be granted under the Share Option Scheme or any other option scheme or similar arrangement for the time being adopted, Shares with an aggregate nominal amount not exceeding 20% of the aggregate nominal amount of the share capital of our Company in issue and to be issued pursuant to the Global Offering and the Capitalization Issue (excluding the aggregate nominal value of the share capital of our Company which may be issued pursuant to the exercise of the Over-allotment Option), such mandate to remain in effect until whichever is the earliest of:
    - (1) the conclusion of the next annual general meeting of our Company;
    - (2) the date by which the next annual general meeting of our Company is required by its articles of association or any applicable law to be held; or
    - (3) the date on which such mandate is revoked or varied by an ordinary resolution by the shareholders of the Company in general meeting;
  - (iv) a general unconditional mandate was given to the Directors authorizing them to exercise all powers of our Company to repurchase Shares with an aggregate nominal amount not exceeding 10% of the aggregate nominal amount of the share capital of our Company in issue and to be issued pursuant to the Global Offering and the Capitalization Issue (excluding the aggregate nominal value of the share capital of our Company which may be issued pursuant to the exercise of the Over-allotment Option), such mandate to remain in effect until whichever is the earliest of:
    - (1) the conclusion of the next annual general meeting of our Company;

- (2) the date by which the next annual general meeting of our Company is required to be held by the Articles or any applicable law;
- (3) the date on which such mandate is revoked or varied by an ordinary resolution by shareholders of the Company in general meeting; and
- (v) the general unconditional mandate mentioned in paragraph (iv) above was extended by the addition to the aggregate nominal value of the share capital of our Company which may be allotted or agreed conditionally or unconditionally to be allotted by the Directors pursuant to such general mandate of an amount representing the aggregate nominal value of the share capital of our Company repurchased by our Company pursuant to the mandate to repurchase Shares referred to in paragraph (iv) above provided that such extended amount shall not exceed 10% of the aggregate nominal value of the share capital of our Company in issue and to be issued pursuant to the Global Offering and the Capitalization Issue (excluding the aggregate nominal value of the share capital of our Company which may be issued pursuant to the exercise of the Over-allotment Option).

#### D. Corporate reorganization

In preparation for the listing of Shares on the Stock Exchange, the companies comprising our Group underwent a reorganization and our Company became the holding company of our Group. Our Reorganization involved the following:

- (a) On December 16, 2002, our Company was incorporated with an authorized share capital of US\$100 divided into 100,000,000 Shares of a par value of US\$0.000001 each.
- (b) On December 16, 2002, one Share was allotted and issued, credited as fully paid, at par to the initial subscriber, which was subsequently transferred to Hu Xiang on December 19, 2002.
- (c) On December 19, 2002, the authorized share capital of our Company was increased from US\$100 divided into 100,000,000 Shares of a par value of US\$0.000001 each to US\$800 divided into 750,000,000 Shares of a par value of US\$0.000001 each and 50,000,000 Preferred Shares of a par value of US\$0.000001 each, all of which were designated as Series A Preferred Shares.
- (d) On December 19, 2002, in consideration of the commitment by the grantees to provide and procure services to our Company, our Company allotted and issued a total of 74,499,999 Shares — 47,322,400 Shares to Qu Deqian, 9,312,500 Shares to Wang Beirong, 4,618,999 Shares to Hu Xiang, 4,946,800 Shares to Wang Guoying, 5,043,650 Shares to Shao Zhiguo and 3,255,650 Shares to the 39 Employee Shareholders. Pursuant to two declarations of trust dated December 19, 2002, of the 47,322,400 Shares, Qu Deqian held 41,720,000 Shares for the benefit of Shenzhen Weixiantong, and 5,602,400 Shares for the benefit of Hou Weigui respectively. Pursuant to a declaration of trust dated May 16, 2007, Shenzhen Weixiantong confirmed and acknowledged an earlier oral arrangement with the Beneficial Owners made on December 19, 2002 that since December 19, 2002, any interest in the 41,720,000 Shares had always been held in trust for the Beneficial Owners. The name and the number of Shares held by each of the Beneficial Owners are set forth in the chart entitled “Summary on the Beneficial Owners” under the sub-section headed “Our Reorganization” in the section headed “History and Development” to this prospectus.

- (e) On December 19, 2002, our Company entered into a subscription agreement with SB Asia, MOBI Shenzhen, Shenzhen Weixiantong, Qu Deqian, Wang Beirong, Hu Xiang, Wang Guoying, Shao Zhiguo, Hou Weigui and the 39 Employee Shareholders for the subscription of 25,500,000 Series A Preferred Shares by SB Asia. The 25,500,000 Series A Preferred Shares were allotted and issued to SB Asia on January 2, 2003.
- (f) On December 19, 2002, our Company issued to SB Asia the Series A Preferred Share Warrant, pursuant to which SB Asia is entitled to acquire during the exercise period such number of Series A Preferred Shares as is equal to a total consideration of RMB9,000,000 divided by an initial exercise price of RMB1.7647059 (subject to applicable adjustment).
- (g) On December 19, 2002, our Company issued to Shenzhen Weixiantong (acting for and on behalf of the Beneficial Owners) the Share Warrant, pursuant to which Shenzhen Weixiantong (acting for and on behalf of the Beneficial Owners) is entitled to acquire during the exercise period 208,600 Shares at a consideration of US\$1.00.
- (h) On December 19, 2002, our Company entered into an equity transfer agreement with the Initial Shareholders for the acquisition of the entire equity interest in MOBI Shenzhen at a consideration of RMB15,000,000. On January 21, 2003, MOBI Shenzhen was converted into a wholly foreign owned enterprise of our Company.
- (i) On December 19, 2002, the Shareholders' Agreement was entered into among our Company, MOBI Shenzhen, SB Asia, Shenzhen Weixiantong, Qu Deqian, Wang Beirong, Hu Xiang, Wang Guoying, Shao Zhiguo, Hou Weigui and the 39 Employee Shareholders setting out their respective rights and obligations as shareholders of our Company.

As of the Latest Practicable Date, we had 8 registered shareholders.

#### **E. Changes in the share capital of our subsidiaries**

Our subsidiaries are listed in the accountants' report, the text of which is set out in Appendix I.

In the two years preceding the date to this prospectus, other than the incorporation of MOBI Xian on April 29, 2008, there have been no alterations in the share capital of our subsidiaries.

#### **F. Repurchase by our Company of its own securities**

This paragraph sets forth information required by the Stock Exchange to be included in this prospectus concerning the repurchase by us of our own securities.

##### **(a) Provisions of the Listing Rules**

The Listing Rules permit companies with a primary listing on the Stock Exchange to repurchase their securities on the Stock Exchange subject to certain restrictions, the most important of which are summarized below:

##### **(i) Shareholders' approval**

All proposed repurchases of securities by a company with its primary listing on the Stock Exchange must be approved in advance by an ordinary resolution of shareholders, either by way of general mandate or by specific approval of a specific transaction.

As set forth in paragraph 1(C) of this Appendix, our Directors were given a general unconditional mandate to repurchase securities.

(ii) *Source of funds*

Repurchases must only be funded out of funds legally available for the purpose in accordance with the Articles, the Listing Rules and the applicable laws of the Cayman Islands. A company may not repurchase its own securities on the Stock Exchange for a consideration other than cash or for settlement otherwise than in accordance with the trading rules of the Stock Exchange from time to time. Any repurchases may be made out of funds legally available for the purpose, namely profits or the proceeds of a fresh issue of shares made for the purpose, or, if so authorized by its articles and subject to the Companies Law, out of capital. Any premium on a purchase may be made out of profits or the company's share premium account or, if so authorized by its articles and subject to the Companies Law, out of capital.

(iii) *Trading restrictions*

The total number of shares which a company is authorized to repurchase on the Stock Exchange is such number of shares which represents up to a maximum of 10% of the existing issued share capital of our Company as of the date of the resolution approving the repurchase. A company may not issue or announce an issue of securities for a period of 30 days immediately following a repurchase (other than an issue of securities pursuant to an exercise of warrants, share options or similar instruments requiring the company to issue securities which were outstanding prior to such repurchase) without the prior approval of the Stock Exchange.

(iv) *Shares to be purchased*

The Listing Rules provide that the shares which are proposed to be purchased by a company must be fully paid up.

(v) *Status of repurchased securities*

The listing of all repurchased securities (whether on the Stock Exchange or otherwise) is automatically cancelled and the relative certificates for those securities must be cancelled and destroyed. Under the laws of the Cayman Islands, a company's repurchased securities are to be treated as cancelled.

(vi) *Suspension of repurchases*

Securities repurchases are prohibited after a price sensitive development has occurred or has been the subject of a decision until such time as the price sensitive information has been publicly announced. In addition, the Stock Exchange reserves the right to prohibit repurchases of securities on the Stock Exchange if a company has breached the Listing Rules.

(vii) *Reporting requirements*

Repurchases of securities on the Stock Exchange or otherwise must be reported to the Stock Exchange not later than 30 minutes before the earlier of the commencement of the morning trading session or any pre-opening session on the following business day. In addition, the company's annual report is required to disclose details regarding repurchases of securities made during the year, including the number of securities repurchased and the aggregate prices paid.

(viii) *Connected persons*

A company is prohibited from knowingly repurchasing securities on the Stock Exchange from a "connected person", that is, a director; chief executive or substantial shareholder of the company or any of its subsidiaries or their associates (as defined in the Listing Rules) and a connected person is prohibited from knowingly selling his securities to the company.

**(b) *Share capital***

The exercise in full of the repurchase mandate, on the basis of 702,057,995 Shares in issue immediately following completion of the Global Offering and the Capitalization Issue (assuming the Over-allotment is not exercised), could accordingly result in up to 70,205,799 Shares being repurchased by our Company during the period prior to the date on which such repurchase mandate expires or terminates.

**(c) *General information relevant to the repurchase mandate***

- (i) Our Directors believe that it is in the best interests of our Company and our shareholders to have a general authority from shareholders to enable our Directors to repurchase Shares in the market. Repurchases of shares will only be made when our Directors believe that such repurchases will benefit our Company and our shareholders. Such repurchases may, depending on market conditions and funding arrangements at the time, lead to an enhancement of our net value and our assets and/or earnings per Share.
- (ii) There might be a material adverse impact on our working capital or gearing position (as compared with the position disclosed in this prospectus) in the event that the buyback mandate is exercised in full. However, our Directors do not propose to exercise the repurchase mandate to such extent as would, in the circumstances, have a material adverse effect on our working capital requirements or on such gearing levels that our Directors consider appropriate from time to time.
- (iii) None of our Directors or, to the best of their knowledge having made all reasonable enquiries, any of their respective associates, have any present intention to sell any Shares to our Company if the repurchase mandate is exercised.
- (iv) Our Directors have undertaken to the Stock Exchange that, so far as the same may be applicable, they will exercise the repurchase mandate only in accordance with the Listing Rules, the Articles and the applicable laws of the Cayman Islands. We shall procure the broker who effects the repurchase of securities to disclose to the Stock Exchange such information in relation to the purchase as the Stock Exchange may request.
- (v) If as a result of a repurchase of securities a shareholder's proportionate interest in the voting rights of our Company increases, such increase will be treated as an acquisition for the purposes of the Takeovers Code. Accordingly, a shareholder (or a group of shareholders acting in concert, as defined in the Takeovers Code) could obtain or consolidate control of our Company and become obliged to make a mandatory offer in accordance with Rule 26 of the Takeovers Code. Except as aforesaid, our Directors are not aware of any consequences that may arise under the Takeovers Code as a result of a repurchase pursuant to the repurchase mandate.
- (vi) Any repurchase of Shares which results in the amount of Shares held by the public being reduced to less than 25% could only be implemented with the agreement of the Stock Exchange to waive the requirement regarding the public shareholding referred to above. Except in extraordinary circumstances, a waiver of this provision would not normally be given by the Stock Exchange.
- (vii) No connected person (as defined in the Listing Rules) has notified us that he has any present intention to sell Shares to our Company, nor has any connected person undertaken not to do so, if the repurchase mandate is exercised.

## 2. FURTHER INFORMATION ABOUT THE BUSINESS





### A. Summary of material contracts

The following contracts (not being contracts in the ordinary course of business) have been entered into by us within the two years preceding the date of this prospectus and are, or may be, material:

- (a) a termination agreement dated November 27, 2009 among our Company, MOBI Shenzhen, SB Asia, Cisco, Manitou, Fangyi Holdings, Junyi Holdings, Hu Xiang, Wang Guoying and Shao Zhiguo, for terminating the shareholders' agreement entered into on December 19, 2002 by the shareholders of our Company at the time together with our Company, MOBI Shenzhen and SB Asia;
- (b) a deed of indemnity dated November 27, 2009 made by the Beneficial Owners and Fangyi Holdings in favour of our Group (for ourselves and as trustee for our subsidiaries), pursuant to which the Beneficial Owners and Fangyi Holdings have jointly and severally agreed to indemnify our Group against certain taxes and other indemnities; and
- (c) the Hong Kong Underwriting Agreement.

### B. Our intellectual property rights





- (a) As of the Latest Practicable Date, we were the registered owner of the following trademarks:

Trademark	Place of Registration	Class	Registration Number	Registration Date	Expiry Date
 摩比	PRC	9 (Note 1)	3092830	May 14, 2003	May 13, 2013
	PRC	9	3891440	May 28, 2006	May 27, 2016
摩比天线	PRC	9	38913441	February 21, 2006	February 20, 2016
摩比	PRC	9	4913681	September 7, 2008	September 6, 2018
MOBI	PRC	9	4913682	December 14, 2009	December 13, 2018
	PRC	9	5073259	March 21, 2009	March 20, 2019
 摩比	Hong Kong	9 (Note 2)	300880029	May 29, 2007	May 28, 2017

Note 1: Antennas; electronic signal transmitters, programme-controlled telephone switches, electric coupling equipment, ceramic wave filters, magnetic materials and components, anti-radio interference equipment (electronic), internal communications devices, wave carrier equipment, optical communications equipment (end of goods).

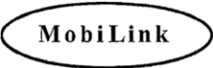
Note 2: Scientific, nautical, surveying, photographic, cinematographic, optical, weighing, measuring, signalling, checking (supervision), life-saving and teaching apparatus and instruments; apparatus and instruments for conducting, switching, transforming, accumulating, regulating or controlling electricity; apparatus for recording, transmission or reproduction of sound or images; magnetic data carriers, recording discs; automatic vending machines and mechanisms for coin-operated apparatus; cash registers; calculating machines, data processing equipment and computers; fire-extinguishing apparatus.

- (b) As of the Latest Practicable Date, we had applied for the registration of the following trademarks:

Trademark	Place of Application	Class	Application Date	Application Number
	HK	9	November 10, 2009	301471987
	PRC	9	January 12, 2007	5841172
	PRC	9	January 3, 2007	5940553
	PRC	9	January 3, 2007	5940554
	PRC	9	January 3, 2007	5940555

- (c) As of the Latest Practicable Date, we have been granted the following patents in the PRC:

Type of Patent	Patent Description	Patent Number	Registration Date	Expiry Date
1. Design Patent	GPS天綫 (GPS antenna)	ZL 2005 3 0072037.7	August 30, 2006	October 12, 2015
2. Design Patent	智能平面陣天綫 (Intelligent planar array antenna)	ZL 2005 3 0074314.8	August 30, 2006	October 25, 2015
3. Design Patent	定向天綫 (Directional antenna)	ZL 2005 3 0074313.3	December 20, 2006	October 25, 2015
4. Design Patent	雙工器腔體 (Duplexer cavity)	ZL 2005 3 0072038.1	January 17, 2007	October 12, 2015
5. Design Patent	天綫包裝盒 (The package of antenna)	ZL 2004 3 0053768.2	February 9, 2005	May 12, 2014
6. Design Patent	短背射天綫(二) (Short back radio antenna (2))	ZL 2004 3 0053769.7	December 15, 2004	May 12, 2014
7. Design Patent	移動通信基站天綫(四) (Mobile communications base station antenna (4))	ZL 2004 3 0043793.2	February 9, 2005	June 30, 2014
8. Design Patent	移動通信基站天綫(五) (Mobile communications base station antenna (5))	ZL 2004 3 0043792.8	August 10, 2005	June 30, 2014
9. Design Patent	短背射天綫(一) (Short back radio antenna (1))	ZL 2004 3 0053770.X	December 22, 2004	May 12, 2014
10. Design Patent	全向天綫 (Omni antenna)	ZL 2004 3 0044336.5	March 2, 2005	July 9, 2014
11. Design Patent	短背射天綫(二) (Short back radio antenna (2))	ZL 2004 3 0053772.9	December 15, 2004	May 12, 2014
12. Design Patent	智能圓陣天綫 (Intelligent circular array antenna)	ZL 2004 3 0093983.5	August 10, 2005	November 26, 2014
13. Design Patent	移動通信基站天綫(二) (Mobile communications base station antenna (2))	ZL 2004 3 0043146.1	May 18, 2005	June 17, 2014

	Type of Patent	Patent Description	Patent Number	Registration Date	Expiry Date
14.	Design Patent	移動通信基站天線(一) (Mobile communications base station antenna (1))	ZL 2004 3 0053771.4	May 18, 2005	May 12, 2014
15.	Design Patent	全向天線 (Omni antenna)	ZL 2004 3 0043790.9	May 18, 2005	June 30, 2014
16.	Design Patent	移動通信基站天線(三) (Mobile communications base station antenna (3))	ZL 2004 3 0043791.3	February 9, 2005	June 30, 2014
17.	Design Patent	基站天線(寬頻基站定向天線) (Base station antenna (wideband directional base station antenna))	ZL 2007 3 0131645.X	February 6, 2008	February 25, 2017
18.	Design Patent	吸頂天線外罩 (Ceiling antenna cover)	ZL 2007 3 0131646.4	January 2, 2008	February 25, 2017
19.	Design Patent	移動基站天線 (Mobile base station antenna)	ZL 2007 3 0132953.4	May 7, 2008	April 16, 2017
20.	Design Patent	天線(低風阻智慧線陣) (Antenna (low-drag smart antenna array))	ZL 2008 3 0106493.2	May 6, 2009	April 20, 2018
21.	Utility Model Patent	一種PHS幹線放大器電路結構 (A PHS trunk amplifier circuit)	ZL 2005 2 0121461.0	January 24, 2007	December 31, 2015
22.	Utility Model Patent	一種驅動裝置 (A device driver)	ZL 2005 2 0119876.4	January 24, 2007	December 1, 2015
23.	Utility Model Patent	基站電調天線移相器 (Base station antenna — emphasize the Phase Shifter)	ZL 2005 2 0063505.9	January 24, 2007	August 18, 2015
24.	Utility Model Patent	一種雙極化智能平面陣定向天線 (An intelligent dual-polarized plane array of directional antennas)	ZL 2005 2 0060135.3	January 24, 2007	June 24, 2015
25.	Utility Model Patent	三頻段信號合路器 (A three-band signal for the road)	ZL 2004 2 0102897.0	February 15, 2006	December 17, 2014
26.	Utility Model Patent	一種交叉耦合微調裝置 (Fine-tuning cross-coupled devices)	ZL 2005 2 0059424.1	August 30, 2006	June 1, 2015
27.	Utility Model Patent	一種弧形陣列天線 (A camber array of antenna)	ZL 2006 2 0015337.0	November 7, 2007	October 20, 2016
28.	Utility Model Patent	用於腔體濾波器、雙工器、合路器的密封結構 (Sealing structures for cavity filters, duplexers and combiners)	ZL 2005 2 0064932.9	October 25, 2006	September 21, 2015
29.	Utility Model Patent	一種雙工器、合路器安裝裝置 (An installation device for duplexers and combiners)	ZL 2005 2 0058055.4	October 11, 2006	May 2, 2015
30.	Utility Model Patent	一種延伸低噪聲放大器輸出信號的接口電路裝置 (An extension of the low noise amplifier output signal interface circuit installations)	ZL 2005 2 0067938.1	December 13, 2006	November 28, 2015
31.	Utility Model Patent	一種雙工器 (A diplexer)	ZL 2005 2 0060817.4	August 9, 2006	June 28, 2015
32.	Utility Model Patent	一種智能天線陣 (An intelligent array antenna)	ZL 2005 2 0059860.9	August 9, 2006	June 9, 2015

	Type of Patent	Patent Description	Patent Number	Registration Date	Expiry Date
33.	Utility Model Patent	一種雙層微帶貼片平面陣定向天線 (A double-decker plane microstrip patch array of directional antennas)	ZL 2005 2 0053411.3	March 29, 2006	January 17, 2015
34.	Utility Model Patent	一種基站天線安裝夾具 (The installation of a base station antenna fixture)	ZL 2005 2 0054467.0	June 21, 2006	January 28, 2015
35.	Utility Model Patent	同軸腔體諧振器間耦合結構 (Coaxial resonator cavity coupling structure)	ZL 2006 2 0016814.5	September 12, 2007	June 29, 2016
36.	Utility Model Patent	WCDMA塔頂放大器 (W-CDMA tower amplifiers)	ZL 2006 2 0017777.X	October 3, 2007	August 16, 2016
37.	Utility Model Patent	一種寬帶帶線帶通濾波器 (Broadband line with a band-pass filter)	ZL 2006 2 0014660.6	October 3, 2007	September 11, 2016
38.	Utility Model Patent	寬頻吸頂天線 (Broadband IC antenna)	ZL 2005 2 0062296.6	October 25, 2006	July 29, 2015
39.	Utility Model Patent	一種定向天線 (A directional antenna)	ZL 2005 2 0063465.8	October 25, 2006	August 17, 2015
40.	Utility Model Patent	雙頻雙極化天線 (Dual dual-polarized antenna)	ZL 2005 2 0064686.7	December 6, 2006	September 14, 2015
41.	Utility Model Patent	一種基站天線安裝夾具 (The installation of a base station antenna fixture)	ZL 2005 2 0057842.7	August 9, 2006	April 27, 2015
42.	Utility Model Patent	一種雙極化拋物面天線饋源 (A dual-polarization parabolic antenna feed)	ZL 2004 2 0102902.8	February 15, 2006	December 24, 2014
43.	Utility Model Patent	一種高隔離空氣微帶耦合饋電貼片天線 (A high isolation air micro-matching feeder patch antenna)	ZL 2004 2 0103444.X	February 15, 2006	December 22, 2014
44.	Utility Model Patent	一種具有多單元雙工器的射頻裝置 (A multi-unit duplex RF device)	ZL 2003 2 0117927.0	December 15, 2004	November 8, 2013
45.	Utility Model Patent	一種雙向耦合器裝置 (A two-way coupler device)	ZL 2004 2 0046755.7	July 27, 2005	June 2, 2014
46.	Utility Model Patent	一種基站天線用同軸連接器 (A base station antenna coaxial connectors)	ZL 2004 2 0094290.2	November 9, 2005	October 21, 2014
47.	Utility Model Patent	一種用於固定空氣微帶線的介質支撐 (A media support for fixing air microstrip line)	ZL 2004 2 0094291.7	October 12, 2005	October 21, 2014
48.	Utility Model Patent	一種空氣微帶耦合饋電貼片天線 (An air micro-matching feeder patch antenna)	ZL 2004 2 0046114.1	June 1, 2005	May 18, 2014
49.	Utility Model Patent	波導印刷天線 (Printing waveguide antenna)	ZL 2004 2 0083293.6	September 7, 2005	August 23, 2014
50.	Utility Model Patent	一種平面陣定向天線 (A plane array of directional antennas)	ZL 2004 2 0045698.0	May 11, 2005	May 9, 2014
51.	Utility Model Patent	氣動塗膠裝置 (Pneumatic glues devices)	ZL 2003 2 0128844.1	January 5, 2005	December 31, 2013
52.	Utility Model Patent	一種雙頻型全向天線 (A dual-band omni-directional antennas)	ZL 2004 2 0094588.3	November 2, 2005	October 27, 2014

	Type of Patent	Patent Description	Patent Number	Registration Date	Expiry Date
53.	Utility Model Patent	一種單極化定向板狀天線饋電結構 (A unipolar directional antenna feed slab structure)	ZL 2004 2 0083284.7	September 7, 2005	August 23, 2014
54.	Utility Model Patent	一種電纜剝皮機 (A cable skinning machine)	ZL 2003 2 0128822.5	February 9, 2005	December 31, 2013
55.	Utility Model Patent	天線安裝夾具 (Fixture antenna installation)	ZL 2004 2 0089607.3	October 26, 2005	September 2, 2014
56.	Utility Model Patent	雙頻段信號合路器 (Dual-band signal with a road)	ZL 2004 2 0045296.0	August 17, 2005	April 25, 2014
57.	Utility Model Patent	窄帶射頻前端合路器 (Narrowband RF device front-end combiner)	ZL 2004 2 0014548.3	January 5, 2005	January 1, 2014
58.	Utility Model Patent	GSM/CDMA 共天饋系統基站合路器 (GSM/CDMA shared antenna and feeder system base station combiner)	ZL 2004 2 0088778.4	October 5, 2005	September 22, 2014
59.	Utility Model Patent	一種多扇區天線 (A multi-sector antenna)	ZL 2005 2 0120488.8	February 14, 2007	December 10, 2015
60.	Utility Model Patent	一種多扇區天線 (A multi-sector antenna)	ZL 2005 2 0120490.5	February 14, 2007	December 10, 2015
61.	Utility Model Patent	一種射頻裝置 (A radiofrequency device)	ZL 2005 2 0066563.7	March 21, 2007	November 4, 2015
62.	Utility Model Patent	雙極化天線 (Dual-Polarized Antenna)	ZL 2005 2 0064410.9	March 14, 2007	September 9, 2015
63.	Utility Model Patent	一種帶線功率合路器 (A power combiner)	ZL 2006 2 0014161.7	July 11, 2007	May 31, 2016
64.	Utility Model Patent	濾波器加強耦合結構 (Filter enhance coupling structure)	ZL 2006 2 0056123.8	March 14, 2007	March 7, 2016
65.	Utility Model Patent	微帶功率分配器 (Microstrip power splitter)	ZL 2005 2 0121546.9	February 14, 2007	December 28, 2015
66.	Utility Model Patent	基站電調天線的移相器 (Base station electric adjusted shifter)	ZL 2006 2 0053705.0	February 28, 2007	January 13, 2016
67.	Utility Model Patent	一種組合交叉耦合裝置 (A combination of cross-coupled devices)	ZL 2006 2 0013312.7	March 21, 2007	March 29, 2016
68.	Utility Model Patent	帶結環行器 (Taped circular device)	ZL 2006 2 0013826.2	May 23, 2007	April 27, 2016
69.	Utility Model Patent	一種智能直線陣天線 (A linear array of intelligent antennas)	ZL 2006 2 0017528.0	August 15, 2007	June 20, 2016
70.	Utility Model Patent	寬頻定向天線 (Broadband directional antenna)	ZL 2006 2 0017525.7	July 4, 2007	June 20, 2016
71.	Utility Model Patent	基站天線調整固定夾具及應用該夾具的天線 (Fixed base station antenna adjustment application of the fixture and the fixture antenna)	ZL 2005 2 0067318.8	July 25, 2007	November 9, 2015
72.	Utility Model Patent	低噪聲放大器監控告警裝置 (Low noise amplifier alarm monitoring device)	ZL 2006 2 0145433.7	December 5, 2007	December 29, 2016
73.	Utility Model Patent	一種環行隔離器 (A ring isolators)	ZL 2006 2 0145340.4	December 5, 2007	December 27, 2016

	Type of Patent	Patent Description	Patent Number	Registration Date	Expiry Date
74.	Utility Model Patent	同軸腔體諧振器間的感性耦合結構及採用該結構的濾波器 (Coaxial resonator cavity inductive coupling between the structure and use of the structure of the filter)	ZL 2006 2 0145488.8	December 26, 2007	December 30, 2016
75.	Utility Model Patent	防雷型射頻模塊 (Lightning RF Module)	ZL 2006 2 0145489.2	December 26, 2007	December 30, 2016
76.	Utility Model Patent	射頻控制電路 (RF control circuits)	ZL 2006 2 0016573.4	November 21, 2007	December 18, 2016
77.	Utility Model Patent	濾波器和公共端口之間的耦合結構及採用該結構的雙工器 (Matching structure of filters and public ports and duplexers applying that structure)	ZL 2006 2 0016430.3	December 5, 2007	December 12, 2016
78.	Utility Model Patent	一種移動終端外置天綫 (An external antenna for mobile terminals)	ZL 2006 2 0015820.9	October 31, 2007	November 16, 2016
79.	Utility Model Patent	一種通信接口信號傳輸電路 (A communication interface circuit signal transmission)	ZL 2006 2 0016518.5	January 2, 2008	December 14, 2016
80.	Utility Model Patent	同軸腔體諧振器間的耦合結構 (Coaxial resonator cavity between the coupling structure)	ZL 2006 2 0016616.9	January 2, 2008	December 19, 2016
81.	Utility Model Patent	一種寬頻雙極化天綫振子 (A stream of broadband dual-polarized antenna structure)	ZL 2006 2 0145421.4	January 23, 2008	December 28, 2016
82.	Utility Model Patent	一種板狀基站天綫屏蔽罩 (A slab base station antenna shield)	ZL 2006 2 0145418.2	March 5, 2008	December 28, 2016
83.	Utility Model Patent	一種偏置T型裝置 (An offset T-shape device)	ZL 2006 2 0145487.3	January 2, 2008	December 29, 2016
84.	Utility Model Patent	一種駐波檢測耦合結構 (A standing wave detection coupling structure)	ZL 2007 2 0121011.0	June 18, 2008	June 17, 2017
85.	Utility Model Patent	一種雙頻雙極化電調天綫 (A dual-dual-polarized electronic adjustment antenna)	ZL 2007 2 0121185.7	May 14, 2008	July 3, 2017
86.	Utility Model Patent	一種直流電流檢測告警電路 (A DC detection alarm circuit)	ZL 2007 2 0121518.6	May 14, 2008	July 8, 2017
87.	Utility Model Patent	一種線陣智能天綫 (A linear array of intelligent antenna)	ZL 2007 2 0172400.6	October 8, 2008	October 10, 2017
88.	Utility Model Patent	板狀天綫裝配翻轉工裝 (Rotary configuration of slab antenna assembly)	ZL 2007 2 0119906.0	April 2, 2008	April 25, 2017
89.	Utility Model Patent	合路器 (Combiner)	ZL 2007 2 0118905.4	February 6, 2008	March 11, 2017
90.	Utility Model Patent	一種新型耦合結構 (A new type of coupling structure)	ZL 2007 2 0118824.4	February 20, 2008	March 5, 2017
91.	Utility Model Patent	一種同軸腔體諧振器間的耦合結構 (A type of coupling structure in coaxial cavity resonator)	ZL 2007 2 0170722.7	September 17, 2008	November 11, 2017

	Type of Patent	Patent Description	Patent Number	Registration Date	Expiry Date
92.	Utility Model Patent	一種耦合器耦合結構 (A type of coupling structure of coupler)	ZL 2007 2 0 170489.2	September 17, 2008	November 4, 2017
93.	Utility Model Patent	一種寬頻雙極化天線振子 (A stream of broadband dual-polarized antenna structure)	ZL 2007 2 0170443.0	September 10, 2008	October 30, 2017
94.	Utility Model Patent	寬頻雙極化天線振子 (A wideband dual-polarized radiation element)	ZL 2007 2 0170876.6	September 17, 2008	November 15, 2017
95.	Utility Model Patent	一種天線內置合路器 (A built-in antenna combiner)	ZL 2008 2 0091865.3	December 3, 2008	January 22, 2018
96.	Utility Model Patent	一種圓極化天線及射頻識別裝置 (A circularly-polarized antenna and radiation identification device)	ZL 2008 2 0093743.8	February 4, 2009	April 29, 2018
97.	Utility Model Patent	一種小間距陣列天線 (A small pitch array antenna)	ZL 2008 2 0093900.5	February 25, 2009	May 6, 2018
98.	Utility Model Patent	一種微帶線功率合路器 (A microstrip power combiner)	ZL 2008 2 0093925.5	March 11, 2009	May 8, 2018
99.	Utility Model Patent	一種射頻前端模組密封結構 (An RF front end module sealing structure)	ZL 2008 2 0093926.X	March 11, 2009	May 8, 2018
100.	Utility Model Patent	一種WIMAX雙極化基站定向天線 (A dual-polarized WiMAX Direction Base Station Antenna)	ZL 2008 2 0093934.4	May 20, 2009	May 11, 2018
101.	Utility Model Patent	一種多工器公共端口 (A multiplexer Public Port)	ZL 2008 2 0093936.3	May 20, 2009	May 11, 2018
102.	Utility Model Patent	一種寬頻雙極化電調天線 (A wideband dual-polarized RET antenna)	ZL 2008 2 0093937.8	March 11, 2009	May 11, 2018
103.	Utility Model Patent	一種電調天線傳動機構 (A transmission mechanism of RET Antenna)	ZL 2008 2 0094752.9	March 11, 2009	May 13, 2018
104.	Utility Model Patent	一種卡扣式固定結構 (A snap-in fixed structures)	ZL 2008 2 0094753.3	March 11, 2009	May 13, 2018
105.	Utility Model Patent	一種定向天線夾具 (A directional antenna fixture)	ZL 2008 2 0094141.4	February 25, 2009	May 20, 2018
106.	Utility Model Patent	WIFI一體化覆蓋天線 (An integrated covered WIFI antenna)	ZL 2008 2 0094085.4	February 25, 2009	May 27, 2018
107.	Utility Model Patent	一種寬頻雙極化天線陣子 (A wideband dual-polarized radiation element)	ZL 2008 2 0094084.X	February 25, 2009	May 27, 2018
108.	Utility Model Patent	一種射頻放大器及移動通信接收機 (An RF amplifier and mobile communications receiver)	ZL 2008 2 0094262.9	March 4, 2009	May 29, 2018
109.	Utility Model Patent	一種天線振子元件及天線振子的連接裝置 (A radiation element and the element connector)	ZL 2008 2 0094897.9	May 20, 2009	June 19, 2018
110.	Utility Model Patent	同軸腔體諧振器及同軸腔體濾波器 (A coaxial cavity resonator and coaxial Cavity Filter)	ZL 2008 2 0095130.8	April 15, 2009	June 29, 2018

	Type of Patent	Patent Description	Patent Number	Registration Date	Expiry Date
111.	Utility Model Patent	低通濾波器 (A low-pass filter)	ZL 2008 2 0095131.2	April 15, 2009	June 29, 2018
112.	Utility Model Patent	一種微帶傳輸線結構 (A microstrip transmission line structure)	ZL 2008 2 0095614.2	May 20, 2009	July 13, 2018
113.	Utility Model Patent	一種同軸電纜的壓接裝置 (A coaxial cable crimping device)	ZL 2008 2 0095570.3	April 15, 2009	July 15, 2018
114.	Utility Model Patent	一種智能天線校準電路 (A smart antenna calibration circuit)	ZL 2008 2 0095749.9	June 10, 2009	July 22, 2018
115.	Utility Model Patent	寬頻共軸雙頻雙極化電調天線 (A wideband co-axial dual-band dual-polarized antenna)	ZL 2008 2 0095804.4	July 22, 2009	July 22, 2018
116.	Utility Model Patent	一種導向裝置 (A guiding device)	ZL 2008 2 0146938.4	July 15, 2009	August 25, 2018
117.	Utility Model Patent <sup>×</sup>	一種內置式天線與塔放的一體化結構 (A kind of built-in antenna and tower amplifier integrated structure)	ZL 2008 2 0095333.7	April 15, 2009	July 7, 2018
118.	Utility Model Patent	一種電調天線移相結構 (A kind of phase shifting structure in RET antenna)	ZL200820212920.X	July 29, 2009	October 6, 2018
119.	Utility Model Patent	一種隔離器 (A kind of isolator)	ZL200820212839.1	August 19, 2009	October 26, 2018
120.	Utility Model Patent	駐波檢測裝置結構 (A standing wave detection device structure)	ZL200820213770.4	September 16, 2009	November 25, 2018
121.	Utility Model Patent	無線通信設備室外壁掛式安裝結構 (A wireless communications equipment outdoor wall-mounted structure)	ZL200820235692.8	October 7, 2009	December 25, 2018
122.	Utility Model Patent	一種失配負載裝置及雙工器 (A mismatch load device and duplexer)	ZL200820235565.8	October 14, 2009	December 25, 2018

<sup>×</sup> Joint ownership with 中國移動通信研究院

- (d) As of the Latest Practicable Date, we had applied for the registration of the following patents in the PRC:

	Type of Patent	Patent Description	Application Date	Application Number
1.	Utility Model Patent	射頻同軸電纜 (An RF coaxial cable)	October 14, 2009	200920205907.6
2.	Utility Model Patent	一種連續可調的移相器 (A continuously adjustable phase shift)	January 16, 2009	200920129521.1
3.	Utility Model Patent	一種電調天線傳動機構 (A transmission mechanism in RET antenna)	April 13, 2009	200920130761.3

	Type of Patent	Patent Description	Application Date	Application Number
4.	Utility Model Patent	腔體濾波器 (A cavity filter)	April 16, 2009	200920130771.7
5.	Utility Model Patent	一種板材拼接的天線外罩 (A panel splicing radome)	April 17, 2009	200920130852.7
6.	Utility Model Patent	同軸腔體諧振器容性交叉耦合結構 (A coaxial cavity resonator capacitive cross-coupling structure)	May 6, 2009	200920131416.1
7.	Utility Model Patent	帶信號端口的無線通信裝置 (A wireless communication device with signal port)	May 6, 2009	200920131417.6
8.	Utility Model Patent	一種室外用模組化授時型GPS接收機 (A modular outdoor GPS timing receiver)	May 7, 2009	200920131708.5
9.	Utility Model Patent	濺散板饋源及微波天線 (A splashplate feed and microwave antenna)	May 27, 2009	200920132251.X
10.	Utility Model Patent	天線介質組件及雙極化陣列天線輻射單元 (An antenna media components and dual-polarized array antenna radiating element)	June 30, 2009	200920133411.2
11.	Utility Model Patent	一種射頻同軸電纜 (A RF coaxial cable)	April 22, 2009	200920131052.7
12.	Utility Model Patent	一種寬頻校準網路 (A wideband calibration network)	April 28, 2009	200920131117.8
13.	Utility Model Patent	一種一體化集束天線結構 (An integrative clustered antenna structure)	May 26, 2009	200920132231.2
14.	Utility Model Patent	一種定向耦合器和信號檢測系統 (A directional coupler and signal detection system)	June 22, 2009	200920133206.6
15.	Utility Model Patent	一種天線結構 (A kind of antenna structure)	June 25, 2009	200920133705.5
16.	Utility Model Patent	寬頻微帶三功分器 (A wideband microstrip 3db splitter)	July 10, 2009	200920133810.9
17.	Utility Model Patent	寬頻微帶功分器 (A wideband microstrip splitter)	July 10, 2009	200920133811.3
18.	Invention Patent	一種駐波比測量方法及裝置 (A standing-wave ratio test method and device)	March 13, 2009	200910105989.1
19.	Invention Patent	一種寬頻雙極化天線陣子結構 (A stream of broadband dual-polarized antenna)	December 1, 2006	200610157272.8

	Type of Patent	Patent Description	Application Date	Application Number
20.	Invention Patent	智能天線的校準網絡 (A smart antenna calibration network)	March 9, 2006	200610034285.6
21.	Invention Patent	低噪聲放大器模塊裝置 (A low noise amplifier module device)	July 15, 2005	200510036079.4
22.	Invention Patent	雙極化加載天線輻射單元 (A dual-polarized antenna radiation load modules)	April 27, 2005	200510034456.0
23.	Invention Patent	一種TD-SCDMA杆線放大器獲取轉換點位置的方法 (A TD-SCDMA trunk amplifier access the location of conversion methods)	June 1, 2007 <sup>(1)</sup>	200710073666.X
24.	Invention Patent	一種駐波檢測裝置及方法 (A standing wave detection device and method)	September 28, 2007	200710123724.5
25.	Invention Patent	一種智能天線校準網絡及其校準方法 (A smart antenna calibration network and its calibration method)	June 30, 2008	200810068090.2
26.	Invention Patent	一種腔體濾波器和雙工器 (A cavity filter and diplexer)	June 30, 2008	200810068093.6
27.	Invention Patent	一種低雜訊放大器的駐波比調試方法及系統 (A standing wave debugging method and system for low-noise amplifier)	July 7, 2008	200810068338.5
28.	Invention Patent	一種防雷保護電路及天線設備 (A lightning protection circuitry and antenna equipment)	October 27, 2008	200810217084.9
29.	Invention Patent	可變失配負載裝置、射頻裝置以及駐波比和相位調節方法 (A variable mismatch load device, RF device and standing wave ratio and phase debugging method)	December 30, 2008	200810241757.4
30.	Invention Patent	一種低通濾波器、射頻濾波器和雙工器 (A low-pass filter, RF Filter and diplexer)	December 31, 2008	200810242145.7
31.	Invention Patent	一種寬頻雙極化天線輻射元結構 (A wideband dual-polarized antenna radiation element structure)	March 10, 2009	200910105955.2
32.	Invention Patent	一種雙極化饋源裝置及天線 (A dual-polarized feed device and antenna)	May 22, 2009	200910107391.6

	Type of Patent	Patent Description	Application Date	Application Number
33.	Invention Patent	寬頻微帶四功分器 (A wideband microstrip 4 Splitter)	July 10, 2009	200910108727.0
34.	Design Patent	GPS 有源天線 (A GPS Active Antenna)	December 31, 2008	200830254154.9
35.	Utility Model Patent	帶相位檢測功能的合路器 (A combiner with phase detection function)	August 11, 2009	200920134718.4
36.	Utility Model Patent	一種駐波可變的大功率失配負載 (A standing wave variable high power load)	August 12, 2009	200920134773.3
37.	Utility Model Patent	可調增益的低噪音放大器 (An adjustable gain low-noise amplifier)		200920134936.8
38.	Utility Model Patent	一種雙級化輻射單元 <sup>2</sup> (A dual-polarized radiation element )		200820123606.4

<sup>1</sup> Joint application with 中國移動通信研究院

<sup>2</sup> Joint application with 中國移動通信集團公司

*Note:*

(1) Preliminary examination date

- (e) As of the Latest Practicable Date, we were the registered owner of the following domain name(s):

Domain Name	Period of Registration (DD-MM-YYYY)
www.mobi-antenna.com	22-12-2005 to 22-12-2010
www.mobile-antenna.com	19-10-2001 to 19-10-2010

The contents of the website(s), registered or licensed, do not form part of this prospectus.

Except as aforesaid, there are no other trade or service marks, patents, other intellectual or industrial property rights which are or may be material in relation to our Group's business.

**3. FURTHER INFORMATION ABOUT THE GROUP'S ENTERPRISES IN THE PRC**

Brief particulars of the operating subsidiaries of our Company set up in the PRC are set out below:

**(1) *MOBI Shenzhen***

Names:	摩比天線技術(深圳)有限公司 (MOBI Antenna Technologies (Shenzhen) Co., Ltd.)
Date and place of establishment:	August 12, 1999; PRC
Nature:	wholly foreign-owned enterprise
Registered office:	MOBI Building, Langshan First Road, North Area, High And New Zone, Nanshan District, Guangdong Province, Shenzhen, PRC
Registered Owner:	Our Company
Scope of business:	Research and development, manufacture and trading of mobile communication system antennas, RF devices, RF modules, RF (sub) systems, RF cables, various ancillary products for mobile base stations, small integrated systems for communication and after sales installation services
Registered capital:	RMB30,000,000 (fully paid up)
Total investment:	RMB52,500,000
Attributable interest to our Group:	100%
Term of operation:	August 12, 1999 to January 21, 2033
Legal Representative:	Hu Xiang

**(2) *MOBI Jian***

Names:	摩比通訊技術(吉安)有限公司 (MOBI Telecommunication Technologies (Jian) Co., Ltd.)
Date and place of establishment:	May 23, 2006; PRC
Nature:	limited liability company (invested solely by foreign legal entity)
Registered Owner:	Our Company
Registered office:	Industrial Park, Jizhou District, Jian, Jiangxi Province, PRC

Scope of business:	Manufacture and trading of mobile communication system antennas, RF devices, RF modules, RF (sub) systems, RF cables, various ancillary products for mobile base stations (any item above requiring approval shall be operated with a permit, except for those with special provisions of the state)
Registered capital:	RMB3,000,000 (fully paid up)
Total investment:	RMB3,000,000
Attributable interest to our Group:	100%
Term of operation:	May 23, 2006 to May 22, 2016
Legal Representative:	Hu Xiang

(3) *MOBI Xian*

Names:	摩比科技(西安)有限公司 (MOBI Technologies (XI'AN) Co., Ltd.)
Date and place of establishment:	April 29, 2008; PRC
Nature:	limited liability company (invested by foreign-invested enterprise)
Registered Owner:	MOBI Shenzhen
Registered office:	6 Shuoshi Road, New Type Industrial Park, High and New Zone, Xian, Shaanxi Province, PRC
Scope of business:	Research and development, manufacture and trading of mobile communication system antennas, RF devices, RF modules, RF (sub) systems, RF cables, various ancillary products for mobile base stations, small integrated systems for communication and after sales installation services (scope of business above excludes products which require administrative approval under laws and regulations)
Registered capital:	RMB120,000,000 (of which RMB24,000,000 has been paid up)
Total investment:	RMB200,000,000
Attributable interest to our Group:	100%
Term of operation:	April 29, 2008 to April 28, 2023
Legal Representative:	Hu Xiang

#### 4. FURTHER INFORMATION ABOUT DIRECTORS, MANAGEMENT AND STAFF

##### A. Particulars of Directors' service agreements

Each of the executive Directors and non-executive Directors has entered into a service agreement with our Company commencing from the Listing Date for a term of three years, respectively.

Each of the executive Directors is entitled to a director's fee and a basic salary and the non-executive Directors is entitled to a director's fee. The current basic annual remunerations (excluding any discretionary bonus which may be paid) payable by our Group to the executive Directors and non-executive Directors are set out below. The executive Directors are entitled to participate in our Group's social insurance and accident insurance. All the Directors are entitled to directors' and officers' liability insurance schemes.

	<i>RMB</i>
<b>Executive Director</b>	
Hu Xiang	794,540
Wang Guoying	720,540
	<i>HK\$</i>
<b>Non-executive Director</b>	
Qu Deqian	100,000
Xing Qibin	100,000
Yan Andrew Y.	100,000
Yang Dong	100,000

Each of the independent non-executive Director has entered into a letter of appointment with our Company for a term of three years commencing from the Listing Date (except for Li Tianshu whose engagement with us commenced on July 1, 2007) and renewable by mutual agreement on annual basis. The current basic annual remuneration payable by our Group to the independent non-executive Directors are as follows:

	<i>HK\$</i>
<b>Independent Non-executive Director</b>	
Li Tianshu	180,000
Zhang Han	160,000
Bao Fan	160,000

##### B. Directors' remuneration

The aggregate remunerations paid to the Directors by our Group in respect of the financial year ended December 31, 2008 were approximately RMB1,495,000. The aggregate remunerations and benefits in kind which the Directors are entitled to receive for the financial year ended December 31, 2009 are estimated to be approximately RMB1,650,000, excluding any discretionary bonuses which may be paid to the Directors.

##### C. Personal guarantees

Save and except as disclosed in Appendix I to this prospectus, no executive Directors or related parties have provided guarantees for debts and liabilities due by any members of our Group.

**D. Interests of Directors and chief executive in our share capital**

Immediately following completion of the Global Offering, the Capitalization Issue and conversion of the Series A Preferred Shares into Shares (without taking into account any Shares that may be issued and allotted pursuant to the exercise of the Over-allotment Option or options granted under Pre-IPO Stock Incentive Plans or may be granted under the Share Option Scheme or Shares that may be taken by a person under the Global Offering which would affect disclosure in this section), the interests and short positions of the Directors and chief executive of our Company in the Shares, underlying Shares and debentures of our Company or any of its associated corporations (within the meaning of Part XV of the SFO), which, once the Shares are listed on the Stock Exchange, will have to be notified to our Company and the Stock Exchange pursuant to Divisions 7 and 8 of Part XV of the SFO (including interests and short positions which they have taken or deemed to have under such provisions of the SFO), or will be required, pursuant to section 352 of the SFO, to be entered in the register referred to therein, or will be required to be notified to our Company and the Stock Exchange pursuant to the Model Code for Securities Transactions by Directors of Listed Companies in the Listing Rules, will be as follows:

## (i) Shares

<b>Name of Director</b>	<b>Nature of Interest</b>	<b>Number of Shares<sup>(1)</sup></b>	<b>Approximate percentage of shareholding</b>
Hu Xiang	Personal	23,095,000(L)	3.29
Wang Guoying	Personal	24,734,000(L)	3.52

\_\_\_\_\_  
Note:

(1) The letter “L” denotes long position of the directors in the Shares.

(ii) Shares Underlying the Pre-IPO Options<sup>(1)</sup>

<b>Name of Director</b>	<b>Nature of Interest</b>	<b>Number of Shares Underlying the Pre-IPO Options</b>
Hu Xiang	Personal	4,100,000
Wang Guoying	Personal	1,750,000
Qu Deqian	Personal	600,000
Xing Qibin	Personal	600,000
Yan Andrew Y.	Personal	675,000
Yang Dong	Personal	675,000

\_\_\_\_\_  
Note:

(1) The Pre-IPO Options were granted under the Pre-IPO Stock Incentive Plans. The summary of the terms of the Pre-IPO Stock Incentive Plans and the terms of the Pre-IPO Options granted are set out in the section headed “5. Pre-IPO Options” in this appendix.

**E. Substantial shareholders**

So far as the Directors are aware, information on the persons, not being Directors or the chief executive of our Company, who will have, immediately following completion of the Global Offering, the Capitalization Issue and conversion of the Series A Preferred Shares into Shares (without taking into account Shares that may be issued and allotted pursuant to the exercise of the Over-allotment Option or options granted under Pre-IPO Stock Incentive Plans or may be granted under the Share Option Scheme or Shares that may be taken by a person under the Global Offering which would affect disclosure in this section) an interest or short position in the Shares and underlying Shares of our Company which would fall to be disclosed to our Company and the Stock Exchange under the provisions of Divisions 2 and 3 of Part XV of the SFO or who is, directly or indirectly interested in 10% or more of the nominal value of any class of share capital carrying rights to vote in all circumstances at general meetings of any other member of our Group will be as follows:

Name of Shareholder	Nature of interest	Number of Shares <sup>(1)</sup>	Approximate percentage of shareholding
Fangyi Holdings	Beneficial Owner	209,643,000(L)	29.86
SB Asia	Beneficial Owner	152,999,995(L)	21.79
SB Asia Pacific Partners L.P.	Interest of a controlled corporation <sup>(2)</sup>	152,999,995(L)	21.79
Shao Zhiguo	Beneficial Owner	41,496,500(L)	5.91

*Notes:*

- (1) The letter “L” denotes long position of the shareholders in the Shares.
- (2) These shares are registered in the name of SB Asia, in which SB Asia Pacific Partners L.P. is a general partner. SB Asia Pacific Partners L.P. is deemed to be interested in all the shares in which SB Asia is interested by virtue of the SFO.

**F. Disclaimers**

Except as disclosed in this prospectus:

- (a) none of our Directors or any of the experts referred to in the paragraph headed “Consents of experts” in this Appendix has any direct or indirect interest in the promotion of our Company, or in any assets which have been within the two years immediately preceding the date of this prospectus, acquired or disposed of by or leased to, any member of our Group, or are proposed to be so acquired, disposed of or leased;
- (b) none of our Directors or any of the experts referred to in the paragraph headed “Consents of experts” in this Appendix is materially interested in any contract or arrangement subsisting at the date of this prospectus which is significant in relation to our business;
- (c) none of the experts referred to in the paragraph headed “Consents of experts” in this Appendix has any shareholding in any member of our Group or the right (whether legally enforceable or not) to subscribe for or to nominate persons to subscribe for securities in any member of our Group, save in connection with the Underwriting Agreements, nor is in the employment of an officer of our Company; and
- (d) none of our Directors, any of their associates (as defined in the Listing Rules) or any shareholder of our Company (which to the knowledge of our Directors owns more than 5% of the issued share capital of our Company) has any interest in any of our Group’s five largest suppliers or five largest customers.

## 5. PRE-IPO OPTIONS

### A. Summary of the principal terms of the Pre-IPO Stock Incentive Plans on the Pre-IPO Options:

The principal terms of the 2005 Stock Incentive Plan and the 2003 Stock Incentive Plan respectively approved and adopted by ordinary resolutions of the shareholders of our Company on July 10, 2004 and January 15, 2003 are substantially the same except for the following:

- (i) the effective date of the 2005 Stock Incentive Plan is July 10, 2004 and the effective date of the 2003 Stock Incentive Plan is January 15, 2003;
- (ii) the maximum number of Shares that may be issued pursuant to options qualified as incentive stock options granted under the 2005 Stock Incentive Plan is 2,612,500 Shares (pre-Capitalization Issue) instead of 2,750,000 Shares (pre-Capitalization Issue) under the 2003 Stock Incentive Plan;
- (iii) the maximum number of Shares subject to those options and stock appreciation rights that are granted during any calendar year to any individual under the 2005 Stock Incentive Plan is 200,000 Shares (pre-Capitalization Issue) instead of 700,000 Shares (pre-Capitalization Issue) under the 2003 Stock Incentive Plan;
- (iv) the maximum number of Shares subject to all awards that are granted during any calendar year to any individual under the 2005 Incentive Stock Plan is 200,000 Shares (pre-Capitalization Issue) instead of 700,000 Shares (pre-Capitalization Issue) under the 2003 Stock Incentive Plan;
- (v) the maximum number of Shares that may be issued pursuant to awards granted under the 2005 Stock Incentive Plan, other than pursuant to stock option and stock appreciation right grants, is 2,612,500 Shares (pre-Capitalization Issue) instead of 2,750,000 Shares (pre-Capitalization Issue) under the 2003 Stock Incentive Plan;
- (vi) the maximum number of Shares which may be issued pursuant to performance-based awards (other than options and stock appreciation rights granted with an exercise or base price not less than the fair market value of a Share at the date of grant) that are granted to any participant in any one calendar year shall not exceed 200,000 Shares (pre-Capitalization Issue) (either individually or in the aggregate) under the 2005 Stock Incentive Plan versus 700,000 Shares (PreCapitalization Issue) under the 2003 Stock Incentive Plan; and
- (vii) the aggregate amount of compensation to be paid to any participant in respect of all performance-based awards payable only in cash and not related to Shares in any calendar year shall not exceed US\$300,000 under the 2005 Stock Incentive Plan as opposed to US\$800,000 under the 2003 Stock Incentive Plan.

The principal terms of the Pre-IPO Stock Incentive Plans on the Pre-IPO Options are as follows:

#### (a) Purpose

The purpose of the Pre-IPO Stock Incentive Plans is to promote the success of our Company and to increase shareholder value by providing additional means through the grant of awards to attract, motivate, retain and reward selected employees and other eligible persons of our Group.

#### (b) Who may join

Eligible Persons may participate in the Pre-IPO Stock Incentive Plans. Eligible Persons may be any of the following:

- (i) an officer (whether or not a director) or employee of our Group;
- (ii) a director of any member of our Group; or

- (iii) an individual consultant or advisor who renders or has rendered bona fide services to our Company (other than services in connection with the offering or sale of securities of our Company in a capital-raising transaction or as a market maker or promoter of our Company's securities).

(c) Types of awards

The administrator of the Pre-IPO Stock Incentive Plans (the "Administrator") shall have the discretion to determine the type of award(s) to be made to each selected Eligible Person.

The types of awards that may be granted under the Pre-IPO Stock Incentive Plans include stock options (whether as an incentive stock option (an "ISO") within the meaning of Section 422 of the United States Internal Revenue Code of 1986, as amended (the "Code") or a non-qualified stock option (an option not intended to be an ISO), stock appreciation rights and other awards).

The above awards may be granted singly, in combination or in tandem. The grant of awards such as ISOs and stock appreciation rights are subject to such additional provisions under the Pre-IPO Stock Incentive Plans, which have not been summarised in this prospectus.

(d) Subscription price

The per share exercise price for each option shall not be less than 100% of the fair market value of a Share on the date of grant of such option, except:

- (i) a stock option that is granted retroactively in tandem with or as a substitution for another award may have a per share exercise price no lower than the fair market value of a Share on the date such other award was granted; and
- (ii) a non-qualified stock option may be granted with a per share exercise price that is less than the fair market value of a Share on the date of grant, provided that such exercise price shall not be less than the per share purchase price of the Preferred Shares.

"Fair market value" of the Shares shall mean the value as established by the Administrator until such time that the Shares are listed or admitted to trade on a U.S. national securities exchange, reported on the National Market Reporting System of the U.S., or that bid and asked prices for the Shares are furnished by the NASD or a similar organization. The purchase price for any award granted under the Pre-IPO Stock Incentive Plans or any Shares to be delivered pursuant to an award under the Pre-IPO Stock Incentive Plans may be paid by means of any lawful consideration as determined by the Administrator, including services rendered by the participant.

(e) Acceptance of offer

No amount is payable by a participant on acceptance of an offer of option. Each award shall be evidenced by a written award agreement in the form approved by the Administrator and executed on behalf of our Company and if required by the Administrator, executed by the participant.

(f) Maximum number of Shares in respect of which options may be granted

The maximum number of Shares that may be issued pursuant to options granted as incentive stock options is 2,750,000 Shares (pre-Capitalization Issue) under the 2003 Stock Incentive Plan and 2,612,500 Shares (pre-Capitalization Issue) under the 2005 Stock Incentive Plan.

The maximum number of Shares that may be issued pursuant to awards, other than pursuant to stock option and stock appreciation right grants, is 2,750,000 Shares (pre-Capitalization Issue) under the 2003 Stock Incentive Plan and 2,612,500 Shares (pre-Capitalization Issue) under the 2005 Stock Incentive Plan. This limit does not apply to shares delivered in respect of compensation earned but deferred.

(g) Maximum entitlement of each participant

The maximum number of Shares subject to those options and stock appreciation rights that are granted during any calendar year to any individual is 700,000 Shares (pre-Capitalization Issue) under the 2003 Stock Incentive Plan and 200,000 Shares (pre-Capitalization Issue) under the 2005 Stock Incentive Plan.

The maximum number of Shares subject to all awards that are granted during any calendar year to any individual is 700,000 Shares (pre-Capitalization Issue) under the 2003 Stock Incentive Plan and 200,000 Shares (pre-Capitalization Issue) under the 2005 Stock Incentive Plan. This limit does not apply to shares delivered in respect of compensation earned but deferred.

(h) Rights are personal to participant

All awards are personal to the participant. They are non-transferable and shall not be subject to any sale, transfer, anticipation, alienation, assignment, pledge, encumbrance or charge. All awards shall be exercised by the participant only. All amounts payable or shares issuable pursuant to any award under the Pre-IPO Stock Incentive Plans shall be delivered only to the participant.

Notwithstanding the foregoing, the Administrator may permit awards to be exercised by and paid to certain persons related to the participant, including members of the participant's immediate family, trusts or other entities controlled by or whose beneficiaries or beneficial owners are the participant or members of the participant's immediate family pursuant to such conditions and procedures as established by the Administrator.

Furthermore, the foregoing exercise and transfer restrictions shall not apply to:

- (i) transfers to our Company;
- (ii) the designation of a beneficiary to receive benefits on the death of the participant, transfers to or exercise by the beneficiary of the participant on his/her death, transfers by will or the laws of descent and distribution;
- (iii) subject to any applicable limitations on ISOs, transfers to a family member or former family member pursuant to a domestic relations order if approved or ratified by the Administrator;
- (iv) if the participant has suffered a disability, permitted transfers or exercises on behalf of the participant by his or her legal representative; or
- (v) "cashless exercise" procedures with third parties who provide financing for, or who otherwise facilitate, the exercise of awards in accordance with applicable laws and the express authorization of the Administrator.

(i) Exercise period and duration of the Pre-IPO Stock Incentive Plans

The exercise period of each option (ISO or non-qualified stock options) granted under the Pre-IPO Stock Incentive Plans shall be ten years. The Pre-IPO Stock Incentive Plans shall have a duration of ten years.

(j) Performance goals

Awards may be granted in the sole discretion of the Administrator to officers and employees of any Group member subject to achievement of certain performance goals or business criteria and for the purpose of satisfying the requirements for "performance-based compensation" within the meaning of Section 162(m) of the Code. To qualify awards as performance-based under Section 162(m) of the Code, the applicable performance goals or business criteria must be established and approved by the Administrator during the first 90 days of the performance period (and in the case of performance

periods of less than one year, before 25% of the performance period has elapsed) and while performance relating to such performance goals or business criteria remains substantially uncertain within the meaning of Section 162(m) of the Code. The applicable performance measurement period may not be less than three months nor more than 10 years.

The maximum number of Shares which may be issued pursuant to performance-based awards (other than options and stock appreciation rights granted with an exercise or base price not less than the fair market value of a Share at the date of grant) granted to any participant in any one calendar year shall not exceed 700,000 Shares (pre-Capitalization Issue) (either individually or in the aggregate) under the 2003 Stock Incentive Plan versus 200,000 Shares (pre-Capitalization Issue) under the 2005 Stock Incentive Plan. The aggregate amount of compensation payable to any participant in respect of all performance-based awards in cash and not related to Shares in any calendar year shall not exceed US\$800,000 under the 2003 Stock Incentive Plan as opposed to US\$300,000 under the 2005 Stock Incentive Plan.

The authority of the Administrator to grant new awards that are intended to qualify as performance based compensation within Section 162(m) of the Code (other than options and stock appreciation rights granted with an exercise or base price not less than the fair market value of a Share at the date of grant) shall terminate upon the first shareholders' meeting of our Company occurring in the fifth year after the adoption of the Pre-IPO Stock Incentive Plans by the shareholders of our Company.

(k) Effect of alterations to capital, reorganization etc.

Upon or in contemplation of any reclassification, recapitalization, stock split or reverse stock split; any merger, combination, consolidation or other reorganization; any spin-off, split-up or similar extraordinary dividend distribution in respect of the Shares; any exchange of Shares or any similar, unusual or extraordinary corporate transaction in respect of the Shares; or a sale of all or substantially all the business or assets of our Company, the Administrator shall in its sole discretion as it deems appropriate and equitable make such adjustment to the terms of the awards or make provision for the occurrence of the foregoing events.

The Administrator may adopt such valuation methodologies for outstanding awards as it deems reasonable for a cash or property settlement. In the case of options, stock appreciation rights or similar rights, the Administrator may base settlement solely on any excess of the per share amount payable upon such event over the exercise or base price of the award. The Administrator may take such necessary action to permit the participant to realize the benefits intended to be conveyed with respect to the Shares in the same manner as generally available to shareholders of our Company prior to such event.

(l) Rights on winding-up

Upon a dissolution of our Company or other event described under paragraph (k) above that our Company does not survive, whether as a private company or a public company in respect of the Shares, all the outstanding options and stock appreciation rights shall become fully vested, all shares of restricted stock then outstanding shall fully vest free of restrictions and all other outstanding awards under the Pre-IPO Stock Incentive Plans shall become payable to the participant unless the Administrator shall have otherwise made provision for.

(m) Change of Control

In the event of a change of control event as defined in the Pre-IPO Stock Incentive Plans, the Administrator may in its discretion provide that any outstanding option or stock appreciation right shall become fully vested, that any share of restricted stock then outstanding shall fully vest free of restrictions and that any other outstanding award under the Pre-IPO Stock Incentive Plans shall be payable to the participant.

(n) Lapse of awards

Unless the Board otherwise expressly provides, (i) to the extent an outstanding option granted under the Pre-IPO Stock Incentive Plans has not become vested and exercisable on the date the participant's employment by or service to our Group terminates, the option to the extent unvested and unexercisable shall terminate; and (ii) any shares underlying a restricted stock award that remain subject to restrictions at the time of termination of the participant's employment by or service to our Group shall not vest and our Company may reacquire any unvested shares subject to such award in such manner and on such terms as provided by the Administrator.

Unless our Group policy or the Administrator otherwise provides, the employment relationship shall not be considered terminated in the case of (i) sick leave, (ii) military leave, or (iii) any other leave of absence authorized by our Group or the Administrator, provided that such leave shall not be for a period of more than 90 days unless reemployment on expiry of such leave is guaranteed by contract or law.

(o) Alteration of the Pre-IPO Stock Incentive Plans

The Board may from time to time amend, modify or suspend the Pre-IPO Stock Incentive Plans (in whole or in part). To the extent required by applicable law or any applicable listing agency or under the Code to preserve the intended tax consequences of the Pre-IPO Stock Incentive Plans, or otherwise deemed necessary or advisable by the Board, any amendment to the Pre-IPO Stock Incentive Plans shall be subject to shareholders' approval of our Company.

(p) Amendments to Awards

The Administrator may by agreement or resolution waive, or make changes to, the terms and conditions of awards, provided that any repricing of the per share exercise or base price of any option or stock appreciation right shall not be less than the fair market value of a Share on the date of the grant of the award. No amendment, suspension or termination of the Pre-IPO Stock Incentive Plans or change of any outstanding award granted under the Pre-IPO Stock Incentive Plans shall, without written consent of the participant, affect the rights or benefits of such participant or obligations of our Group in any materially adverse manner.

(q) Termination of the Pre-IPO Stock Incentive Plans

The Board may at any time terminate the Pre-IPO Stock Incentive Plans. Unless earlier terminated by the Board, the Pre-IPO Stock Incentive Plans shall terminate at the close of business on the day before the tenth anniversary of their effective date. The Pre-IPO Stock Incentive Plans will be terminated upon Listing.

Following termination of the Pre-IPO Stock Incentive Plans, no additional awards may be granted. Previously granted awards (and the authority of the Administrator with respect thereto, including its authority to amend such awards) shall remain outstanding in accordance with their applicable terms.

(r) Administration of the Pre-IPO Stock Incentive Plans

The Pre-IPO Stock Incentive Plans shall be administered by the Board or one or more committees appointed by the Board, which shall be comprised solely of one or more directors or such number of directors as may be required under applicable law.

With respect to awards intended to satisfy the requirements for performance-based compensation under Section 162(m) of the Code, the Pre-IPO Stock Incentive Plans shall be administered by a committee consisting solely of two or more outside directors provided that the failure to satisfy such requirement shall not affect the validity of the action of any committee otherwise duly authorized and acting in the matter.

## (s) Present status of the Pre-IPO Stock Incentive Plans

Application has been made to the Listing Committee of the Stock Exchange for the listing of and permission to deal in the Shares which fall to be issued pursuant to the exercise of any awards that have been granted under the Pre-IPO Stock Incentive Plans prior to Listing.

**B. Outstanding Pre-IPO Options**

No stock appreciation rights or performance-based awards have been granted under the Pre-IPO Stock Incentive Plans nor will such rights or awards be granted before or after Listing. Only non-qualified stock options have been granted under the Pre-IPO Stock Incentive Plans. The Pre-IPO Stock Incentive Plans will be terminated upon Listing.

## (a) 2003 Stock Incentive Plan

As of the Latest Practicable Date, only non-qualified stock options to subscribe for an aggregate of 2,750,000 Shares (pre-Capitalization Issue) or 13,750,000 (post-Capitalization Issue) (representing approximately 1.96% of the enlarged issued share capital of our Company immediately after completion of the Global Offering, assuming that the Over-allotment Option is not exercised) at an exercise price of RMB1.7647 have been granted to 11 participants by our Company and remain outstanding under the 2003 Stock Incentive Plan. All the options under the 2003 Stock Incentive Plan were granted on January 15, 2003 and are to be vested as to 25% of the total number of Shares under the options on the first anniversary date of grant, and as to the remaining 75% in 36 substantially equal monthly installments commencing on the last day of the month following the month of the first anniversary date of grant. No further options will be granted under the 2003 Stock Incentive Plan prior to the Listing Date.

Particulars of the options granted at nil consideration on January 15, 2003 under the 2003 Stock Incentive Plan, which are exercisable upon vesting until January 15, 2013 at an exercise price of RMB1.7647 (pre-Capitalization Issue) or RMB0.3529 (post-Capitalization Issue), are as follows:

<b>Grantee and Position</b>	<b>Residential Address</b>	<b>Number of Shares to be issued upon full exercise of the Pre-IPO Options (post-Capitalization Issue)</b>	<b>Percentage of issued share capital immediately after completion of the Global Offering<sup>(1)</sup></b>
<b>Directors of our Group</b>			
Hu Xiang	20E, Block E, Yuanzhong Garden Futian District Shenzhen, Guangdong Province China	4,100,000	0.58
Wang Guoying	301, Block 11, Pengxing Garden Guowei Road, Luohu District Shenzhen, Guangdong Province China	1,750,000	0.25
Qu Deqian	22F, Block 4, Haiyinchangcheng Nanshan District Shenzhen, Guangdong Province China	600,000	0.09
Xing Qibin	306, Block 26, Haiyue Garden Shekou, Nanshan District Shenzhen, Guangdong Province China	600,000	0.09

Grantee and Position	Residential Address	Number of Shares to be issued upon full exercise of the Pre-IPO Options (post-Capitalization Issue)	Percentage of issued share capital immediately after completion of the Global Offering <sup>(1)</sup>
Yan Andrew Y.	House 9, 39 Deep Water Bay Road Hong Kong	675,000	0.10
Yang Dong	Room 301, Block E, Building 6 Lizhuhuayuan, Nanshan District Shenzhen, Guangdong Province China	675,000	0.10
<b>Sub-total</b>		<b>8,400,000</b>	<b>1.21</b>
<b>Senior Management of our Group who are not Directors</b>			
Shao Zhiguo, vice president	403, Building No. 4, Pengxing Garden, No. 192 Guowei Road Luohu District, Shenzhen Guangdong Province China	1,750,000	0.25
<b>Sub-total</b>		<b>1,750,000</b>	<b>0.25</b>
<b>Ex-director of our Company and MOBI Shenzhen</b>			
Huang Jinsheng	816 Sutter Avenue Palo Alto, CA 94303 United States	450,000	0.06
<b>Sub-total</b>		<b>450,000</b>	<b>0.06</b>
<b>Consultants of our Company</b>			
Lai Yongxiang	4A 4 Building, Baihua Boarding House, Futian District Shenzhen, Guangdong Province China	1,200,000	0.17
Tech Power Enterprises Limited	Palm Grove House P.O. Box 438, Road Town Tortola, British Virgin Islands	1,200,000	0.17
Ju Xinxia	32-2-3B Yangguangzonglv Garden, Nanshan District Shenzhen, Guangdong Province China	750,000	0.10
<b>Sub-total</b>		<b>3,150,000</b>	<b>0.44</b>
<b>Total</b>		<b>13,750,000</b>	<b>1.96</b>

*Note:*

- (1) On the assumptions that the Over-allotment Option is not exercised and that all the remaining outstanding options under the Pre-IPO Stock Incentive Plans are exercised at the same time immediately upon completion of the Global Offering.

## (b) 2005 Stock Incentive Plan

As of the Latest Practicable Date, only non-qualified stock options to subscribe for an aggregate of 2,361,500 Shares (pre-Capitalization Issue) or 11,807,500 (post-Capitalization Issue) (representing approximately 1.68% of the enlarged issued share capital of our Company immediately after completion of the Global Offering, assuming that the Over-allotment Option is not exercised) at an exercise price of RMB3.66 have been granted to 104 participants by our Company and remain outstanding under the 2005 Stock Incentive Plan. All the options under the 2005 Stock Incentive Plan were granted on August 31, 2005 and are to be vested as to 25% of the total number of Shares under the options on the first anniversary date of grant, and as to the remaining 75% in 36 substantially equal monthly installments commencing on the last day of the month following the month of the first anniversary date of grant. No further options will be granted under the 2005 Stock Incentive Plan prior to the Listing Date.

Particulars of the options granted at nil consideration on August 31, 2005 under the 2005 Stock Incentive Plan, which are exercisable upon vesting until August 31, 2015 at an exercise price of RMB3.66 (pre-Capitalization Issue) or RMB0.732 (post-Capitalization Issue), are as follows:

<b>Grantee and Position</b>	<b>Residential Address</b>	<b>Number of Shares to be issued upon full exercise of the Pre-IPO Options (post-Capitalization Issue)</b>	<b>Percentage of issued share capital immediately after completion of the Global Offering<sup>(1)</sup></b>
<b>Consultant of our Company</b>			
Ge Xiaojing	10865 Grovehampton Court Reston, VA 20194-1432 United States	900,000	0.13
Ni Shanming	19C Baoxiang Court Jiabaotian Garden Luohu District Shenzhen, Guangdong Province China	400,000	0.06
<b>Sub-total</b>		<b>1,300,000</b>	<b>0.19</b>
<b>Senior management of our Group who are not Directors</b>			
Han Jianrong	1704, Block D2 Chunshulixiaoqu Shekou, Nanshan District Shenzhen, Guangdong Province China	570,000	0.08
Kong Weitong	306, Block G, Qilin Garden Yuquan Road Nanshan District Shenzhen, Guangdong Province China	500,000	0.07

<b>Grantee and Position</b>	<b>Residential Address</b>	<b>Number of Shares to be issued upon full exercise of the Pre-IPO Options (post-Capitalization Issue)</b>	<b>Percentage of issued share capital immediately after completion of the Global Offering<sup>(1)</sup></b>
Huang Jianjun	East, 3rd Floor, Block 705 No. 2 Pengxing Road Liantang, Luohu District Shenzhen, Guangdong Province China	500,000	0.07
Huang Youyuan	No. 2, 5th Floor, Unit 28 Building 7, No. 3 Andong Street Beilin District Xian, Shaanxi Province China	500,000	0.07
Liao Dong	2C, Block 2, Jinhaiyan Garden Shahe, Futian District Shenzhen, Guangdong Province China	400,000	0.06
Chen Zhaojun	508, Block 2, Haoyuan Qiaoxin Road Nanshan District Shenzhen, Guangdong Province China	365,000	0.05
<b>Sub-total</b>		<b>2,835,000</b>	<b>0.40</b>
<b>Other employees of the Group with options to subscribe for more than 500,000 Shares</b>			
Yin Xinshe	No. 150 Weiqu West Street Changan District Xian, Shanxi Province China	1,000,000	0.14
Zhang Hongya	102, 72 Building Yuanlinxin Cun, Futian District Shenzhen, Guangdong Province China	650,000	0.09
<b>Sub-total</b>		<b>1,650,000</b>	<b>0.23</b>
Other 94 employees (including 2 ex-employees) of our Group		6,022,500	0.86
<b>Total</b>		<b>11,807,500</b>	<b>1.68</b>

*Note:*

- (1) On the assumptions that the Over-allotment Option is not exercised and that all the remaining outstanding options under the Pre-IPO Stock Incentive Plans are exercised at the same time immediately upon completion of the Global Offering.

Out of a total of 25,557,500 Shares (post-Capitalization Issue) to be issued upon exercise of all the options granted under the Pre-IPO Stock Incentive Plans, options representing 8,400,000 Shares were granted to six Directors, options representing 4,585,000 Shares (post-Capitalization Issue) were granted to seven senior management staff of our Company, options representing 450,000 Shares (post-Capitalization Issue) were granted to an ex-director of our Group, options representing 4,450,000 Shares (post-Capitalization Issue) were granted to the five consultants of our Company and options representing 7,672,500 Shares (post-Capitalization Issue) were granted to 96 participants who are full-time employees (including 2 ex-employees) of our Group.

Assuming that all the outstanding options granted under the Pre-IPO Stock Incentive Plans were exercised in full on the Listing Date, the shareholding interest of the public would be reduced from approximately 31.6% to approximately 30.5% of the total issued share capital of our Company immediately after completion of the Global Offering, taking no account of any Shares which may be issued pursuant to the exercise of the Over-allotment Option, any Shares which may be allotted and issued pursuant to the exercise of any options granted under the Share Option Scheme or any Shares that may be issued by our Company pursuant to the general mandate as described under the paragraph headed “Extraordinary general meeting of our Company” in this Appendix. Our Directors will not exercise any Pre-IPO Options if, as a result of such exercise, our Company will not be able to comply with the public float requirements of the Listing Rules.

Our shareholding immediately following the Global Offering, assuming the Over-allotment Option is not exercised, would be diluted by approximately 3.5% upon the exercise of the Pre-IPO Options. Assuming that (i) the Global Offering had occurred on January 1, 2009; (ii) a total of 702,057,995 shares had been in issue during the year; (iii) all the Pre-IPO Options were exercised in full on January 1, 2009; and (iv) taking no account of any Shares which may be issued pursuant to the exercise of the Over-allotment Option, any Shares which may be allotted and issued pursuant to the exercise of any options granted under the Share Option Scheme or any Shares that may be issued by our Company pursuant to the general mandate as described under the paragraph headed “Extraordinary general meeting of our Company” in this Appendix, the exercise of the Pre-IPO Options will have diluted the unaudited pro forma forecast basic earnings per Share for the year ending December 31, 2009 from RMB0.1449 to RMB0.1398. Except as disclosed above, no further options will be granted under the Pre-IPO Stock Incentive Plans after the date of this prospectus. Our Company engaged an international valuation consultancy to make an appraisal of the fair market value of the Pre-IPO Options granted on January 15, 2003 and August 31, 2005 of RMB0.95 and RMB1.36 respectively, which represent a discount of approximately 60.2% and 43.0% respectively to the minimum Offer Price of HK\$2.72 and a discount of approximately 69.1% and 55.7% respectively to the maximum Offer Price of HK\$3.50, based on an exchange rate of RMB1.00 converted to HK\$1.14 and without taking into account of the Capitalization Issue. The exercise price of the Pre-IPO Options granted on January 15, 2003 and August 31, 2005 will be adjusted by the Capitalization Issue to RMB0.3529 and RMB0.732 respectively per Share, which represents a discount of approximately 85.2% and 69.3% respectively to the minimum Offer Price of HK\$2.72 and a discount of approximately 88.5% and 76.2% respectively to the maximum Offer Price of HK\$3.50.

An application has been made to the Listing Committee of the Stock Exchange for the listing of and permission to deal in the 25,557,500 Shares (post-Capitalization Issue) to be issued pursuant to the exercise of the Pre-IPO Options.

Except as disclosed above, other than the Share Warrant and the Series A Preferred Share Warrant (both of which had been fully exercised as of the Latest Practicable Date), no other warrants or options have been granted or will be granted by our Company prior to the Listing Date.

## 6. SHARE OPTION SCHEME

### Summary of terms

The following is a summary of the principal terms of the Share Option Scheme adopted pursuant to the written resolutions of the shareholders of our Company passed on November 25, 2009:

(a) *Purpose*

The purpose of the Share Option Scheme is to recognize and acknowledge the contributions of the Eligible Participants (as defined in paragraph (b) below) to our Group by granting options to them as incentives or rewards.

(b) *Who may join*

The Board may, in its discretion, offer to grant options to subscribe for such number of Shares as the Board may determine at an exercise price determined in accordance with paragraph (c) below to the following Eligible Participants (“Offer”):

- (i) any executive and employee of our Group; or
- (ii) any director (including non-executive directors and independent non-executive directors) of our Group; or
- (iii) any consultant, adviser and/ or agent of our Group.

(c) *Subscription price*

The subscription price of a Share in respect of any particular option granted under the Share Option Scheme shall be such price as the Board in its absolute discretion shall determine, save that such price shall at least be the higher of:

- (i) the closing price of the Shares as stated in the Stock Exchange’s daily quotations sheet on the date of Offer, which must be a day on which the Stock Exchange is open for the business of dealing in securities (“Business Day”); and
- (ii) the average of the closing prices of the Shares as stated in the Stock Exchange’s daily quotations sheet for the five Business Days immediately preceding the date of Offer.

(d) *Acceptance of Offer*

No amount is payable by an Eligible Participant on acceptance of an Offer of option. Any Offer of option may be accepted, in whole or in part, in a board lot of dealing in Shares on the Stock Exchange or an integral multiple thereof and in writing received by any Director or the secretary of our Company until 5:00 p.m. on the date specified in the Offer provided that no such Offer shall be open for acceptance after the expiry of the Scheme Period (as defined in paragraph (j) below) or after the Share Option Scheme has been terminated in accordance with the rules thereof.

(e) *Maximum number of Shares in respect of which options may be granted*

The maximum number of Shares in respect of which options may be granted under the Share Option Scheme and under any other share option schemes of our Group must not in aggregate exceed 5% of the total number of Shares in issue at the Listing Date (“Limit”). Options which have lapsed

in accordance with the terms of the Share Option Scheme (or any other share option schemes of our Company) will not be counted for the purpose of calculating the Limit. Subject to the approval of the shareholders of our Company in general meeting and/or such other requirements prescribed under the Listing Rules from time to time, our Company may refresh the Limit at any time provided that:

- (i) the Limit as refreshed does not exceed 5% of the Shares in issue as of the date of the approval by the shareholders of our Company in general meeting;
- (ii) the options previously granted (including those outstanding, cancelled, lapsed in accordance with the provisions of the Share Option Scheme or exercised Options) will not be counted for the purpose of calculating the Limit as refreshed; and
- (iii) a circular containing the information and the disclaimer, respectively required under Rule 17.02(2)(d) and Rule 17.02(4) of the Listing Rules shall be despatched to the shareholders of our Company together with the notice of the relevant general meeting.

Our Company may also with the approval of shareholders of our Company in general meeting grant options in respect of Shares in excess of the Limit (as refreshed from time to time) to Eligible Participants specifically identified by our Company. The circular issued by our Company to its shareholders shall contain a generic description of the specified Eligible Participants who may be granted such options, the number and terms of the options to be granted, the purpose of granting options to the specified Eligible Participants with an explanation as to how the options serve such purpose, the information required under Rule 17.02(2)(d) and the disclaimer required under Rule 17.02(4) of the Listing Rules.

Notwithstanding the foregoing, the Shares which may be issued upon exercise of all outstanding options granted and yet to be exercised under the Share Option Scheme and any other share option schemes of our Group at any time shall not exceed 30% of the Shares in issue from time to time. No options shall be granted under any schemes of our Company (including the Share Option Scheme) if this will result in the 30% limit being exceeded.

The maximum number of Shares in respect of which options may be granted shall be adjusted, in such manner as the auditors of our Company or an approved independent financial adviser shall certify to be appropriate, fair and reasonable in the event of any alteration in the capital structure of our Company in accordance with paragraph (r) below whether by way of consolidation, subdivision or reduction of the share capital of our Company but shall in no event exceed the 30% limit.

(f) *Maximum entitlement of each Eligible Participant*

The total number of Shares issued and which fall to be issued upon exercise of the options granted under the Share Option Scheme and any other share option schemes of our Group (including both exercised and outstanding options) to each Eligible Participant in any 12-month period up to the date of offer to grant shall not exceed 1% of the Shares in issue as of the date of offer to grant.

Any further grant of options in excess of this 1% limit shall be subject to:

- (i) the issue of a circular by our Company disclosing the identity of the Eligible Participant, the number of and terms of the options to be granted (and options previously granted to such participant) and the information as required under Rule 17.02(2)(d) and the disclaimer required under Rule 17.02(4) of the Listing Rules; and
- (ii) the approval of the shareholders of our Company in general meeting and/or other requirements prescribed under the Listing Rules from time to time with such Eligible Participant and his associates (as defined in the Listing Rules) abstaining from voting.

The number and terms (including the exercise price) of options to be granted to such participant must be fixed before the approval by the shareholders of our Company and the date of the Board meeting at which the Board proposes to grant the options to such Eligible Participant shall be taken as the date of offer of grant for the purpose of calculating the subscription price of the Shares.

(g) *Granting options to connected persons*

Any grant of options to a director, chief executive or substantial shareholder (as defined in the Listing Rules) of our Company or any of their respective associates (as defined in the Listing Rules) is required to be approved by the independent non-executive Directors (excluding any independent non-executive Director who is proposed to be an option holder).

If our Company proposes to grant options to a substantial shareholder or any independent non-executive director of our Company or their respective associates (as defined in the Listing Rules) which will result in the number of Shares issued and to be issued upon exercise of options granted and to be granted (including options exercised, cancelled and outstanding) to such person in the 12-month period up to and including the date of offer of such grant:

- (i) representing in aggregate over 0.1% of the Shares in issue; and
- (ii) having an aggregate value in excess of HK\$5 million, based on the closing price of the Shares at the date of offer of each grant, such further grant of options will be subject to the issue of a circular by our Company and the approval of the shareholders of our Company in general meeting on a poll at which all connected persons (as defined in the Listing Rules) of our Company shall abstain from voting in favour at such general meeting, and/or such other requirements prescribed under the Listing Rules from time to time.

(h) *Restrictions on the times of grant of options*

An offer to grant options may not be made after a price sensitive event has occurred or a price sensitive matter has been the subject of a decision until such price sensitive information has been published in the newspaper. In particular, no options may be offered to be granted during the period commencing one month immediately preceding the earlier of:

- (i) the date of the Board meeting for the approval of our Company's results for any year, half-year, quarterly or any other interim period (whether or not required under the Listing Rules); and
- (ii) the deadline for our Company to publish an announcement of its results for any year or half-year under the Listing Rules, or quarterly or any other interim period (whether or not required under the Listing Rules),

and ending on the date of actual publication of the results announcement.

(i) *Rights are personal to option holder*

An option is personal to the option holder and is not transferable or assignable.

(j) *Exercise period and duration of the Share Option Scheme*

Subject to the rules of the Share Option Scheme, options may be exercised by an Eligible Participant, in whole or in part, at any time during the period commencing from the date of grant and expiring at 5:00 p.m. on the business day (i) preceding the fifth anniversary of November 25, 2009 (being the date of adoption of the Share Option Scheme or (ii) preceding the expiry of the Scheme Period (as defined below), whichever is the earlier, save that no option may be exercised until the

expiry of 12 months after the date of grant. Subject to earlier termination by our Company in general meeting or by the Board, the Share Option Scheme shall be valid and effective for a period commencing from November 25, 2009 and expiring at 5:00 p.m. on the business day preceding the tenth anniversary thereof (“Scheme Period”).

(k) *Performance target*

An Eligible Participant to whom any option is granted is required to complete half year’s full time services with the Company or the Group and to achieve such performance target as determined by the Board before any exercise of his/her option.

(l) *Rights of exercise for option holders*

In the event that the grantee ceases to be an Eligible Participant under the Share Option Scheme by reason of ill-health, injury, disability or death or because his employing company ceases to be member of our Group before exercising his or her options in full, the grantee may exercise the options (to the extent not already exercised) within a period of six months of such ill health, injury, disability or death or cessation, failing which such options will lapse at the end of the relevant period.

In the event that a grantee ceases to be an Eligible Participant under the Share Option Scheme by reason of retirement in accordance with his or her contract of employment or upon expiration of his or her term of directorship before exercising his or her options in full, the grantee may exercise the options (to the extent not already exercised) within a period of six months after he or she so retires or expiration of his or her term of directorship, failing which such options will lapse at the end of the relevant period.

In the event that a grantee ceases to be an Eligible Participant under the Share Option Scheme by reason of voluntary resignation other than by reason of the circumstances set out above or by termination of his or her employment for serious misconduct or in accordance with the termination provisions of his or her contract of employment by his or her employing company before exercising his or her options in full, such options will lapse on the date he or she so ceases to be an Eligible Participant.

(m) *Discretion of the Board*

Notwithstanding the aforesaid in paragraph (l) above, in each case, the Board may in its absolute discretion decide that any option shall not so lapse or determine subject to such conditions or limitations as the Board may decide.

(n) *Rights on general offers*

If a general offer by way of takeover is made to all the shareholders of our Company and the offeror shall have obtained control of our Company as a consequence, option holders shall, subject to paragraph (k) above, be entitled at any time within the period of one month after control has been obtained to exercise the option in whole or in part (to the extent not already exercised), notwithstanding any restrictions in the terms of grant of the option which would otherwise have prevented the option from being exercised during such period. Any option that has not been so exercised within the one-month period shall cease and determine.

(o) *Rights on winding-up*

In the event a notice is given by our Company to its members to convene a general meeting for the purposes of considering, and if thought fit, approving a resolution to voluntarily wind-up our Company, our Company shall forthwith give notice thereof to all option holders and thereupon, each option holder shall be entitled to exercise all or any of his or her options (to the extent not already exercised) at any time thereafter until such resolution is duly passed or defeated or the general meeting concluded or adjourned sine die, whichever shall first occur. If such resolution is duly passed, all options shall, to the extent that they have not been exercised, lapse and determine.

(p) *Rights on compromise or arrangement between our Company and its members or creditors*

If a compromise or arrangement between our Company and its members or creditors is proposed for the purposes of a scheme for the reconstruction of our Company or its amalgamation with any other companies pursuant to the laws of the jurisdiction in which our Company was incorporated, our Company shall give notice to all the option holders on the same day as it gives notice of the meeting to its members or creditors summoning the meeting to consider such a scheme or arrangement and each option holder shall forthwith be entitled to exercise his or her option until the earlier of the date two months thereafter or the date on which the compromise or arrangement is sanctioned by the court. But the exercise of the option as aforesaid shall be conditional upon the compromise or arrangement being sanctioned by the court.

Upon such compromise or arrangement becoming effective, all options shall, to the extent that they have not been exercised, lapse and determine.

(q) *Ranking of Shares issued upon exercise of options*

The Shares to be allotted and issued upon the exercise of an option will not carry voting rights until completion of the registration of the option holder (or any other person) as the Shareholder thereof. Subject to the aforesaid, Shares allotted and issued on the exercise of options will rank *pari passu* and shall have the same voting, dividend, transfer and other rights, including those arising on liquidation, as attached to the other fully-paid Shares in issue on the date of exercise, save that they will not rank for any dividend or other distribution declared or recommended or resolved to be paid or made by reference to a record date falling on or before the date of exercise.

(r) *Effect of alterations to capital*

Upon any variation in the share capital of our Company arising from any reduction, sub-division or consolidation of share capital, any rights issue or the issue of any share capital by way of capitalization of profits or reserves or in connection with an open offer to the shareholders of our Company (each a “Relevant Event”), the number or nominal amount of Shares comprised in each option and/or the subscription price thereunder may be adjusted in any manner as the Board (having received a confirmation in writing from the auditors of our Group that in their/its opinion the adjustments proposed satisfy the requirements of the note to Rule 17.03(13) of the Listing Rules and the note thereto) may deem appropriate provided always that:

- (i) no increase shall be made in the aggregate subscription price relating to any option;
- (ii) any adjustments should give each option holder the same proportion of the share capital of our Company as that to which he or she was previously entitled prior to such adjustments;
- (iii) no adjustments shall be made which will enable a Share to be issued at less than its nominal value; and
- (iv) where the Relevant Event arises from an issue of Shares, references to options shall include references to options that have been exercised prior to the date of the adjustment in respect of Shares which otherwise do not rank and are not entitled to participate in the issue by reason of the option holder not having been then registered as the holder of the relevant Shares.

(s) *Lapse of options*

An option shall lapse automatically (to the extent not already exercised) on the earliest of:

- (i) the date of expiry of the option as may be determined by the Board;
- (ii) An option shall lapse automatically (to the extent not already exercised) on the earliest of: the date of lapse as provided in paragraphs (l), (n), (o) or (p) above; and

(iii) the date on which the options are cancelled in accordance with paragraph (u) below.

(t) *Alteration of the Share Option Scheme*

The Share Option Scheme may be altered in any respect by resolution of the Board except that:

- (i) any alteration to the advantage of the option holders or the Eligible Participants (as the case may be) in respect of the matters contained in Rule 17.03 of the Listing Rules; and
- (ii) any material alteration to the terms and conditions of the Share Option Scheme or any change to the terms of options grand,

shall first be approved by the shareholders of our Company in general meeting except where the proposed alteration takes effect automatically under the existing terms of the Share Option Scheme. Any change to the authority of the Board in relation to any alteration to the terms of the Share Option Scheme must be approved by shareholders of our Company in general meeting.

(u) *Cancellation of options*

Any unexercised option may be cancelled subject to approval by the option holder. Issuance of new options to the same option holder may only be made if there are unissued options available under the Share Option Scheme (excluding the cancelled options) within the 5% limit or the limit as refreshed pursuant to rule 4.1(b) of the Share Option Scheme and in compliance with the terms of the Share Option Scheme in force from time to time.

(v) *Termination of the Share Option Scheme*

Our Company may by resolution in general meeting or the Board may at any time terminate the Share Option Scheme and in such event no further options shall be granted but the provisions of the Share Option Scheme shall remain in force to the extent necessary to give effect to the exercise of any options granted prior thereto or otherwise as may be required in accordance with the provisions of the Share Option Scheme. Options granted prior to such termination but not yet exercised at the time of termination shall continue to be valid and exercisable in accordance with the Share Option Scheme.

(w) *Administration of the Share Option Scheme*

The Share Option Scheme shall be administered by the Board whose decision as to all matters arising in relation to the Share Option Scheme or its interpretation or effect (save as otherwise provided herein) shall be final and binding on all parties.

(x) *Condition of the Share Option Scheme*

The Share Option Scheme is conditional on the Listing Committee of the Stock Exchange granting listing of and permission to deal in the Shares which fall to be issued pursuant to the exercise of any options which may be granted under the Share Option Scheme.

(y) *Present status of the Share Option Scheme*

As of the Latest Practicable Date, no option has been granted or agreed to be granted under the Share Option Scheme.

Application has been made to the Listing Committee of the Stock Exchange for listing of and permission to deal in the Shares which fall to be issued pursuant to the exercise of any options which may be granted under the Share Option Scheme.

## 7. WAIVERS FROM COMPLIANCE WITH THE COMPANIES ORDINANCE AND THE LISTING RULES

### Pre-IPO Options

Under Rule 17.02(1)(b) of the Listing Rules, paragraph 27 of Appendix 1A and paragraph 10 of Part I of the Third Schedule to the Companies Ordinance, this prospectus is required to include details of the number, description and amount of any of our Shares which a person has, or is entitled to be given, an option to subscribe for, together with certain particulars of each option, namely the period during which it is exercisable, the price to be paid for Shares subscribed for under it, the consideration (if any) given or to be given for it or for the right to it and the names and addresses of the persons to whom it was given. We have granted options to 115 persons to subscribe for 25,557,500 Shares (post-Capitalization Issue) on the terms set out in the section entitled “5. Pre-IPO Options” in Appendix VI to this prospectus. Except for those grantees who are Directors, ex-director and senior management of the Group as disclosed in the section headed “5. Pre IPO Options” in Appendix VI to this prospectus, no grantees under the Pre-IPO Stock Incentive Plans are connected persons (as defined under the Listing Rules) or senior management of the Group.

Under the Pre-IPO Stock Incentive Plans, eligible persons include consultants or advisors who render or have rendered bona fide services to the Company (other than services in connection with the offering or sale of securities of the Company in a capital raising transaction or as a market maker or promoter of the Company’s securities). Three consultants were eligible persons under the 2003 Stock Incentive Plan, namely Mr. Lai Yongxiang, Tech Power Enterprises Limited and Ms. Ju Xinxia. Mr. Lai Yongxiang provided advisory services to the Group with respect to the direction of development in the PRC telecommunication industry and the use of applicable technology. Mr. Lai is one of the Beneficial Owners and he held 41,720,000 Shares in trust for the benefit of the Beneficial Owners from September 29, 2006 to May 30, 2007. Tech Power Enterprises Limited provided advisory services on corporate management to the Group and it is independent from the Company. Ms. Ju Xinxia provided advisory services as a company secretary to the Group. She is a member of the 39 Employee Shareholders and the company secretary of MOBI Shenzhen.

We have applied for (i) a waiver from the Stock Exchange from strict compliance with the disclosure requirements under Rule 17.02(1)(b) and paragraph 27 of Appendix 1A to the Listing Rules; and (ii) an exemption from the SFC from strict compliance with the disclosure requirements of paragraph 10 of Part I of the Third Schedule to the Companies Ordinance on the ground that full compliance with these requirements in respect of those participants of the Pre-IPO Stock Incentive Plans who are full-time or former employees of our Group and who are neither Directors, ex-director, senior management of our Group, consultants of our Company nor employees of our Group with a right to subscribe for more than 500,000 Shares (post-Capitalization Issue) (such participants to be collectively referred to as the “Grantees”) would be unduly burdensome for us due to the following reasons:

- (a) as the options granted under the Pre-IPO Stock Incentive Plans are considered as part of each Grantee’s remuneration package, individual information on such options is highly sensitive and confidential among the Grantees;
- (b) given the 94 Grantees involved, strict compliance with the applicable disclosure requirements under the Companies Ordinance on an individual basis in the prospectus will be costly and unduly burdensome on our Company in light of a significant increase in cost and timing for information compilation, prospectus preparation and printing;
- (c) the grant and exercise in full of the options granted under the Pre-IPO Stock Incentive Plans will not cause any material adverse change in the financial position of our Company;
- (d) the lack of full compliance of the applicable disclosure requirements under the Listing Rules and the Companies Ordinance will not hinder our Company in providing an informed assessment of our Company’s activities, assets and liabilities, financial position, management and prospects to its potential investors; and

- (e) the disclosure of a summary of information relating to the options granted under the Pre-IPO Stock Incentive Plans, as described in the section headed “5. Pre-IPO Options” in Appendix VI to this prospectus should provide potential investors with sufficient information to make a relevant assessment of our Company in their investment decision-making process.

The Stock Exchange has granted the waiver to us on the following conditions:

- (a) on individual basis, full details of all the options granted by our Company under the Pre-IPO Stock Incentive Plans to the Directors, the ex-director and the five consultants of our Company, the senior management and any other employees of our Group with a right to subscribe for more than 500,000 Shares (post-Capitalization Issue), including all the particulars required under Rule 17.02(1)(b) of the Listing Rules, paragraph 27 of Appendix 1A to the Listing Rules and paragraph 10 of Part I of the Third Schedule to the Companies Ordinance, are disclosed in this prospectus;
- (b) in respect of the options granted by our Company to the grantees other than those referred to in sub-paragraph (a), the following details are fully disclosed in this prospectus:
  - (i) the aggregate number of grantees;
  - (ii) the aggregate number of Shares subject to such options;
  - (iii) the consideration paid for the grant of such options; and
  - (iv) the exercise period and the exercise price for such options;
- (c) the dilution effect and impact on earnings per Share upon full exercise of the options granted under the Pre-IPO Stock Incentive Plans are disclosed in this prospectus;
- (d) the aggregate number of Shares subject to the outstanding options granted by our Company under the Pre-IPO Stock Incentive Plans and the percentage of our Company’s issued share capital of which such number represents are disclosed in this prospectus;
- (e) a summary of the Pre-IPO Stock Incentive Plans is disclosed in this prospectus; and
- (f) the list of all the grantees who have been conditionally granted options to subscribe for Shares under the Pre-IPO Stock Incentive Plans, containing all details as required under Rule 17.02(1)(b), paragraph 27 of Appendix 1A to the Listing Rules and paragraph 10 of Part I of the Third Schedule to the Companies Ordinance, will be made available for public inspection.

The SFC has granted the exemption on the following conditions:

- (a) on individual basis, full details of all the options granted by our Company under the Pre-IPO Stock Incentive Plans to the Directors, the ex-director and the five consultants of our Company, the senior management and any other employees of our Group with a right to subscribe for more than 500,000 Shares (post-Capitalization Issue), including all the particulars required under paragraph 10 of Part I of the Third Schedule to the Companies Ordinance, are disclosed in this prospectus;
- (b) in respect of the options granted by our Company to the grantees other than those referred to in sub-paragraph (a), the following details are fully disclosed in this prospectus:
  - (i) the aggregate number of grantees;
  - (ii) the aggregate number of Shares subject to such options;
  - (iii) the consideration paid for the grant of such options;

- (iv) the exercise period and the exercise price for such options; and
- (c) the list of all the grantees who have been conditionally granted options to subscribe for Shares under the Pre-IPO Stock Incentive Plans, containing all details as required under paragraph 10 of Part I of the Third Schedule to the Companies Ordinance, will be made available for public inspection.

## **8. OTHER INFORMATION**

### **A. Estate duty**

We have been advised that no material liability for estate duty is likely to fall on us or any of our subsidiaries in the PRC and that the Cayman Islands currently have no estate duty, inheritance tax or gift tax.

### **B. Indemnities given by the Beneficial Owners and Fangyi Holdings**

The Beneficial Owners and Fangyi Holdings have, pursuant to a deed of indemnity referred to in the sub-section headed “Summary of material contracts” under the section headed “Further information about the business of our Group” in this appendix, jointly and severally given indemnities in favour of our Company (for ourselves and as trustee for our subsidiaries) in connection with, among other things, (i) Hong Kong estate duty which might be payable by any member of our Group by virtue of section 35 of the Estate Duty Ordinance, Chapter 111 of the Laws of Hong Kong (or the equivalent thereof under the laws of any jurisdiction outside Hong Kong) or under the provisions of section 43 of the Estate Duty Ordinance, Chapter 111 of the laws of Hong Kong (or the equivalent thereof under the laws of any jurisdiction outside Hong Kong) on or before the date on which the Global Offering becomes unconditional (the “Effective Date”); (ii) taxation resulting from or relating to or in consequence of or by reference to any income, profits or gains earned, accrued or received (or deemed to be so earned, accrued or received) on or before the Effective Date or any event, occurring or deemed to occur on or before the Effective Date; (iii) any breach or alleged breach or non-compliance or alleged non-compliance by any member of our Group on or before the Effective Date under or with any law or regulation in or of any relevant jurisdiction; (iv) any claims, damages, losses, liabilities, expenses and proceedings incurred or suffered, or which may be incurred or suffered, by our Group in an aggregate amount exceeding RMB500,000 in respect of any pending or potential litigations; and (v) any claims, damages, losses, liabilities, costs (including cost of relocation), expenses, actions and proceedings incurred or suffered, or which may be incurred or suffered, by our Group in respect of the use of certain leased properties in the PRC.

The aforesaid deed of indemnity is conditional on the conditions set out in the paragraph headed “Conditions of the Global Offering” in the section headed “Structure of the Global Offering” being fulfilled.

### **C. Litigation**

Save as disclosed in this prospectus, neither our Company nor any of its subsidiaries is engaged in any litigation or arbitration of material importance and no litigation, arbitration or claim of material importance is known by the Directors to be pending or threatened by or against any member of our Group.

### **D. Promoters**

Our Company has no promoter as the term is defined under the Listing Rules.

### **E. Application for listing**

Piper Jaffray Asia and First Shanghai Capital have made an application on behalf of our Company to the Listing Committee of the Stock Exchange for the listing of, and permission to deal in, the Shares in issue and to be issued as mentioned in this prospectus, and any Shares which may fall to be issued pursuant to the exercise of any options granted under the Pre-IPO Stock Incentive Plans and may be granted under the Share Option Scheme.

**F. Preliminary expenses**

The preliminary expenses of our Company are estimated to be approximately HK\$13,830, and are payable by our Company.

**G. Qualifications of experts**

The following are the qualifications of the experts which have given their opinions or advice which are contained, or referred to, in this prospectus:

<b>Expert</b>	<b>Qualification</b>
Piper Jaffray Asia Limited	Licensed under the SFO for type 1 (dealing in securities) and type 6 (advising on corporate finance) regulated activities as defined under the SFO
First Shanghai Capital Limited	Licensed under the SFO for type 6 (advising on corporate finance) regulated activity as defined under the SFO
Deloitte Touche Tohmatsu	Certified Public Accountants
CCID Consulting Company Limited	Independent professional market research firm
Savills Valuation and Professional Services Limited	Chartered professional surveyors and valuers
Maples and Calder	Cayman Islands legal advisers
Zhong Lun Law Firm	PRC legal advisers

**H. Consents of experts**

Each of the experts referred to above has given and has not withdrawn its written consent to the issue of this prospectus with inclusion of its report and/or letter and/or valuation certificate(s) and/or the references to its name in the form and context in which they are respectively included.

As of the Latest Practicable Date, none of the experts referred to above have any shareholding in any member of our Group or the right (whether legally enforceable or not) to subscribe for or to nominate persons to subscribe for securities in any member of our Group.

**I. Binding effect**

This prospectus shall have the effect, if an application is made in pursuance hereof, of rendering all persons concerned bound by all the provisions (other than the penal provisions) of sections 44A and 44B of the Companies Ordinance so far as applicable.

**J. Miscellaneous**

Except as disclosed in this prospectus:

- (a) within the two years immediately preceding the date of this prospectus, no share or loan capital of our Company or any of our subsidiaries has been issued or agreed to be issued fully or partly paid for either cash or a consideration other than cash;
- (b) within the two years immediately preceding the date of this prospectus, no share or loan capital of our Company or any of our subsidiaries is under option or is agreed conditionally or unconditionally to be put under option;
- (c) within the two years immediately preceding the date of this prospectus, no commissions, discounts, brokerages or other special terms have been granted in connection with the issue or sale of any share or loan capital of our Company or any of our subsidiaries;

- (d) since August 31, 2009 (being the date to which the latest audited consolidated financial statements of our Group were made up) there has not been any material adverse effect in the financial or trading position of our Group;
- (e) no founder, management or deferred shares or debentures of our Company or any of our subsidiaries have been issued or agreed to be issued;
- (f) all necessary arrangements have been made to enable the Shares to be admitted into CCASS for clearing and settlement;
- (g) no company within our Group is presently listed on any stock exchange or traded on any trading system; and
- (h) subject to the provisions of the Companies Law, the register of members of our Company will be maintained in Hong Kong by Computershare Hong Kong Investor Services Limited.

**K. Bilingual Prospectus**

The English language and Chinese language versions of this prospectus are being published separately, in reliance upon the exemption provided in section 4 of the Companies Ordinance (Exemption of Companies and Prospectuses from Compliance with Provisions) Notice (Chapter 32L of the Laws of Hong Kong).

**DOCUMENTS DELIVERED TO THE REGISTRAR OF COMPANIES**

The documents attached to the copy to this prospectus delivered to the Registrar of Companies in Hong Kong for registration were copies of the **WHITE**, **YELLOW** and **GREEN** application forms, the written consents referred to in the paragraph headed “Consents of experts” in Appendix VI and copies of the material contracts referred to in the paragraph headed “Summary of material contracts” in Appendix VI.

**DOCUMENTS AVAILABLE FOR INSPECTION**

Copies of the following documents will be available for inspection at the offices of Jones Day at 29th Floor, Edinburgh Tower, The Landmark, 15 Queen’s Road Central, Hong Kong during normal business hours up to and including the date which is 14 days from the date of this prospectus:

- (1) the Memorandum and Articles;
- (2) the accountants’ report prepared by Deloitte Touche Tohmatsu, the text of which is set out in Appendix I;
- (3) the report on our unaudited pro forma financial information, the text of which is set out in Appendix II;
- (4) the letters relating to our profit forecast, the texts of which are set out in Appendix III;
- (5) such audited consolidated financial statements of our Group as have been prepared for each of the companies comprising our Group for each of the three years ended December 31, 2008 and the eight months ended August 31, 2009 or from their respective dates of incorporation where this is a shorter period;
- (6) the letter, summary of valuations and valuation certificate relating to the property interests of our Group prepared by Savills Valuation and Professional Services Limited, the text of which is set out in Appendix IV;
- (7) a copy of the letter of advice prepared by Maples and Calder summarizing certain aspects of Cayman Islands company law referred to in Appendix V;
- (8) the PRC legal opinions dated December 4, 2009 prepared by Zhong Lun Law Firm;
- (9) the report dated December 4, 2009 prepared by CCID Consulting Company Limited on the communication network antenna and RF device market in China;
- (10) the rules of 2003 Stock Incentive Plan;
- (11) the rules of 2005 Stock Incentive Plan;
- (12) the rules of the Share Option Scheme;
- (13) the material contracts referred to in the paragraph headed “Summary of material contracts” in Appendix VI;
- (14) the service agreements and the letters of appointment referred to in the paragraph headed “Particulars of Directors’ service agreements” in Appendix VI;
- (15) the written consents referred to in the paragraph headed “Consents of experts” in Appendix VI;
- (16) the Companies Law; and
- (17) the list of all the grantees who have been conditionally granted options to subscribe for Shares under the Pre-IPO Stock Incentive Plans, containing all details as required under the Listing Rules and Companies Ordinance.

**MOBI 摩比**

**MOBI Development Co., Ltd.**

**摩比發展有限公司**