



**NEXTEER AUTOMOTIVE GROUP LIMITED**  
**耐世特汽車系統集團有限公司**

*(Incorporated under the laws of the Cayman Islands with limited liability)*

(Stock Code : 01316)

---

**ANNUAL  
REPORT  
2015**

---

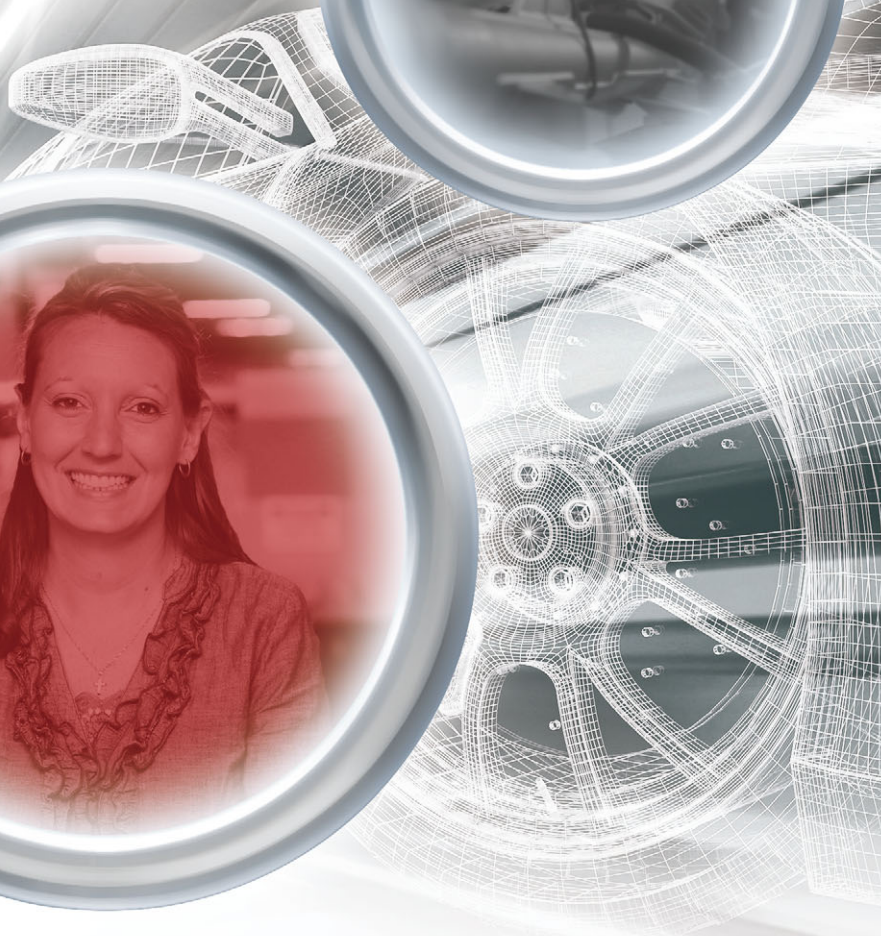



## CONTENTS

Corporate Profile	2
Corporate Information	4
Our Products	6
Business Overview	10
Financial Highlights	18
Chairman's Statement	20
Management Discussion and Analysis	22
Directors and Senior Management	30
Directors' Report	38
Corporate Governance Report	54
Independent Auditor's Report	64
Consolidated Balance Sheet	66
Consolidated Income Statement	68
Consolidated Statement of Comprehensive Income	69
Consolidated Statement of Changes in Equity	70
Consolidated Statement of Cash Flows	71
Notes to the Consolidated Financial Statements	72
Five Years' Financial Summary	136



## CORPORATE PROFILE

Nexteer Automotive Group Limited (the Company) together with its subsidiaries are collectively referred to as we, us, Nexteer, Nexteer Automotive or the Group. Nexteer Automotive is a global leader in advanced steering and driveline systems, advanced driver assist systems (ADAS) and autonomous vehicle technologies. In-house development and full integration of hardware, software and electronics give Nexteer a competitive advantage as a full service supplier.

Our vision is to be a leader in intuitive motion control – leveraging strengths in advanced steering and driveline systems. We maintain product focus on electric power steering, a socially responsible technology that offers automakers increased fuel economy and reduced emissions. Nexteer Automotive has put more than 30 million EPS units on the road, since 1999, saving more than 3 billion gallons of fuel.

Our ability to integrate our systems seamlessly into OEM vehicles speaks to our 100-year heritage of vehicle integration expertise and product craftsmanship. Our corporate culture inspires employees to achieve personal and corporate growth by focusing on the Company's core values across all aspects of the enterprise: people, operational excellence and sustainable growth.

We seek to be the partner of choice for our customers and suppliers by delivering dependable safety-critical products and building enduring relationships.

Nexteer provides real-world, vehicle-level solutions:

- Customer Focused: Respected and trusted for delivering on commitments
- Proactive: We listen carefully to understand customer requirements
- Innovative: A market leader in steering and driveline innovation
- Agile: Able to respond quickly with high-quality, cost-effective solutions
- Global: Committed to exceeding customer and vehicle needs every time, everywhere

The logo for Nexteer Automotive features the word "nexteer" in a bold, italicized, lowercase sans-serif font. A white swoosh underline starts under the 'x' and extends under the 'e'. Below "nexteer", the word "AUTOMOTIVE" is written in a smaller, all-caps, spaced-out sans-serif font.

**nexteer**  
AUTOMOTIVE

WORLD HEADQUARTERS

## CORPORATE PROFILE

## GLOBAL FOOTPRINT

<b>World Headquarters:</b>	Saginaw, Michigan, United States of America
<b>Manufacturing Plants:</b>	21
<b>Application Engineering Centers:</b>	5
<b>Customer Service Centers:</b>	11
<b>Full-Time Equivalent Global Workforce:</b>	12,000+
<b>Global Customers:</b>	50+, including BMW, Fiat Chrysler, Ford, GM, Toyota, PSA Peugeot Citroën and Volkswagen as well as domestic automakers in India, China, and South America

## OUR PRODUCTS

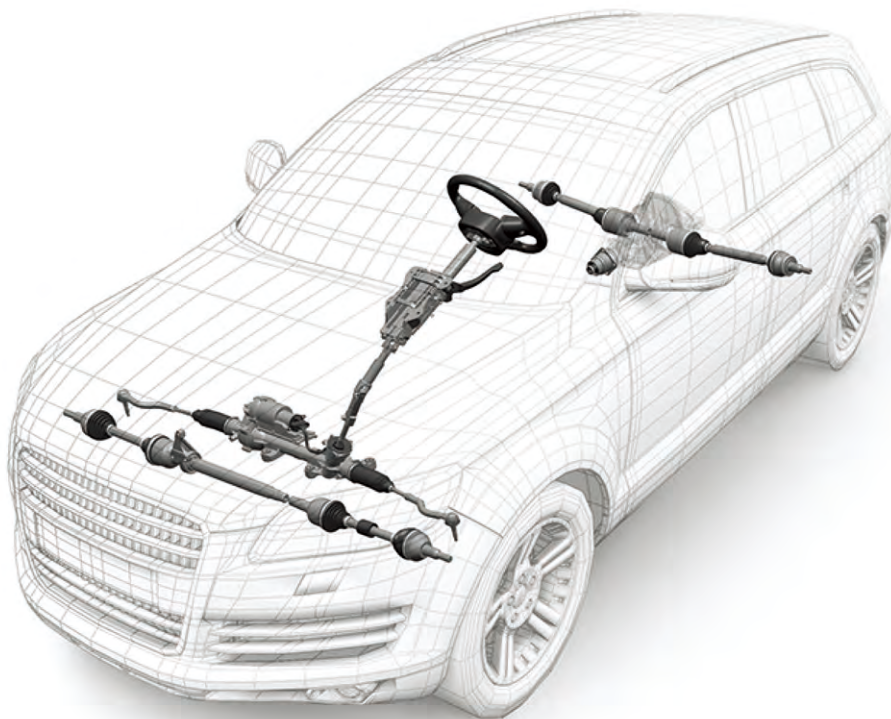

**ELECTRIC  
POWER  
STEERING**

**COLUMNS &  
INTERMEDIATE  
SHAFTS**

**DRIVELINE  
SYSTEMS**

**HYDRAULIC  
POWER  
STEERING**

# CORPORATE INFORMATION

## BOARD OF DIRECTORS

### Executive Directors

ZHAO, Guibin (趙桂斌)

*(Chairman and Chief Executive Officer)*

RICHARDSON, Michael Paul

FAN, Yi (樊毅)

### Non-Executive Directors

LU, Daen (錄大恩)

WANG, Xiaobo (王曉波)

### Independent Non-Executive Directors

TSANG, Hing Lun (曾慶麟)

LIU, Jianjun (劉健君)

WEI, Kevin Cheng (蔚成)

## JOINT COMPANY SECRETARIES

FAN, Yi (樊毅)

MOK, Ming Wai (莫明慧) (FCIS, FCS)

## AUTHORISED REPRESENTATIVES

FAN, Yi (樊毅)

MOK, Ming Wai (莫明慧) (FCIS, FCS)

## LEGAL ADVISERS

### As to Hong Kong Law

DLA Piper Hong Kong

### As to Cayman Islands Law

Maples and Calder

## AUDITOR

PricewaterhouseCoopers

## AUDIT AND COMPLIANCE COMMITTEE

WEI, Kevin Cheng *(Chairman)*

TSANG, Hing Lun

LU, Daen

## REMUNERATION AND NOMINATION COMMITTEE

TSANG, Hing Lun *(Chairman)*

LIU, Jianjun

WANG, Xiaobo

## HEADQUARTERS AND GLOBAL ENGINEERING CENTER

3900 E. Holland Road  
Saginaw, MI 48601-9494  
USA

## REGISTERED OFFICE

P.O. Box 309, Uglan House  
Grand Cayman, KY1-1104  
Cayman Islands

**CORPORATE INFORMATION****PRINCIPAL PLACE OF BUSINESS IN HONG KONG**

36/F, Tower Two  
Times Square  
1 Matheson Street  
Causeway Bay  
Hong Kong

**PRINCIPAL SHARE REGISTRAR AND TRANSFER OFFICE**

Maples Fund Services (Cayman) Limited  
P.O. Box 1093, Boundary Hall  
Cricket Square  
Grand Cayman, KY1-1102  
Cayman Islands

**HONG KONG BRANCH SHARE REGISTRAR AND TRANSFER OFFICE**

Computershare Hong Kong Investor Services Limited  
Shops 1712-1716  
17th Floor  
Hopewell Centre  
183 Queen's Road East  
Wanchai  
Hong Kong

**PRINCIPAL BANKERS**

Wells Fargo Capital Finance  
Bank of China  
Shanghai Pudong Development Bank  
CITIC  
The Export-Import Bank of China  
PKO Bank Polski  
Bank Pekao SA  
China Construction Bank

**STOCK CODES**

Share Listing  
Ordinary Shares  
The Stock Exchange of Hong Kong Limited  
(Stock code: 01316)

Senior Notes Listing  
US\$250,000,000 5.875%  
Senior Notes due 2021  
(Stock code: 05826)

**COMPANY WEBSITE**

<http://www.nexteer.com/>

## OUR PRODUCTS

**W**e design, develop, manufacture and distribute steering and driveline systems and components, primarily for original equipment manufacturers (OEMs).

A steering system consists of the components required to provide lateral directional control of the vehicle. Our steering system product lines include electric power steering, hydraulic power steering as well as steering columns and intermediate shafts.

A driveline system consists of the components required to transfer power from the transmission to the drive wheels. Our driveline system products include front wheel drive halfshafts, intermediate drive shafts and rear wheel drive halfshafts as well as propeller shaft joints.

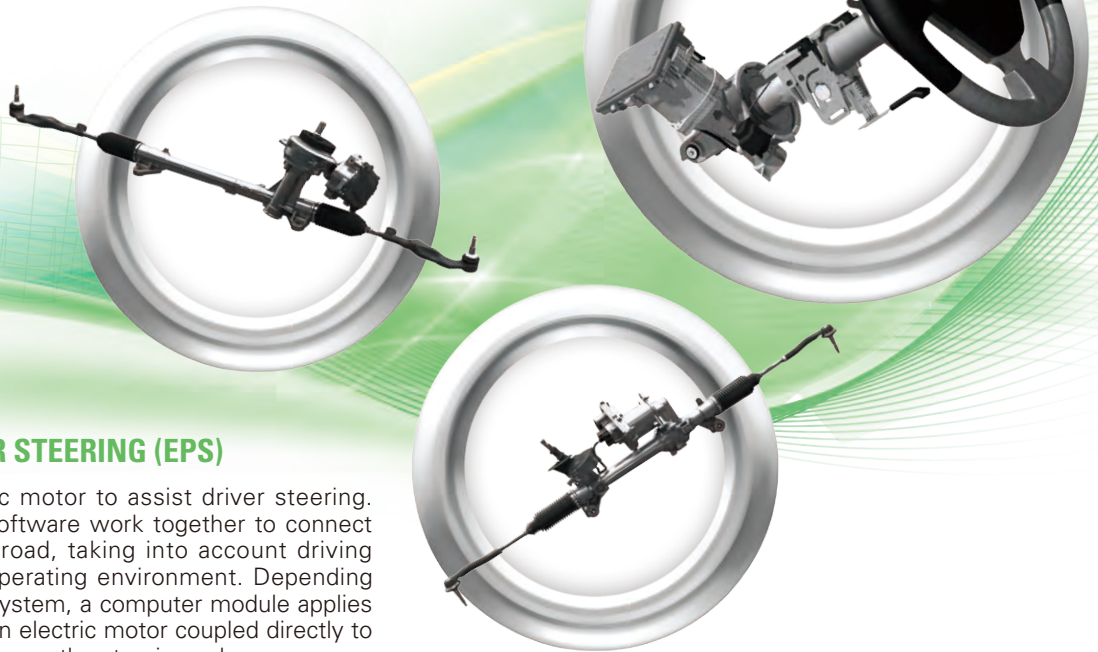

### ELECTRIC POWER STEERING (EPS)

EPS uses an electric motor to assist driver steering. Our hardware and software work together to connect the driver with the road, taking into account driving dynamics and the operating environment. Depending on the type of EPS system, a computer module applies assistive power via an electric motor coupled directly to either the steering gear or the steering column.

Column-assist EPS (CEPS) integrates system electronics (motor, controller and sensor) and the assist mechanism with the steering column. OEM customers that use our CEPS include: GM in various small cars, such as the Aveo; Shanghai GM in the Sonic and the Captiva sport utility vehicle (SUV); and Fiat Chrysler in various small cars such as the Fiat 500. In China, we also offer an entry-level brush motor column-assist EPS (BEPS) specifically tailored for developing markets. OEM customers that use our Brush CEPS include: SAIC GM Wuling Automobile for the Wuling Hongguang S minivan and Bao Jun 560 SUV.

Rack-assist EPS (REPS) integrates the required electric assist mechanism with the steering rack where they are contained under the hood in the engine compartment. OEM customers that use our REPS include: Ford in the F-150 pickup truck and the Mustang; Fiat Chrysler in the Ram pickup truck; and GM in various half-ton trucks and SUVs. We also supply our REPS in performance vehicles, including the Ford Mustang, Dodge Charger and Dodge Challenger.

Single pinion-assist EPS (SPEPS) integrates the electric assist mechanism with the steering gear pinion shaft. OEM customers that use our SPEPS include: PSA Peugeot Citroen in the Citroen C3 and DS3; Dongfeng Peugeot Citroen in the Citroen C-Elysee and the Peugeot 2008; and BMW in the 1-series, the i3 and the Mini Cooper line.



## OUR PRODUCTS

### HYDRAULIC POWER STEERING (HPS)

HPS uses high pressure fluids to assist driver steering. An engine-driven power steering pump creates system pressure. Pressurised fluid is then routed into a steering gear cylinder that turns the wheels of the vehicle. OEM customers that use our steering gears include: GM in its three-quarter ton trucks and large vans; and Fiat Chrysler in various light commercial vehicles. OEM customers that use our steering pumps include: Fiat Chrysler; GM; and PSA Peugeot Citroen.

In North America, we ramped up mass production of two new premium hydraulic based products; Magnasteer with Torque Overlay (MTO) and Smart Flow pump. These products bring advanced driver assistance functionality and reduced power consumption benefits. The MTO steering gear actuator targets  $\frac{3}{4}$  ton light truck, medium and heavy duty trucks, semis and buses. The Smart Flow pump reduces parasitic loss on the engine to improve operating efficiency. MTO and Smart Flow are currently available exclusively on GM  $\frac{3}{4}$  ton trucks, the GMC Sierra and Chevy Silverado. We also introduced an MTO cartridge valve that enables integration with OEM's current gear configurations.



### STEERING COLUMNS AND INTERMEDIATE SHAFTS (CIS)

Steering columns and intermediate shafts connect the steering wheel to the steering mechanism and control steering by transferring the driver's input torque from the steering wheel. Our advanced steering columns also provide convenience features and help protect the driver in the event of a crash. Convenience features include manual and power adjustability, theft deterrence, sensors, actuators and ergonomically designed controls. Advanced energy absorption systems help improve vehicle safety ratings and include our active systems that automatically compensate for the weight of the driver to deliver optimum protection. We design these products for small cars, SUVs and trucks. OEM customers that use our steering columns include: GM in various full-size trucks, large vans, Chevy Impala, the all new Chevrolet Camaro and Cadillac ATS; and Ford in the F-150 pickup trucks.

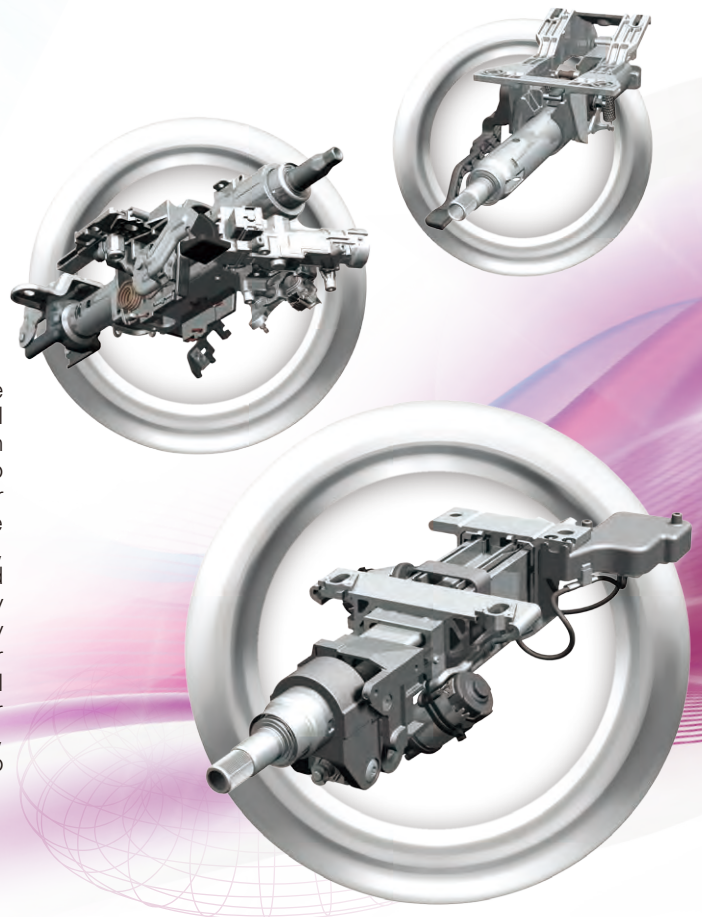



## OUR PRODUCTS

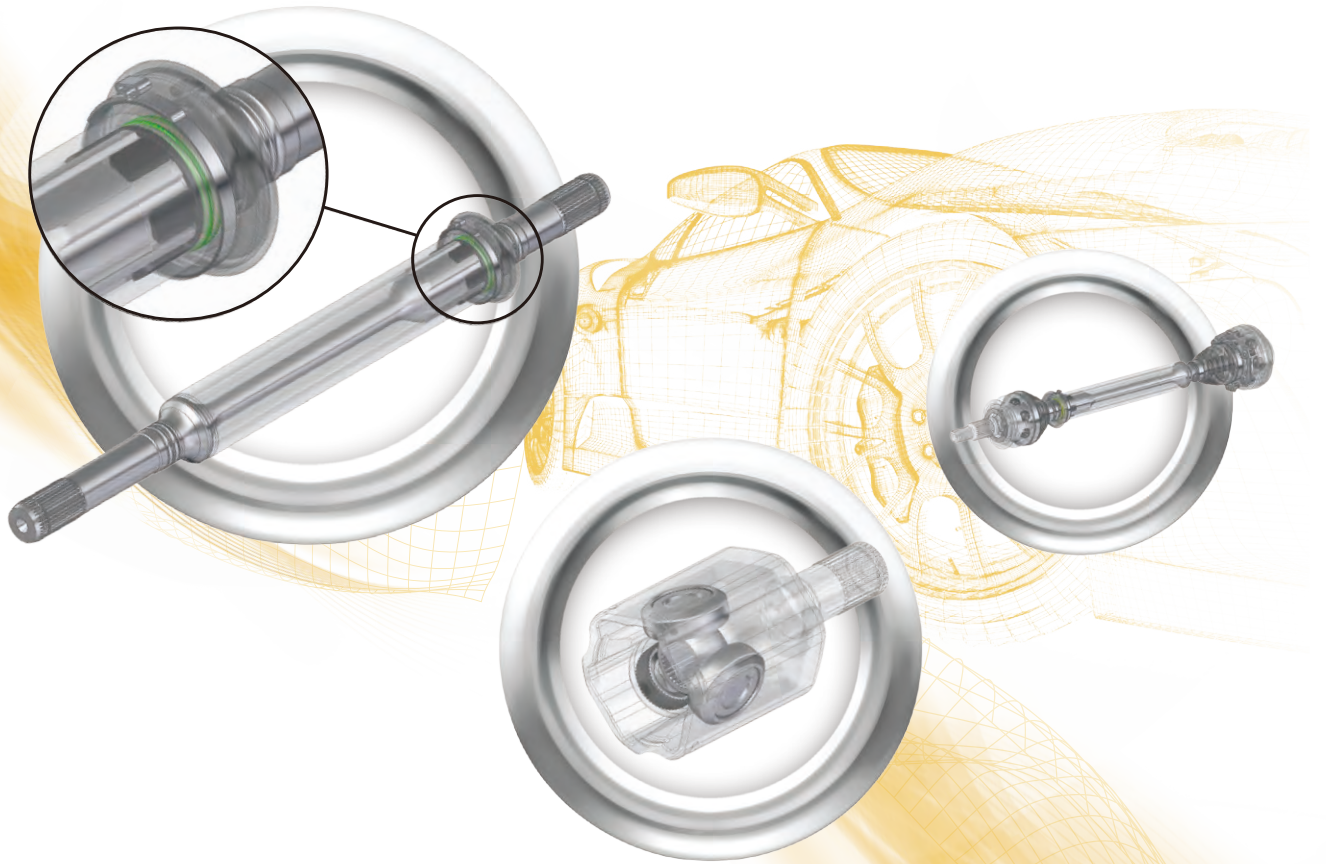

### DRIVELINE SYSTEMS

Halfshafts are designed for a variety of vehicles and are custom engineered to meet specific vehicle requirements. OEM customers that use our halfshafts include: Fiat Chrysler; GM; PSA Peugeot Citroen; Volkswagen and a number of China and India domestic OEMs.

Intermediate drive shafts work in conjunction with the halfshafts to improve vehicle handling and eliminate driveline disturbance issues on front wheel drive vehicles with unequal length axles, higher torque and running angles. OEM customers that use our intermediate drive shafts include GM in various crossover utility vehicles.

Propeller shaft joints are designed for high speed use in vehicles employing a front engine, rear drive powertrain configuration. OEM customers that use our propeller shaft joints include Ford in the Taurus, Flex and Fusion.

OUR PRODUCTS

**ADVANCED DRIVER ASSISTANCE SYSTEM (ADAS) FEATURES**

Nexteer technologies power a host of ADAS features in our advanced steering systems like EPS and MTO. In addition, a number of market trends are driving content and expansion opportunities such as increased demand for fuel efficiency, vehicle connectivity, driver assist and autonomous technologies. Even the essence of how the market defines 'mobility' is quickly evolving and fueling Nexteer's research and development activities.



# BUSINESS OVERVIEW





**BUSINESS OVERVIEW****STRATEGY FOR PROFITABLE GROWTH**

- Strengthen technology leadership
- Expand and diversify revenue base
- Capitalise on global transition to EPS
- Target China and emerging market growth
- Optimise cost structure
- Pursue select acquisitions and alliances

**2015 BUSINESS HIGHLIGHTS**

The following business highlights for 2015 demonstrate Nexteer's focus on delivering profitable growth:

- Successfully launched new production of awarded customer programs across multiple product segments, regions and customers
- Achieved new business backlog of US\$11.0 billion
- Increased exposure in China through new program launches and strength of SUV, multi-purpose vehicle (MPV) and minivan related sales
- Invested in research and development to strengthen product, technology and manufacturing leadership
- Focused on continuous improvement in operating efficiency and cost competitiveness



## BUSINESS OVERVIEW

### NEW PRODUCTION LAUNCHES

With the launch of 24 major customer programs in 2015, inclusive of 1 program from our non-consolidated joint ventures, we introduced new or improved product applications in steering columns, drivelines, HPS and EPS. These programs included incumbent and conquest business and expanded and further diversified our revenue base. Customer programs that launched or began production in 2015 included:

OEMs	Vehicle Nameplate	Our Products
<b>North America</b>		
Ford	F550, F650, F750 Mustang (RHD)	Column REPS
General Motors (GM)	Chevrolet Equinox, GMC Terrain Chevrolet Cruze Chevrolet Volt Heavy Duty Chevrolet Silverado and GMC Sierra	Driveline Driveline Driveline Column, HPS Gear, HPS Pump
Fiat Chrysler Automobiles (FCA)	Chevrolet Camaro Dodge Durango, Jeep Grand Cherokee	Column, Driveline REPS
<b>China</b>		
*Chang'An	OuShang	BEPS
GAC FCA	Jeep Cherokee	Driveline
Ford	Ranger, Everest	REPS
SAIC GM Wuling	Bao Jun 560	BEPS
SAIC GM Wuling	Hong Guang S1	BEPS
FCA	Fiorino	HPS Pump
<b>Rest of World</b>		
Renault	Logan, Sandero, Clio, Kangoo Kwid	HPS Pump Driveline
Suzuki	Every & Every Wagon	Column
Mahindra	Jeeto KUV100	Driveline Driveline
Maruti Suzuki	Alto 800, Swift	Driveline
Eicher Polaris	Multix	Driveline

\* Related to a non-consolidated joint venture

**BUSINESS OVERVIEW****BACKLOG OF BOOKED BUSINESS**

We begin to realise revenue under a new business contract at the start of production, which is generally 24 to 30 months following the date of contract award. During 2015, we secured new contracts for a number of customer programs which are expected to begin production after 2015. As at December 31, 2015, we estimate the value of all booked business under contracts that have been awarded, but which have not yet begun production, amounts to be approximately US\$11.0 billion over the production lifetime of the relevant vehicle programs (the Booked Business Amount) up from approximately US\$9.0 billion as at December 31, 2014. This robust backlog provides a strong and visible revenue stream through our projection years. The Booked Business Amount is based on estimated lifetime volume of the programs derived by the applicable OEM customers and information provided by third-party industry sources. In calculating the Booked Business Amount, we assume that the relevant contracts will be performed in accordance with their terms. Any modification or suspension of the contracts related to the booked business by the Group's customers may have a substantial and immediate effect on the value of the booked business. The value of booked business is not a measure defined by International Financial Reporting Standards (IFRS), and our methodology for determining the Booked Business Amount may not be comparable to the methodology used by other companies in determining the value of their booked business.

While we believe that our current Booked Business Amount is a relevant financial metric, we must emphasise that the information set out in this section in relation to the booked business and the Booked Business Amount shall not constitute any forecast or prediction of the profits of the Group and the actual value may differ to the estimated Booked Business Amount due to various factors beyond the Group's control.

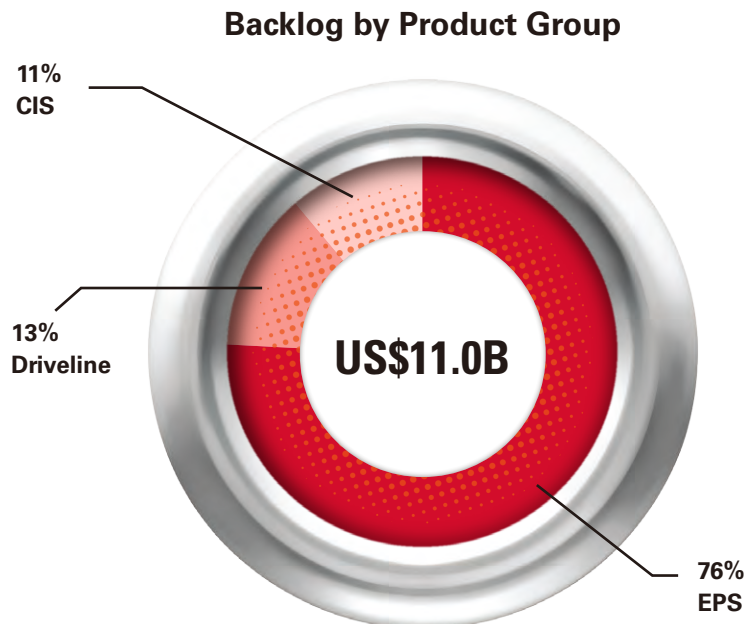
**Cumulative Booked Business:**



## BUSINESS OVERVIEW

### GROWTH IN CHINA

Nexteer achieved several significant milestones during 2015 that have expanded our customer base in the People's Republic of China (China) and position Nexteer for continued growth.

With enhanced production capabilities, the Company can take full advantage of China's ongoing conversion to Electric Power Steering (EPS) by offering a range of passenger vehicle applications, produced in the region of consumption – covering A/B segment through light commercial vehicles.

The primary driver of technical conversion from hydraulic power steering (HPS) to EPS has been regional legislation – governing automotive fuel economy & exhaust emissions. Conversion to an electric power steering system delivers one of the greatest fuel efficiency gains an OEM can make. Further, Nexteer EPS systems enable an expanding range of advanced driver assistance features such as active return to center lane keeping, haptic feedback, etc.

Nexteer is now in high volume production of an affordable brush motor-based EPS (BEPS) system in China. Market reception has been encouraging. Developed at the Company's Engineering Center in Saginaw, Michigan, USA, this high-value EPS system was optimised for local requirements at our China Application Technology Center in Suzhou to deliver advanced steering performance to China domestic and developing market customers.

Production for this product began in late 2013 and grew to an average monthly output of more than 75,000 units during 2015. We are adding new BEPS programs like SAIC GM Wuling's Bao Jun 560 and Wuling Hong Guang S1, which also began production in the first half of 2015.

In 2015, the Company registered a new indirect wholly-owned subsidiary, Nexteer Automotive Systems (Liuzhou) Co., Ltd., in China to expand manufacturing capacities for BEPS.

With the successful introduction of high-output REPS for the Ford Ranger and Everest during 2015 in the Company's Suzhou plant, China now produces the entire Nexteer EPS product portfolio. This REPS product is consumed in China, South Africa, Argentina and Australia.

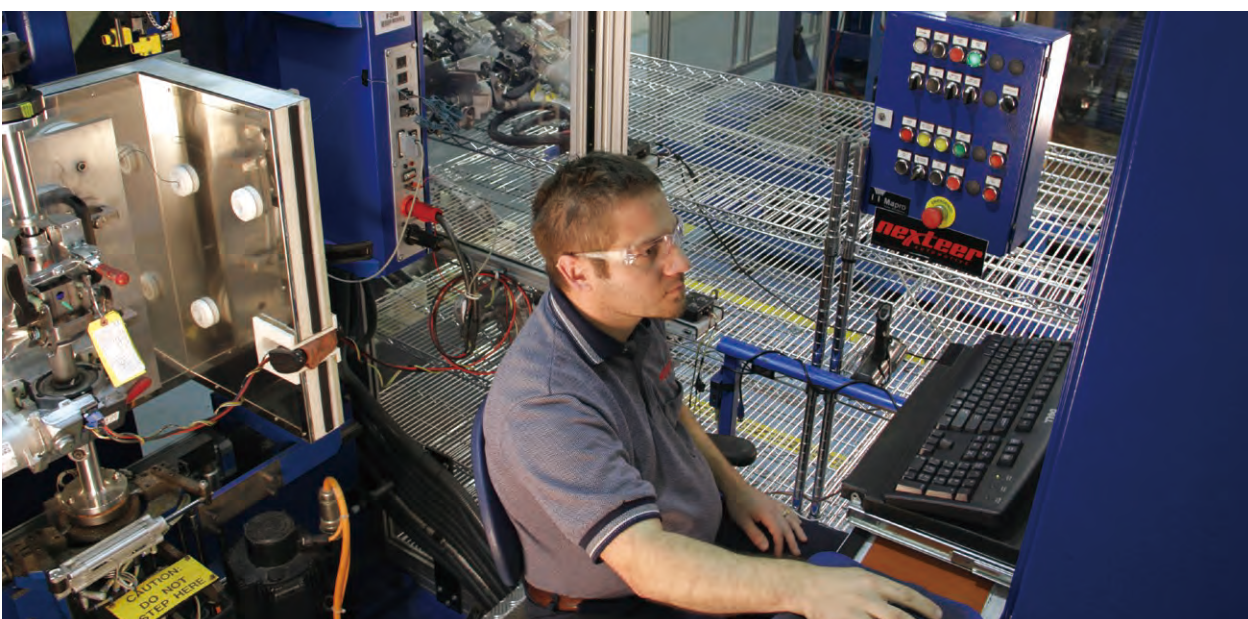

## BUSINESS OVERVIEW

The Company continues to increase market share in China through localised production.

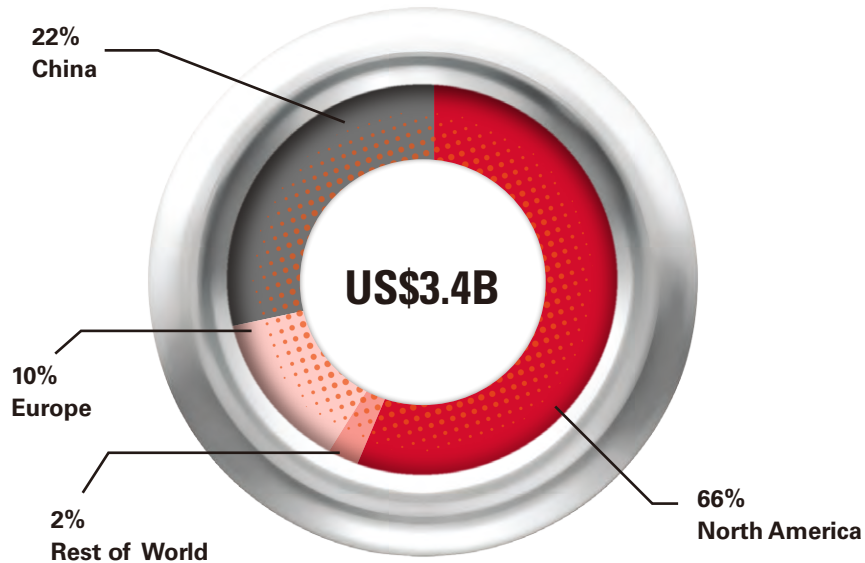

Revenue as a % of total revenue for the year ended December 31, 2015

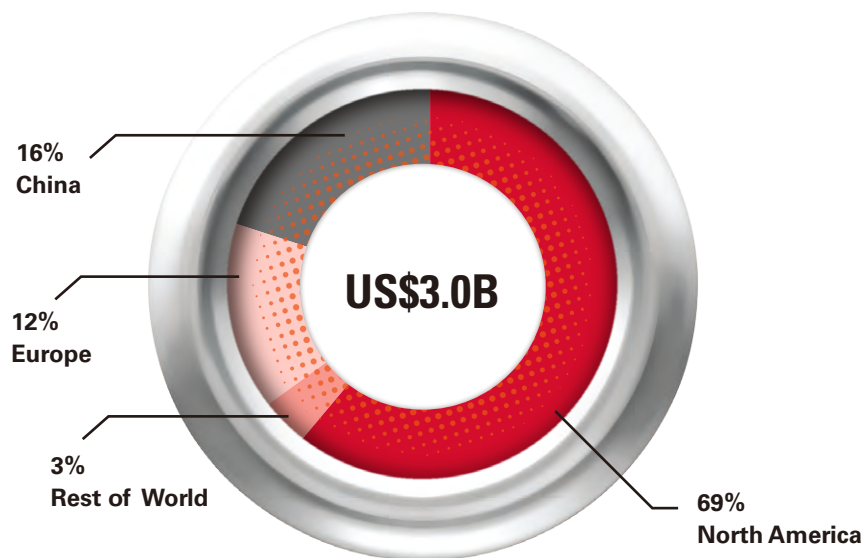

Revenue as a % of total revenue for the year ended December 31, 2014

## BUSINESS OVERVIEW



### PRODUCT RESEARCH AND DEVELOPMENT

We have accumulated extensive technical knowledge and developed a high degree of technical expertise through our approximately 100+-year history as a steering and driveline systems supplier with a consistent focus on research and development. Imperative to our continued success, we strive to maintain a competitive advantage with our current product portfolio. Concurrently, we are accelerating our focus on technology and innovation to position us to enter adjacent markets. This enhanced focus will further enable our global engineering team to drive higher levels of innovation and alignment across all our current and future product portfolios.

Our technology leadership in steering and vehicle control systems demonstrates our ability to deliver leading edge innovations to the industry. With the ongoing electrification of vehicle systems, the future of personal mobility continues to shape the automotive industry. Nexteer has been at the forefront of this emerging trend with the application of vehicle integration know-how to electric power steering systems. Our expertise and long-experience as a systems integrator positions us well as we consider avenues to grow the business.

As the automotive industry looks to define the future of mobility, the Company has identified a number of opportunities to pursue the development of ADAS, autonomous driving, and vehicle connectivity.

In the first quarter of 2015, Nexteer joined the University of Michigan Mobility Transformation Center (MTC) as an affiliate of the program. Nexteer along with 27 other companies, including OEMs and suppliers, will play a critical role in shaping a viable system of connected and automated vehicles with the MTC. We see it as our responsibility to use our advanced technology in a way that improves the safety, sustainability and accessibility of advanced mobility systems.

We are increasing our pace of innovation with transformative ways of thinking and working in research and development (R&D). From expanding and restructuring our R&D organisation all the way to re-configuring our work environments for greater collaboration across technical specialties, Nexteer is poised for fast-tracking new, profitable business growth both within and beyond the automotive industry space – as a global leader in intuitive motion control.



## BUSINESS OVERVIEW

### FOCUS ON OPERATIONAL EFFICIENCY AND COST COMPETITIVENESS

During 2015, we continued to optimise our enterprise systems technology architecture to drive operational efficiency and cost competitiveness. In January 2015, we deployed the initial phase of a new human capital management system that will enable the transformation of our human resource processes from administrative to strategic. This will result in standardised global processes and reporting that will enable improved execution of strategies, enhanced productivity and data accuracy.

Nexteer received numerous awards recognising the Company's operation excellence and leadership, including:

In June 2015, Nexteer received the Enterprise Technology Leadership Award from the Manufacturing Leadership Community. Nexteer was awarded for the implementation of its QAD cloud-based enterprise resource planning (ERP) system that improves efficiencies in all global business operations by removing legacy systems. Winners were chosen by a panel of expert judges for results that enabled the manufacturers to set themselves apart from their competitors and that have delivered clear and compelling value, return on investment, and other tangible outcomes. In Poland, the Company received the Central and Eastern Europe (CEE) Manufacturing Excellence Award for a new and innovative surface measurement system.

The Company also received customer awards for its China and Poland operations during the reporting period. SAIC GM Wuling (SGMW) recognised our Suzhou operations with the 'Best Supplier' award. This is the top award SGMW presents to its suppliers, who must demonstrate excellent performance on all aspects of manufacturing in order to qualify. Among 1,000 SGMW suppliers, only 7 suppliers received the 'Best Supplier' designation. PSA Peugeot-Citroen also recognised our Poland Tychy Plant with the 'PSA Best Plant 2015' award for its manufacturing excellence.



# FINANCIAL HIGHLIGHTS

Results (US\$'000)	2015	2014	Growth rate %
Revenue	3,360,512	2,978,068	12.8%
Gross profit	544,903	419,998	29.7%
Profit before income tax	283,364	214,596	32.0%
Income tax expense	(73,216)	(51,339)	42.6%
Net profit attributable to equity holders of the Company	205,432	161,398	27.3%
Net profit	210,148	163,257	28.7%
Adjusted EBITDA	455,410	355,717	28.0%

## REVENUE



## GROSS PROFIT



## FINANCIAL HIGHLIGHTS

## ADJUSTED EBITDA

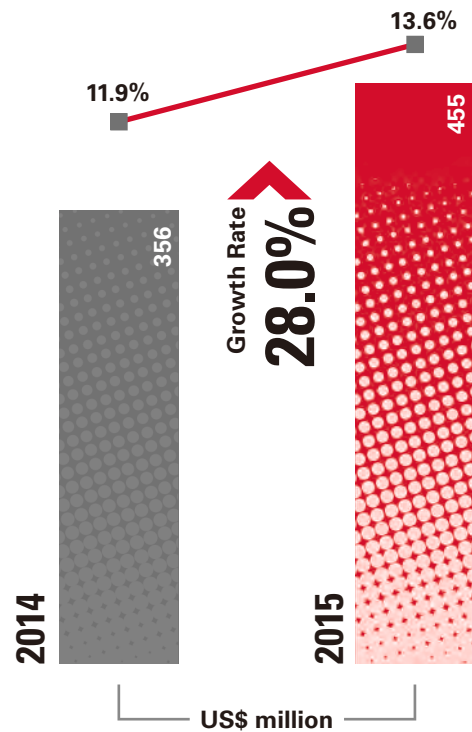

## NET PROFIT ATTRIBUTABLE TO EQUITY HOLDERS OF THE COMPANY

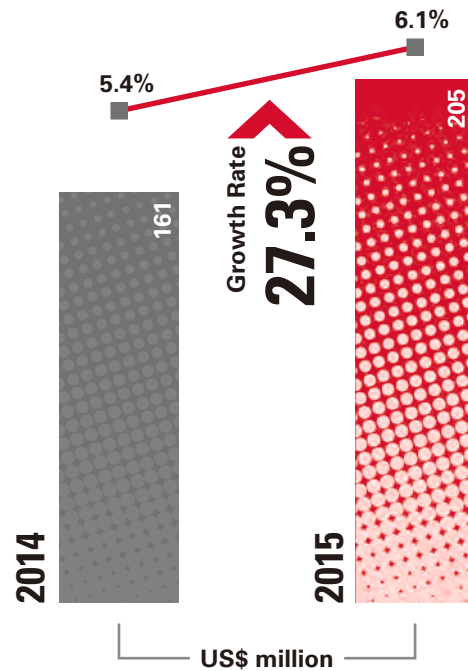

Assets and Liabilities (US\$'000)	2015	2014	Change %
Non-current assets	1,120,672	996,462	12.5%
Current assets	1,336,150	1,225,510	9.0%
Non-current liabilities	795,131	832,088	(4.4%)
Current liabilities	807,326	681,865	18.4%
Equity attributable to the Group's equity holders	827,422	683,619	21.0%

These financial highlights should be read in conjunction with the Group's audited Consolidated Financial Statements.



# CHAIRMAN'S STATEMENT



**"As a growing, balanced enterprise we are well positioned for the future, driven by entrepreneurial thinking and a focus on technology leadership."**

**ZHAO Guibin**  
Chairman

## Dear Shareholders:

On behalf of the Board of Directors (Board) of Nexteer Automotive Group Limited (Nexteer of the Company), I present to our shareholders (Shareholders) the annual report for the financial year ended December 31, 2015.

In December 2015, we celebrated our fifth anniversary as an independent company and the significant accomplishments made in this relatively brief period of time. By strengthening our technology leadership and streamlining operations, we transformed the Company into a cash flow positive and profitable enterprise with record earnings of US\$210.1 million in the current reporting period. We have also increased revenue by 63.8% from US\$2,051.9 million at the end of 2010 to US\$3,360.5 million at the end of 2015, with the past two reporting periods delivering accelerated growth.

We continue to advance a strategy of diversification with new customers, new products, and new regions of operations.

Our 2015 backlog of booked business (Booked Business) remains strong at US\$11.0 billion in lifetime revenue. The composition of Booked Business provides an indication of our decreasing dependency on General Motors of 6.2% and continued market expansion in EPS of 3.5%.

Our healthy and flexible capital structure enables us to consider targeted acquisitions and alliances appropriate for the business. This assessment is encouraging and will provide a solid foundation as we look to develop collaborative strategies to continue to grow the enterprise globally.

We are pleased that the hard work of our dedicated employees has been recognised by our Shareholders and the financial markets.

In September 2015, Nexteer was added to the Hang Seng Composite Large Cap & Mid Cap Index (HSLMI), a significant milestone for the Company. Our inclusion recognises the progress and achievements that Nexteer has delivered since our IPO in 2013. We are also pleased that our shares are now accessible to investors in mainland China through the Shanghai-Hong Kong Stock Connect program.

Nexteer strives to be a model company in the global market. In a quantitative assessment of corporate governance and earnings quality factors conducted in the second quarter of 2015, Macquarie ranked Nexteer at the top of a group of peer companies with significant securities appreciation potential.

We are committed to continuously improving our internal control systems and transparency. To meet stakeholders' expectations in environmental, social and governance (ESG) factors we will publish our first sustainability report in April 2016 – demonstrating our commitment to creating shareholder value in a socially responsible manner.

## CHAIRMAN'S STATEMENT

As a growing, balanced enterprise, we are well positioned for the future, driven by entrepreneurial thinking and a focus on technology leadership.

### REVIEW OF RESULTS

In 2015, Nexteer continued creating value for Shareholders. For the year ending December 31, 2015, the Group's revenue was US\$3,360.5 million, representing an increase of approximately 12.8% from US\$2,978.1 million in 2014. Revenue from non-U.S. markets amounted to US\$1,827.8 million, representing growth of 17.0% from US\$1,562.3 million in 2014. Profit attributable to equity holders of the Company was US\$205.4 million representing an increase of 27.3% from US\$161.4 million in 2014. The Group's gross profit was US\$544.9 million, representing an increase of 29.7% from US\$420.0 million in 2014.

Nexteer continues to make global diversification a priority. In 2015, 66.0% of revenue was delivered from North America, 10.1% from Europe, 21.8% from China and 2.1% from Rest of World.

### FUTURE PROSPECTS

Numerous market trends are presenting expansion opportunities within our core business such as increased demand for fuel efficiency, vehicle connectivity, driver assist and autonomous vehicle technologies. The very essence of how the market defines 'mobility' is evolving and shaping Nexteer's research and development activities.

The Nexteer team is leveraging our driver assistance products and technology to enhance the autonomous driving experience using both conventional product development and disruptive thinking. Our steer-by-wire production history and ongoing research and development are central building blocks to meeting this objective. This effort resulted in the booking of our first development contract on an autonomous vehicle with a North American vehicle manufacturer.

As a leader in intuitive motion control, we believe that focusing on current success is not sufficient to maximise the growth potential of the enterprise. With this in mind, we are approaching the market as an entrepreneurial and innovative organisation. We have made strategic investments adjacent to our core business to expand our diversification efforts.

Taking lessons learned from Silicon Valley, we launched a business and technology development group (SYNTecrity). This team operates independent of our traditional R&D organisation and maintains focus on the quick identification and advancement of new portfolio products and functional capabilities for next generation autonomous vehicles.

Global mega trends are also creating growth opportunities in areas outside of traditional automotive. We have established a separate business development group to explore the application of existing products and core competencies in adjacent markets.

Along with growth opportunities on the horizon for 2016 and beyond, Nexteer will continue to monitor the needs of global markets and look for favorable opportunities within the domain of intuitive motion control. Through responsible stewardship of core competencies and deliberate pursuit of commercial opportunities, we intend to ensure long-term success of the Company.

I am proud of what we have accomplished in our journey to transform Nexteer into an agile, lean and independent global company. With a robust long term strategy and a strong balance sheet, Nexteer is poised for sustainable profitable growth.

### APPRECIATION

On behalf of the Board, I would like to express my sincere appreciation to our management team and our over 12,000 employees worldwide for their unwavering dedication in making Nexteer a leader in intuitive motion control. I extend additional thanks to our Shareholders. Your belief and support afford Nexteer the ability to thrive in a dynamic global marketplace and to build a solid platform for continued growth.

I encourage you to review the material contained in this report, and sincerely value your continued support of Nexteer.

**ZHAO Guibin**  
*Chairman*

March 15, 2016

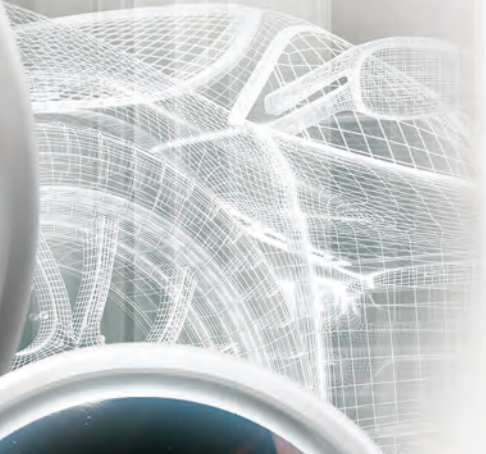

# MANAGEMENT DISCUSSION AND ANALYSIS





## MANAGEMENT DISCUSSION AND ANALYSIS

The following management discussion and analysis should be read in conjunction with the Consolidated Financial Statements, included herein, which have been prepared in accordance with IFRS as issued by the International Accounting Standards Board.

### FINANCIAL REVIEW

#### Financial Summary

The Group advanced its strong financial position in 2015. Robust industry production and improved markets in North America, China, and Europe led to increased volume. The Group also continued to successfully launch new products in China, North America and Rest of World to deliver continued top line revenue growth. The Company's strong top line growth through successful launches and focus on operational efficiency, coupled with a strong automotive market, continues to drive earnings and cash flow accretion.

#### Operating Environment

The global automotive market has a direct impact on our business and operating results. The factors affecting the industry include macro-economic factors such as consumer confidence, fluctuations in commodity, currency, fuel prices, and regulatory environments. The Company operates primarily in North America, China, Europe, India and Brazil. Automotive industry production levels increased in 2015 over 2014 despite stable, yet lackluster, growth in the global economy. Improvements were seen in North America where global light vehicle production increased 2.7% from the year ended December 31, 2014 to the year ended December 31, 2015. In China, the automotive market continues to expand and thus provide a benefit to the Group. The China global light vehicle production increased 4.3% from the year ended December 31, 2014 to the year ended December 31, 2015. Additionally, the Group has benefitted from strong mix with SUV's. The European market continued modest growth. The European global light vehicle production increased 3.8% from the year ended December 31, 2014 to the year ended December 31, 2015. The environment in India remained stable with signs of growth while the environment in Brazil deteriorated. Global light vehicle production in rest of world including India, Brazil, Korea, and Australia declined 3.6% from the year ended December 31, 2014 to the year ended December 31, 2015.

The Group's profit attributable to equity holders of the Company for the year ended December 31, 2015 was US\$205.4 million or 6.1% of total revenue, an increase of 27.3% compared to the year ended December 31, 2014 of US\$161.4 million or 5.4% of total revenue. This increase was attributable to the following:

- Successfully launched new production of awarded customer programs across multiple product segments, regions and customers
- Increased customer demand due to market strength
- Increased exposure in China through new program launches and strength of SUV, MPV and minivan related sales
- Focused on continuous improvement in operating efficiency and cost competitiveness
- Improved product line mix (continued conversion from HPS to EPS)

## MANAGEMENT DISCUSSION AND ANALYSIS

### Revenue

The Group's revenue for the year ended December 31, 2015 was US\$3,360.5 million, an increase of US\$382.4 million or a 12.8% increase from the year ended December 31, 2014 of US\$2,978.1 million. The Group's revenue was negatively impacted by US\$87.0 million of foreign exchange. The Group's revenue would have increased an additional 3.0% from the year ended December 31, 2014 excluding the foreign exchange impact.

We measure the results of our operations by geographic segment regions. The change in revenue is analysed by volume, mix and price. Volume measure changes are driven by the volume of products sold. Mix changes are driven by the type of products sold. Price measures the impact of changes within the pricing structure of each product sold.

### Revenue by Geographical Segments

For the year ended December 31, 2015, the Group experienced an increase in revenue in North America and China segments. This increase was partially offset by a decline in revenue in the Europe and Rest of World segments.

	For the year ended December 31, 2015		For the year ended December 31, 2014	
	US\$'000	%	US\$'000	%
North America	2,216,849	66.0	2,041,975	68.6
China	732,736	21.8	468,092	15.7
Europe	340,146	10.1	363,191	12.2
Rest of World <sup>1</sup>	70,781	2.1	104,810	3.5
<b>Total</b>	<b>3,360,512</b>	<b>100.0</b>	<b>2,978,068</b>	<b>100.0</b>

Note:

1 Includes Brazil, India, Korea and Australia.

The change in revenue by geographical segments is primarily due to the following:

- The North America segment experienced an 8.6% increase in revenue from the year ended December 31, 2014 to the year ended December 31, 2015 which is consistent with strong North America automotive industry production. The North America segment benefitted from increased volume as a result of increased end-user customer demand for new vehicles and new customer program launches. The North America segment launched eleven new customer programs in both 2015 and 2014. The increased volume is primarily attributed to EPS and CIS programs.
- The China segment experienced a 56.5% increase in revenue for the year ended December 31, 2015 compared to the year ended December 31, 2014. The increase is directly attributable to our increased market share in the China market. The China segment launched ten new customer programs in 2014 and six in 2015. Additionally, main model sales to key customers are strong, which is allowing for sales above the overall market.
- The Europe segment experienced a 6.3% decrease in revenue from the year ended December 31, 2014 to the year ended December 31, 2015. This decrease is attributable to unfavorable foreign exchange offset by improved customer demand. The negative foreign exchange impact on revenue for the Europe segment was US\$62.0 million with a negative EBITDA impact of US\$20.2 million. The Europe segment revenue would have increased 10.7% from the year ended December 31, 2014 to the year ended December 31, 2015 excluding the negative foreign exchange impact.
- The Rest of World segment experienced a 32.5% decrease in revenue from the year ended December 31, 2014 to the year ended December 31, 2015. This decrease is attributable to the reduction of sales in Korea, and unfavorable customer demand as a result of the less than favorable economic environment in Brazil.

## MANAGEMENT DISCUSSION AND ANALYSIS

### Revenue by Products

The following table sets forth the Group's revenue by product lines for the period indicated:

	For the year ended December 31, 2015		For the year ended December 31, 2014	
	US\$'000	%	US\$'000	%
Steering				
EPS	2,000,287	59.5	1,668,140	56.0
HPS	167,337	5.0	183,054	6.1
CIS	609,565	18.1	583,082	19.6
Driveline	583,323	17.4	543,792	18.3
	3,360,512	100.0	2,978,068	100.0

The increase in steering production revenue primarily results from the growth of the EPS products sold as the Group transitions from HPS to higher priced EPS systems. Substantial volume increases have amplified due to customer demands, as well as successful launch of conquest business from backlog of booked business.

### Cost of Sales

The Group's cost of sales for the year ended December 31, 2015 was US\$2,815.6 million, an increase of US\$257.5 million from US\$2,558.1 million for the year ended December 31, 2014. The Group's cost of sales for the year ended December 31, 2015 primarily included raw material costs of US\$1,923.0 million, manufacturing expense of US\$826.3 million, as well as other costs of sales of US\$66.3 million.

The Group's cost of sales increased as a result of increased sales volume. The increase was partially offset by cost efficiencies in raw material and improved quality resulting in a reduction in warranty expense of US\$11.6 million in the year ended December 31, 2015 from the year ended December 31, 2014. However, the Company experienced increased depreciation on property, plant, and equipment, and increased amortisation of capitalised product development costs in the year ended December 31, 2015 when compared to the year ended December 31, 2014. The increased depreciation and amortisation is consistent with an increase in programs launched. The depreciation and amortisation charged to cost of sales for the year ended December 31, 2015 was US\$133.8 million, an increase of US\$19.2 million from the year ended December 31, 2014.

### Gross Profit and Gross Margin

The Group's gross profit for the year ended December 31, 2015 was US\$544.9 million, an increase of US\$124.9 million or 29.7% from US\$420.0 million for the year ended December 31, 2014. Gross margin for the year ended December 31, 2015 was 16.2%, a 2.1% increase from 14.1% for the year ended December 31, 2014. The increase in the gross profit was attributed to increased revenue from continued rotation to EPS and cost improvement initiatives. This was partially offset by unfavorable foreign exchange, depreciation on property, plant, and equipment, and amortisation of capitalised product development costs.

### Engineering and Product Development Costs

For the year ended December 31, 2015, the Group's engineering and product development costs charged to the income statement was US\$96.9 million, representing 2.9% of revenue, an increase of US\$16.8 million from US\$80.1 million or 2.7% of revenue for the year ended December 31, 2014. The stable engineering and product development costs as a percentage of revenue is attributable to efficiency of scale with increased revenue growth. The absolute increase in engineering and product development costs includes additional global headcount as the Company continues its strong focus on engineering and product development.

Engineering development costs capitalised as intangible assets, including capitalised interest, for the year ended December 31, 2015 were US\$109.3 million (year ended December 31, 2014: US\$102.1 million).

Amortisation of capitalised product development costs recorded as cost of sales amounted to US\$50.9 million for the year ended December 31, 2015, an increase of US\$12.6 million from US\$38.3 million for the year ended December 31, 2014. We expect amortisation expense to continue to increase in future years with the launch of several programs that are currently in development.

## MANAGEMENT DISCUSSION AND ANALYSIS

### Administrative Expenses

The Group's administrative expenses for the year ended December 31, 2015 were US\$105.5 million, an increase of US\$16.3 million, or 18.3% compared to the year ended December 31, 2014. The increase was primarily due to increased support aligned to our strategy of continued growth.

### Other Losses, net

Other losses, net represents losses attributable to foreign exchange transactions, loss on disposal of property, plant, and equipment, and fair value losses on derivative financial instruments. Other losses for the year ended December 31, 2015 were US\$17.4 million, an increase of US\$11.9 million compared to the year ended December 31, 2014. The increase is driven by unfavorable foreign exchange transaction loss and loss on derivative financial instruments associated with forward exchange contracts.

### Finance Costs, net

Finance costs, net, consist of interest income and expense reduced by interest capitalised on qualifying assets and product development. The Group's net finance costs as at the year ended December 31, 2015 were US\$31.0 million which is an increase of US\$9.4 million from the year ended December 31, 2014. The increase was primarily due to increased interest expense related to the senior unsecured notes (Notes) issued in November 2014. Finance costs, net, were offset by US\$5.5 million of interest capitalised for the year ended December 31, 2015 compared to US\$4.7 million for the year ended December 31, 2014.

### Income Tax Expense

The Group's income tax expense was US\$73.2 million for the year ended December 31, 2015, representing 25.8% of the Group's profit before income tax, an increase of US\$21.9 million from US\$51.3 million, or 23.9% of profit before tax for the year ended December 31, 2014.

The US\$21.9 million increase in income tax expense is primarily the result of additional income tax expense incurred on the incremental US\$68.8 million of profit before tax for the year ended December 31, 2015. The change in the mix of income generated by US and non-US operations unfavorably impacted the effective tax rate for the year ended December 31, 2015.

### Provisions

As at December 31, 2015, the Group has provisions of US\$89.7 million for restructuring, litigation, environmental liabilities, warranties and decommissioning, an increase of US\$9.2 million from US\$80.5 million as at December 31, 2014. This increase in provisions was attributable to several individually insignificant claims.

### Liquidity and Capital Resources

#### Cash Flows

Our business requires a significant amount of working capital, which is primarily used to finance the purchase of raw materials, capital spending for customer programs, and engineering and product development costs. We have historically met our working capital and other capital requirements principally from cash generated from operations and loans from banks. In recent years, the Group has invested extensively in capital equipment and engineering and product development costs. For the year ended December 31, 2015, the Group invested US\$165.6 million and US\$111.9 million in capital equipment and engineering product development, respectively. Due to an increase in cash generated from operating activities, the Group has reduced the principal balance on some of its borrowings.

The Company was total cash flow positive for the year ended December 31, 2015. We believe that in the future our liquidity and capital expenditure requirements will be satisfied by cash generated from operating activities.



## MANAGEMENT DISCUSSION AND ANALYSIS

The following table sets forth a condensed statement of cash flows for the Group for the years indicated:

	<b>For the year ended December 31, 2015 US\$'000</b>	For the year ended December 31, 2014 US\$'000
Cash generated from/(used) in:		
Operating activities	468,266	254,066
Investing activities	(276,389)	(275,704)
Financing activities	(161,510)	90,509
Total increase in cash	30,367	68,871

#### *Cash Flows Generated from Operating Activities*

For the year ended December 31, 2015, the Group's cash generated from operating activities was US\$468.3 million, an increase of US\$214.2 million compared to the year ended December 31, 2014 of US\$254.1 million. The increase in cash flows from operating activities is primarily due to increased earnings and reduced demands for working capital.

#### *Cash Flows Used in Investing Activities*

The Group's cash flows used in investing activities primarily reflect capital spending for customer programs. Our capital expenditures include cash expenditures for the purchases of machinery, equipment and tooling and investment in product development.

In the year ended December 31, 2015, the Company invested US\$3.1 million in a 50% owned joint venture in Chongqing, China to manufacture and sell EPS products (year ended December 31, 2014: US\$6.4 million).

The following table sets forth the cash used in investing activities within the Group for the years indicated:

	<b>For the year ended December 31, 2015 US\$'000</b>	For the year ended December 31, 2014 US\$'000
Purchase of property, plant and equipment	(165,609)	(172,482)
Addition of intangible assets	(111,867)	(106,602)
Proceeds from sale of property, plant and equipment	3,536	6,759
Change in restricted bank deposits	623	2,983
Investment in a joint venture	(3,072)	(6,362)
Total cash used in investing activities	(276,389)	(275,704)

## MANAGEMENT DISCUSSION AND ANALYSIS

### *Cash Flows Used in Financing Activities*

The Group's net cash used in financing activities was US\$161.5 million for the year ended December 31, 2015, which was mainly attributable to the net repayment of borrowings of US\$91.4 million, finance costs paid of US\$37.0 million, dividends paid of US\$33.4 million, and proceeds from the exercise of options of US\$0.3 million.

### **Indebtedness**

As at December 31, 2015, the Group's total indebtedness was US\$641.7 million which was a US\$89.3 million decrease from December 31, 2014. This decrease is due to the utilisation of cash generated through operations to pay maturing debt.

The following table sets forth the balances of short and long-term borrowing obligations within the Group for the years indicated:

	<b>December 31, 2015 US\$'000</b>	December 31, 2014 US\$'000
Current borrowings	80,483	96,586
Non-current borrowings	559,349	633,700
Finance lease obligations	1,891	696
<b>Total borrowings</b>	<b>641,723</b>	730,982

The table below sets forth the maturity profile of borrowings within the Group for the years indicated:

	<b>For the year ended December 31, 2015 US\$'000</b>	For the year ended December 31, 2014 US\$'000
Within 1 year	81,184	96,970
Between 1 and 2 years	75,115	74,233
Between 2 and 5 years	236,051	252,733
Over 5 years	249,373	307,046
<b>Total borrowings</b>	<b>641,723</b>	730,982

Details of the borrowings of the Group during the period are set out in note 17 to the Annual Consolidated Financial Information.

## MANAGEMENT DISCUSSION AND ANALYSIS

### Pledge of Assets

The Group has several secured borrowings at specific subsidiaries. The assets securing the borrowings differ by site and include accounts receivable, inventory, property, plant and equipment, the equity interests of certain subsidiaries and intellectual property. For the year ended December 31, 2015, the Group had approximately US\$968.9 million total assets pledged as collateral, an increase of US\$78.0 million from the US\$890.9 million as at December 31, 2014.

### Exposure to Currency Rate Fluctuations and Related Hedges

The Group actively limits its foreign currency exposure by focusing on naturally matching its purchase of materials and sale of finished goods in the same currencies. The Group monitors its remaining foreign currency exposure regularly to reduce the risk of foreign currency fluctuations in its operations. The Group currently hedges its exposure USD risk to the Mexican Peso, Polish Zloty, and the European Euro by participating in a hedging program that includes forward exchange contracts. The total notional principal amount of the outstanding contracts at December 31, 2015 was US\$127.9 million (December 31, 2014: US\$64.8 million).

### Gearing Ratio

The Group monitors capital structure on the basis of the debt ratio. The ratio is calculated as total borrowings divided by total equity at the end of the respective year.

The gearing ratio as at December 31, 2015 was 75.1%, a decrease of 28.1% from December 31, 2014. The ratio decreased compared to 2014 due to improved profits and payment of borrowings.

## OTHER INFORMATION

### Future Prospects

The Group strives to be a leader in global advanced Steering and Driveline systems by leveraging technology leadership. Our global footprint allows us to capitalise on the transition of the market to EPS and continued growth in China and other emerging markets. In addition to strengthening and expanding our current business and customer relationships, we are positioned to pursue selected strategic acquisitions and/or alliances globally.

### Employees and Remuneration Policy

As at December 31, 2015, the Group had over 12,000 full-time equivalents of which approximately 11,600 are direct employees of the Group. The Group's remuneration policies are formulated based on the performance of individual employees and the Company's performance and are reviewed regularly. Our full time employees participate in various employee benefit plans including retirement benefits, extended disability benefits and workers' compensation. In addition, we have adopted employee incentive plans designed to attract, retain, motivate, and encourage employees to commit to enhancing value for us and our Shareholders as a whole. For example, the Group has retention programs that include individual development plans, merit wage adjustments, annual incentive plans and promotions.

In order to achieve the business target and customer requirements, such as regulatory requirements and contract commitment, a variety of skills trainings are tailor-made and provided to employees.

# DIRECTORS AND SENIOR MANAGEMENT

## DIRECTORS

The Board is responsible and has general powers for the management and conduct of our business. The following table sets out certain information concerning the Directors:

Name	Age	Position title	Date of appointment(s)	Roles and responsibilities
<b>Executive Directors</b>				
ZHAO, Guibin (趙桂斌)	52	Chairman, Executive Director and Chief Executive Officer	June 15, 2013 and June 2012, respectively	Overseeing our Group's strategic vision, direction and goals and overseeing the overall execution of our Group's strategy
RICHARDSON, Michael Paul	59	Executive Director, Senior Vice President, Business Strategy	June 15, 2013 and June 2012, respectively	Overseeing our Group's strategic planning
FAN, Yi (樊毅)	49	Executive Director, Vice President and Joint Company Secretary	August 21, 2012, November 14, 2013 and January 28, 2013, respectively	Managing our Group's operations and handling of company secretarial duties
<b>Non-Executive Directors</b>				
LU, Daen (錄大恩)	55	Non-executive Director	August 21, 2013	As a non-executive Director
WANG, Xiaobo (王曉波)	39	Non-executive Director	August 21, 2013	As a non-executive Director
<b>Independent Non-Executive Directors</b>				
TSANG, Hing Lun (曾慶麟)	66	Independent Non-executive Director	June 15, 2013	As an independent non-executive Director
LIU, Jianjun (劉健君)	47	Independent Non-executive Director	June 15, 2013	As an independent non-executive Director
WEI, Kevin Cheng (蔚成)	48	Independent Non-executive Director	June 15, 2013	As an independent non-executive Director



## DIRECTORS AND SENIOR MANAGEMENT

### Executive Directors

**ZHAO, Guibin (趙桂斌), (Chairman and Chief Executive Officer)**, aged 52, was appointed as our Executive Director and chairman of the Board on June 15, 2013. He is also our Chief Executive Officer since June 2012. Mr. ZHAO has 18 years of relevant experience in the automotive industry. He is primarily responsible for setting our strategic vision, direction and goals and overseeing the overall execution of our Group's strategy. Mr. ZHAO also is a director and the chairman of the board of directors of Nexteer Automotive Corporation, one of our indirectly wholly-owned subsidiaries. Mr. ZHAO has been a director of Pacific Century Motors, Inc. (PCM China), one of our Controlling Shareholders, since December 2010, and chairman of the board of directors and general manager of AVIC Automotive Systems Holding Co., Ltd., (AVIC Auto) a wholly-owned subsidiary of AVIC, one of our Controlling Shareholders, since 2010 and from 2009 to 2010, respectively. He is also the deputy chief economist of Aviation Industry Corporation of China (AVIC). Since September 2015, Mr. Zhao is the director of AVIC Hande (Beijing) Investment Holding Ltd. Co. and HENNIGES Automotive Holding Inc. both of which are non-wholly owned subsidiaries of AVIC Auto. From April 2010 to April 2013, Mr. ZHAO was the chairman of the board of directors of AVIC Heavy Machinery Co. Ltd., a non-wholly-owned subsidiary of AVIC, and a company listed on the Shanghai Stock Exchange (stock code: 600765). From 1997 to 2003, Mr. ZHAO was the general manager of Sichuan Lingfeng Aeronautics Hydraulic Machinery Co., a wholly-owned subsidiary of AVIC, where he was in charge of corporate governance and operational management. He was appointed as general manager, director and chairman of AVIC Chengdu Engine (Group) Co., Ltd., a wholly-owned subsidiary of AVIC, and as a director and the chairman of the board of its non-wholly-owned subsidiary, Sichuan Chengfa Aero Science and Technology Co., Ltd in August 2003. Mr. ZHAO became a first-tier senior economist in September 2004, awarded by China Aviation Industry Corporation. He was awarded an executive master's degree in business administration by the University of Electronic Science and Technology of China, China, in June 2007. Mr. ZHAO has received numerous awards in recognition of his achievements, including the Government Special Allowance awarded by the People's Republic of China State Council in 2000.

**RICHARDSON, Michael Paul**, aged 59, was appointed as our Executive Director on June 15, 2013. Mr. RICHARDSON has been senior vice president, responsible for business strategy since June 2012. Mr. RICHARDSON has over 41 years of relevant experience in the automotive industry. He is responsible for our Group's strategic planning, as well as mergers and acquisitions. Mr. RICHARDSON began his automotive career with GM in 1974, as a co-operative student at the former Saginaw Steering Gear Division. He became a staff engineer for the halfshaft product line in 1990. From 1992 to 1995, Mr. RICHARDSON was a staff engineer for steering products, and from 1995 to 1999, he was regional director of engineering, production control and logistics, based in Paris, France. In 1999, Mr. RICHARDSON returned to the United States as chief engineer of hydraulic power steering. He was promoted to director of engineering of Delphi Steering in 2001. From 2006 to 2009, Mr. RICHARDSON relocated to Shanghai, China, where he became regional director of the Asia-Pacific region. In 2009, Mr. RICHARDSON returned to the United States, and was made vice president of the steering business line. In 2011, Mr. RICHARDSON became chief operating officer (China division) of our Group while retaining his business line and global engineering responsibilities. He is currently based in our Saginaw office. Mr. RICHARDSON is a professional engineer, awarded in 1984 by the State of Michigan, U.S.A. He obtained a bachelor's degree in mechanical engineering from Kettering University (formerly known as General Motors Institute), U.S.A. in 1979 and a master's degree in business administration from Central Michigan University, U.S.A. in 1990. He is a Boss Kettering Award recipient and was inducted into the Delphi Innovation Hall of Fame for career innovation in 2004. Mr. RICHARDSON holds a Masters Professional Director Certification from the American College of Corporate Directors.

## DIRECTORS AND SENIOR MANAGEMENT

**FAN, Yi (樊毅)**, aged 49, was appointed as our Director on August 21, 2012 and was designated as our Executive Director on June 15, 2013. He was appointed as our Joint Company Secretary on January 28, 2013 and was appointed as our vice president on November 14, 2013. He is responsible for the management of our operations and handling of company secretarial duties. Mr. FAN has approximately 17 years of relevant experience in the automotive industry. Mr. FAN currently serves as a director of our three directly held subsidiaries, Nexteer UK Holding Ltd., Nexteer (China) Holding Co., Ltd., PCM (Singapore) Steering Holding Pte. Limited and as a director of several of our subsidiaries. Mr. FAN has held the following positions in our Controlling Shareholders, namely, deputy general manager of AVIC Auto since January 2012; general manager since July 2013 and director and secretary to the board of directors of PCM China since 2010; and the sole director of Nexteer Automotive (Hong Kong) Holdings Limited (Nexteer Hong Kong) since its incorporation in August 2012. From 1992 to 1999, Mr. FAN worked at the economic research center of AVIC Corporation. From 1999 to 2005, Mr. FAN served as management director of the automotive department of China Aviation Industry Corporation. Since 2005, he started working in the automotive department of AviChina Industry & Technology Company Limited, a company listed on The Stock Exchange of Hong Kong Limited (Stock Exchange) (stock code: 2357), a non-wholly-owned subsidiary of AVIC, where he was initially deputy manager, and was later appointed as manager in 2007. Mr. FAN graduated in 1987 from Beijing Aviation Institute of Aeronautics and Astronautics, the China (now known as Beijing University of Aeronautics and Astronautics, China with a bachelor's degree in engineering from the Faculty of Automatic Control, and completed a master's research course in education, economics and management from Beijing University of Aeronautics and Astronautics, China, from 1999 to 2001. Mr. FAN was certified as a researcher in natural sciences by China Aviation Industry Corporation in September 2007.

### Non-Executive Directors

**LU, Daen (錄大恩)**, aged 55, was appointed as our Non-executive Director on August 21, 2013. Mr. LU is responsible for participating in our Group's strategic and key operational decision-making processes and advising on our strategies and policies. Mr. LU has 20 years of relevant experience in the automotive industry. Mr. LU was appointed as a director and general manager of AVIC Auto, one of our Controlling Shareholders, in March 2013 and April 2013, respectively, and a director of PCM China, one of our Controlling Shareholders, in July 2013. Since September 2015, Mr. Lu is the chairman and general manager of AVIC Hande (Beijing) Investment Holding Ltd. Co. and HENNIGES Automotive Holding Inc. both of which are non-wholly owned subsidiaries of AVIC Auto. From 2004 to July 2010, Mr. LU served as director and general manager of AVIC Xinxiang Aviation Industry (Group) Co. Ltd., an indirectly wholly-owned subsidiary of AVIC, and then served as the chairman from September 2010 to May 2013. Mr. LU held various positions in AVIC Xinxiang Pingyuan Aviation Equipment Co., Ltd.), an indirect wholly-owned subsidiary of AVIC, from August 1981 to June 2004, including cost accountant of finance section, deputy section manager, head of finance department, deputy chief accountant and general manager. Mr. LU was awarded as a senior accountant by AVIC, one of our Controlling Shareholders, in 1994. He obtained his master's degree in law from Huazhong University of Science and Technology, China in 2001.

**WANG, Xiaobo (王曉波)**, aged 39, was appointed as our Non-executive Director on August 21, 2013. Mr. WANG is responsible for participating in our Group's strategic and key operational decision-making processes and advising on our strategies and policies. Mr. WANG has approximately four years of relevant experience in the automotive industry. Mr. WANG was appointed as director of PCM China, one of our Controlling Shareholders, in July 2014. He has served as general manager of Beijing E-Town International Investment & Development Co., Ltd. (Beijing E-Town) since February 2012. From August 2011 to March 2012, he served as deputy general manager of Beijing E-Town. Mr. WANG was general manager of Beijing E-Town Digital Display Industry Management Co., Ltd. since December 2009 and deputy manager of Business Development Department of Beijing Economic-Technological Investment & Development Corporation. Mr. WANG held various positions in Management Committee of Beijing Yanqing Economic Development Area from September 2005 to September 2006, including manager of development section and manager of planning section. Prior to this, Mr. WANG held various positions at the Management Committee of Beijing Yanqing Economic Technology Development Area, including manager of development section from August 2004 to September 2005, deputy manager of development section from January 2003 to August 2004 and section member of development section from August 1998 to January 2003. Mr. WANG graduated from Inner Mongolia University, China in July 1998 and obtained a bachelor's degree in English language.

## DIRECTORS AND SENIOR MANAGEMENT

### Independent Non-Executive Directors

**TSANG, Hing Lun (曾慶麟)**, aged 66, was appointed as our Independent Non-executive Director on June 15, 2013. Mr. TSANG has over 32 years of experience in the banking, finance and wealth management sectors, and has held the following independent non-executive directorships in publicly listed companies: as an independent non-executive director and chairman of the audit committee of China Huarong Energy Company Limited (formerly known as China Rongsheng Heavy Industries Group Holdings Limited), (stock code: 1101) from October 2010 to May 2014; as an independent non-executive director and chairman of the audit committee of Sinotrans Shipping Limited, (stock code: 368) since August 2007; as an independent non-executive director and chairman of the audit committee of Sino-Ocean Land Holdings Limited (stock code: 3377) since June 2007; as an independent non-executive director and chairman of the audit committee of Beijing Media Corporation Limited (stock code: 1000) from November 2004 to May 2013; as an independent non-executive director of China GrenTech Corporation Ltd. (delisted on the NASDAQ after April 30, 2012) from September 2011 to April 2012; and as an independent non-executive director and chairman of the audit committee of First China Financial Network Holdings Limited (formerly known as International Financial Network Holdings Ltd) (stock code: 8123) from June 2005 to January 2011.

Mr. TSANG has served in the senior management of several publicly listed companies operating in Hong Kong and Singapore. Mr. TSANG has been chairman of Influential Consultants Ltd. (欣斌顧問有限公司) since July 1998. Mr. TSANG was a deputy general manager of China Construction Bank, Hong Kong Branch (中國建設銀行香港分行) from 1995 to 1998. He was an executive director of the Hong Kong Stock Exchange in 1993. Mr. TSANG joined United Overseas Bank Limited in Singapore (新加坡大華銀行集團) in March 1990 as its first vice president. Prior to that, he was with Hang Seng Bank for 17 years from 1973 to 1990, where he was assistant general manager of the planning and development division in the last 5 years. In addition, Mr. TSANG became qualified as a Certified Financial Planner in March 2010, and as a financial planner in China in July 2006. Mr. TSANG became a fellow of the Hong Kong Institute of Directors in July 2001, was admitted as a fellow of the Association of Certified Accountants in November 1982, and became a fellow of the Hong Kong Institute of Certified Public Accountants (formerly known as the Hong Kong Society of Accountants) in December 1978. Mr. TSANG graduated from Chinese University of Hong Kong, Hong Kong, with a bachelor's degree in business administration (first class honors) in October 1973.

**LIU, Jianjun (劉健君)**, aged 47, was appointed as our Independent Non-executive Director on June 15, 2013. Mr. LIU was in the legal department of China Ocean Shipping (Group) Company container lines (中國遠洋運輸集團總公司 集裝箱運輸) from July 1993 to March 1999, a partner at Zhong Sheng Law Firm (北京中盛律師事務所), Beijing from April 2001 to October 2006, a senior associate in Zhong Lun Law Firm, Beijing (北京中倫律師事務所) from November 2006 to May 2007, and has been a partner at Zhonglun W&D Law Firm (北京中倫文德律師事務所), Beijing since June 2007. Mr. LIU started practicing as lawyer in China in August 2001. He obtained a master's degree in law from Peking University, China, in July 1998, and a law degree from Washington University in St. Louis, the U.S., in May 2004.

## DIRECTORS AND SENIOR MANAGEMENT

**WEI, Kevin Cheng (蔚成)**, aged 48, was appointed as our Independent Non-executive Director on June 15, 2013. Mr. WEI is currently a managing partner of a company focused on corporate finance advisory and investment banking business. Mr. WEI has held the following independent non-executive directorships in publicly listed companies: as an independent non-executive director of Tibet Water Resources Ltd (formerly known as Tibet 5100 Water Resources Holdings Ltd. (西藏5100水資源控股有限公司)) (stock code: 1115) since March 2011; and as an independent non-executive director of Wisdom Sports Group (formerly known as Wisdom Holdings Group (智美控股集團)) (stock code: 1661) since July 2013.

Mr. WEI served as a chief financial officer of IFM Investments Limited, a real estate services company headquartered in Beijing, from December 2007 to September 2013. IFM Investments Limited was delisted from NYSE in 2015. Prior to that, from 2006 to 2007, Mr. WEI served as the chief financial officer of Solarfun Power Holdings Co., Limited (stock code: SOLF), a NASDAQ listed solar company (now known as Hanwha SolarOne Co., Ltd and relisted on NASDAQ as Hanwha SolarOne (stock code: HSOL). Mr. WEI became a member of the American Institute of Certified Public Accountants in February 1999. He graduated in June 1991 from Central Washington University, the U.S., where he received his Bachelor of Science degree (cum laude) with a double major in accounting and business administration.

### SENIOR MANAGEMENT

Our senior management is responsible for the day-to-day management of our business. The table below shows certain information in respect of the senior management of our Company (collectively, the Senior Managers):

Name	Age	Position/Title
BRESSON, Laurent Robert	44	President and Global Chief Operating Officer
PERKINS, Joseph Michael <sup>(1)</sup>	47	Senior Vice President, Chief Financial Officer
LUBISCHER, Frank Peter Josef	53	Senior Vice President, Chief Technology Officer, Global Engineering
HOEG, Dennis Steven	60	Vice President, Global Operations, Manufacturing Engineering, and Capital Enterprise Systems
OWENBY, Douglas E.	55	Vice President, Chief Operating Officer – North America Division
LIU, Tao (柳濤)	51	Vice President, Chief Operating Officer – China Division
DECKER, Mark P.	48	Vice President, Chief Human Resources Officer

(1) Subsequent to December 31, 2015, Mr. PERKINS resigned.



## DIRECTORS AND SENIOR MANAGEMENT

**BRESSON, Laurent Robert**, aged 44, was appointed as our president in June 2012 and global chief operating officer in May 2012. He is responsible for reporting to the chairman of the Board and overseeing our Group's global functions including sales, engineering, operation, human resources, finance and global supply management, and is in charge of overseeing our Group's product lines. Mr. BRESSON is concurrently leading the Nexteer Strategy Counsel (NSC), the top strategy and policy making body in our Group. Mr. BRESSON has 21 years of relevant experience in the automotive industry. Mr. BRESSON has held various positions in the Company, including executive director from October 2009 to March 2011, vice president of global sales and marketing of the European region from March 2011 to March 2012, senior vice president from March 2012 to June 2012 and chief operating officer of the international division and global sales from March 2012 to May 2012. Mr. BRESSON also held a number of managerial positions at Delphi Corporation, including managing director (Europe) from December 2008 to October 2009 where he was in charge of European business growth and profitability, marketing and public affairs director (European sales) from May 2008 to December 2008, director of European sales and marketing, and public relations of the European customer service centers of the steering division from March 2007 to April 2008, chief engineer, sales manager and product line manager (Europe) in the power products and product line, electronic division, where he was in charge of the business growth and profitability of the product lines in Europe from mid-2005 to January 2007, and power product line engineering manager and product team leader (Europe) within the thermal and interior division from October 2002 to mid-2005, where he was responsible for mechanical engineering, advanced engineering and project management. Prior to that, Mr. BRESSON held various positions at Siemens-VDO from September 1995 to May 1999, including sales manager and engineer, amongst other roles. Mr. BRESSON became a qualified engineer at the Ecole Nationale Supérieure d'Ingenieurs in Caen, France (majoring in Electro-mechanics) in June 1994. He obtained a master's degree in science from the University of Manchester Institute of Science and Technology in Manchester, the United Kingdom, in December 1994. Mr. BRESSON was awarded the Certificat d'Aptitude à l'Administration des Entreprises (the certificate for assessing the ability to administer corporations) at the Instituts d'Administration des Entreprises in Basse Normandie, France, in October 1994, which was completed via part-time online course modules.

**PERKINS, Joseph Michael**, aged 47, was appointed as our senior vice president and chief financial officer on December 1, 2012. He has 25 years of relevant automotive sector experience including leadership responsibilities in multiple financial disciplines at three different automotive related companies including General Motors, Delphi Corporation and the Group. He is responsible for our Group's investor relations, treasury, capital funding and structure, M&A support, accounting and financial reporting, financial planning and analysis, program finance, risk management, financial controls and taxation. He is also a member of the NSC. Mr. PERKINS was an assistant finance director at the Company from October 2009 to March 2011, which included responsibilities for the successful transition of the Company and its finance function to new ownership. He later served as vice president, controller and chief accounting officer from March 2011 to December 2012, when he led the Group's reporting and financial performance and analysis functions. Mr. PERKINS was an assistant finance director of Delphi Corporation from January 2005 to October 2009, a manager in corporate financial performance at Delphi Corporation from September 2002 to December 2004, a manager in Delphi Corporation energy and chassis systems divisional financial performance from January 2000 to September 2002 and a plant controller in Delphi Corporation energy and chassis systems from May 1998 to January 2000. Prior to that, Mr. PERKINS worked at GM from January 1991 to May 1998 in various leadership positions. Mr. PERKINS obtained a Bachelor of Arts degree from Michigan State University, the U.S., in December 1990, and a master's degree in business administration from Wayne State University, the U.S., in December 1999. Mr. PERKINS also serves on a variety of non-profit boards in the U.S.

## DIRECTORS AND SENIOR MANAGEMENT

**LUBISCHER, Frank Peter Josef**, aged 53, was appointed as our senior vice president, chief technology officer, global engineering in November 2015. He is responsible for our Group's global engineering, technology definition, design and development of product portfolio and manufacturing engineering, and customer application. He has 21 years of relevant automotive managerial experience and is also a member of the NSC. Prior to joining our Group, Mr. LUBISCHER was with TRW Automotive Chassis System Engineering from 1988, where he served as vice president of global steering engineering from August 2007 to November 2012, technical director of brake systems (North America) from September 2001 to July 2007, and chief engineer of ABS Systems, North America from January 2000 to September 2001. He also worked for Lucas Automotive/LucasVarity in Germany as a development engineer, section leader and chief engineer for ABS systems from September 1988 to December 1999, before LucasVarity was integrated with TRW Automotive Chassis System Engineering in 1999. Mr. LUBISCHER obtained a CEO diploma (an executive business degree) from the SMP Institute of University of St. Gallen, Switzerland, in March 2005.

**HOEG, Dennis Steven**, aged 60, was appointed as our vice president of global operations, manufacturing engineering and capital enterprise systems in December 2012. He is responsible for our Group's global manufacturing engineering (focusing primarily on launch of products), capital plan, and enterprise system improvements. He has 38 years relevant automotive experience and is also a member of the NSC. Mr. HOEG served as vice president of engineering at Nexteer Automotive from June 2011 to November 2012. He was executive director of global supply management from 2007 to 2011, director of global manufacturing engineering from 2002 to 2007, and plant manager from 1999 to 2002 at Delphi Saginaw Steering Systems. Mr. HOEG began his automotive career with GM in 1978 as a manufacturing engineer at the former Saginaw Steering Gear division. In 1997, he was program manager for the GMT800 and L/N/P90 programs in Plant 7, chief manufacturing engineer for hydraulic steering in 1994, and staff engineer for integral gears in 1992. Following a number of assignments that included plant engineer, process engineer, advanced manufacturing engineer, and assistant staff engineer, he served as the value stream manager for steering valves at Plant 7 in 1988. He obtained a bachelor's degree in mechanical engineering from Iowa State University, the U.S., in May 1978, and a master of science from Purdue University, Indiana, the U.S., in May 1983.

**OWENBY, Douglas E.**, aged 55, joined our Company as our deputy chief operating officer of the North America division in June 2013, and was appointed as our vice president, chief operating officer of the Saginaw division in August 2013. He is responsible for developing and executing the business plan of the Saginaw division, negotiating commitments from the business lines, leveraging corporate functions to meet the business plan and the overall financial position of the Saginaw division. Mr. OWENBY has approximately 28 years of relevant experience in the automotive industry. He is also a member of NSC. Prior to joining our Group, Mr. OWENBY was the president and general manager of Benteler Automotive Corporation from February 2012 to June 2013. He also held various positions in BorgWarner, Inc. Including vice president and general manager of control systems business units from May 2009 to October 2011, vice president of global operations torque transfer systems from October 2005 to May 2009 and vice president of four-wheel drive operations from March 2003 to October 2005. From June 2000 to March 2003, Mr. OWENBY was vice president of operations and general manager of Bombardier Inc. From August 1997 to June 2000, he was a plant manager at the torque control products division of Eaton Corporation. From 1984 to 1996, he was with the steering division of Delphi Automotive Systems. Mr. OWENBY obtained a Bachelor of Science degree from Saginaw Valley State College, the U.S., in December 1986.

## DIRECTORS AND SENIOR MANAGEMENT

**LIU, Tao (柳濤)**, aged 51, was appointed as our vice president and chief operating officer of China division in August 2013. He is responsible for the business plan, the overall financial position and advising on strategic direction of the China division of our Group. Mr. LIU has approximately 18 years of relevant experience in the automotive industry. He is also a member of NSC. From May 2012 to July 2013, Mr. LIU was an executive director of the China division, where he was responsible for the business plan and the overall financial position of the China division. He served as the China operations manager and executive director of China operations from October 2009 to May 2012 and managing director of Saginaw Steering (Suzhou) Co., Ltd. from February 2008 to October 2009. Prior to this, Mr. LIU worked at Delphi Automotive Systems (China) Holding Co., Ltd., where he served as China operations manager of Delphi Steering, responsible for the manufacturing facilities in Suzhou and overseeing manufacturing operations of the China division from 2006 to 2008. He served as general manager of China operations of Metaldyne Powertrain Group from January 2005 to May 2006, and was the Asia Pacific Delphi manufacturing system manager of energy, chassis and steering system and a manufacturing manager of Delphi Shanghai Dynamics & Propulsion Systems Co., Ltd. from 2001 to 2004 and from 1997 to 2001 respectively. He also worked at Shanghai Machine Tool Works Plant from August 1987 to December 1996. Mr. LIU obtained a bachelor's degree in industrial automation from Tsinghua University, China, in 1987 and a master's degree in business administration from Purdue University, the U.S., in 2001.

**DECKER, Mark P.**, aged 48, was appointed as our vice president and chief human resources officer in September 2013. He is responsible for all global human resources activities. Mr. DECKER has approximately 23 years of relevant experience in the automotive industry. Mr. DECKER formerly served as vice president of human resources at Fisker Automotive, Inc. Prior to this, Mr. DECKER served as vice president of human resources at Meridian Automotive Systems, Inc. since August 2006. Mr. DECKER held various positions in Visteon Corporation, including human resources director from October 2005 to July 2006, senior manager of human resources from July 2003 to September 2005, director of human resources (Asia Pacific operations) from October 2001 to July 2003 and manager of human resources (Nashville glass plant) from April 2001 to October 2001. He was with Ford Motor Company from May 1992 to April 2000, where he served as employee relations associate from May 1992 to April 1996, human resource associate from April 1996 to January 1997, human resource manager of Atlanta parts distribution center from January 1997 to April 1998, corporate compensation planning associate from April 1998 to April 1999, project manager of human resources reengineering from May 1999 to November 1999 and human resource manager of manufacturing and plant engineering in powertrain operations from November 1999 to April 2000. Mr. DECKER obtained a master of arts degree in industrial relations from Wayne State University, the U.S., in May 1992 and a bachelor of science degree in business administration from Central Michigan University in May 1990.

### RELATIONSHIPS BETWEEN DIRECTORS AND SENIOR MANAGEMENT

None of the Directors or Senior Managers is related to any other Director or Senior Manager.

# DIRECTORS' REPORT

The Directors are pleased to present their report together with the consolidated financial statements for the year ended December 31, 2015 (Consolidated Financial Statements).

## CORPORATE INFORMATION AND GLOBAL OFFERING

The Company was incorporated in the Cayman Islands on August 21, 2012 as an exempted company with limited liability under the Companies Laws of the Cayman Islands (the Companies Law). The Company's shares (the Shares) were listed on the Hong Kong Stock Exchange on October 7, 2013.

## PRINCIPAL ACTIVITIES

The Group develops, manufactures, and supplies advanced steering and driveline systems to OEMs throughout the world.

## BUSINESS REVIEW

A review of the business of the Group for the year ended December 31, 2015 and a discussion on the Group's future prospects are provided in the Management Discussion and Analysis on pages 22 through 29 and in the Chairman's Statement on pages 20 through 21. An analysis of the Group's performance during the year using financial key performance indicators is provided within the Financial Highlights on pages 18 through 19. In addition, discussions on the Group's key policies, relationships with its key stakeholders and compliance with relevant laws and regulations which have a significant impact on the Group are contained in the Corporate Governance Report on pages 54 through 64 and in this Director's Report.

## KEY RISKS AND UNCERTAINTIES

The Group's financial condition, results of operations, businesses and prospects may be affected by a number of risks and uncertainties. The following are the key risks and uncertainties identified by the Group. There may be other risks and uncertainties in addition to those shown below which are not known to the Group or which may not be material now but could turn out to be material in the future.

### Operational Risk

Operational risk is the risk of loss resulting from inadequate or failed internal processes, people and systems or from external events. Responsibility for managing operational risks basically rests with every function at divisional and department levels. The Group recognises that operational risks cannot be eliminated completely and that it may not always be cost effective to do so.

Key functions in the Group are guided by their standard operating procedures, limits of authority and reporting framework. Functions such as, but not limited to, Internal Audit and Internal Control have the responsibility for providing assurance on the internal control framework. Key operational risk exposures are communicated to senior management as early as possible so that appropriate risk response can be taken.

### Financial Risk

In the course of business activities, the Group is exposed to a variety of financial risks, including market, liquidity and credit risks. The currency environment, interest rate cycles and mark to market value of investment securities may pose significant risks to the Group's financial condition, results of operations and businesses. The financial risk management objectives and policies of the Group can be found in note 3 to the Consolidated Financial Statements.

**DIRECTORS' REPORT****Business Risks***Cyclical industry and a decline in production levels*

Our sales are driven by the number of vehicles produced by the automotive manufacturers, which is ultimately dependent on consumer demand. The automotive industry is cyclical and sensitive to general economic conditions, including the global credit markets, interest rates, consumer credit, and consumer spending and preferences. Automotive sales and production can also be affected by the age of the vehicle fleet and related scrappage rates, labor relation issues, fuel prices, regulatory requirements, government initiatives, trade agreements, restructuring actions of our customers and suppliers, increased competition, and other factors.

*Loss of business or lack of commercial success*

Purchase orders generally provide for the supply of a customer's annual requirements for a particular vehicle model, and in some cases, for the supply of a customer's requirements for the life of a particular vehicle model, rather than for the purchase of a specific quantity of products. Lack of commercial success could reduce our sales or margins and thereby adversely affect our financial condition, operating results and cash flows.

*Inability to achieve product cost reductions*

In negotiation with the customers, customers tend to demand price reduction over the life of a vehicle model. We also bear significant responsibility on the product design, development and manufacturing engineering. Our financial performance is largely dependent on our ability to achieve product cost reductions through product design enhancement and manufacturing efficiencies. If we fail to achieve cost reductions, it would adversely affect our financial condition, operating results and cash flows.

*Increase in costs and restrictions on availability of raw materials*

Raw material, energy, and commodity costs can be volatile. If the costs of raw materials, energy, commodities, and product components increase or the availability thereof is restricted, it could adversely affect our financial condition, operating results, and cash flows.

*Substantial international operations*

As a result of our global presence, a significant portion of our revenues and expenses are denominated in currencies other than the U.S. dollar. International operations are subject to certain risks inherent in doing business abroad, including exposure to local economic conditions; political, economic, and civil instability and uncertainty; labor unrest; currency exchange rate fluctuations and the ability to hedge currencies; and increases in working capital requirements related to long supply chains.

*Highly competitive industry and efforts by our competitors to gain market share*

We operate in a highly competitive industry, and our competitors are seeking to expand market share with new and existing customers. Our competitors' efforts to grow market share could create downward pressure on our product pricing and margins. If we are unable to differentiate our products or maintain a low-cost footprint, we may lose market share or be forced to reduce prices, lowering our margins. Any such occurrence could adversely affect our financial condition, operating results, and cash flows.

*Our existing indebtedness and the inability to access capital markets*

As at December 31, 2015, we had approximately US\$641.7 million of outstanding indebtedness, as well as US\$296.2 million available loan credit not yet drawn under our revolving credit facility. The debt instruments governing our indebtedness contain covenants that may restrict our business activities or our ability to execute our strategic objectives, and our failure to comply with these covenants could result in a default under our indebtedness. Additionally, any downgrade in the ratings that rating agencies assign to us and our debt may ultimately impact our access to capital markets. Our inability to generate sufficient cash flow to satisfy our debt and lease obligations, to refinance our debt obligations or to access capital markets on commercially reasonable terms could adversely affect our financial condition, operating results, and cash flows.



## DIRECTORS' REPORT

### *Impairment charges relating to our long-lived assets*

We regularly monitor our long-lived assets for impairment indicators. In the event that we determine that our long-lived assets are impaired, we may be required to record a significant charge to earnings that could adversely affect our financial condition or operating results.

### *Significant product liability lawsuit or warranty claim*

In the event that our products fail to perform as expected, whether alleged or due to an actual fault, we may be subject to product liability lawsuits and other claims or we may be required by our customers to participate in a recall or other corrective action involving such products. We have also entered into agreements with certain customers where these customers may pursue claims against us for all or a portion of the amounts sought in connection with a product liability and warranty claims. We carry insurance for certain product liability claims, but such coverage may be limited. These types of claims could adversely affect our financial condition, operating results, and cash flows.

### *Environmental laws and regulations*

Our manufacturing facilities are subject to numerous laws and regulations designed to protect the environment. If we fail to comply with present and future environmental laws and regulations, we could be subject to future liabilities, which could adversely affect our financial condition, operating results, and cash flows.

### **Strategic Objectives Risk**

Our financial performance depends, in part, on our ability to successfully execute our strategic objectives. Our strategy is to deliver superior long-term shareholder value by growing our business through investments and improving our competitive position, while maintaining a strong balance sheet and returning cash to our shareholders. Our failure to execute our strategic objectives could adversely affect our financial condition, operating results, and cash flows.

### **Joint Venture Partners Risk**

Some of the businesses of the Group are conducted through non-wholly-owned subsidiaries, associates, joint ventures and joint operations in which the Group shares control with the joint venture partners. There is no assurance that any of these joint venture partners will continue their relationships with the Group in the future or their goals or strategies are in line with the Group. Such joint venture partners may have business interests or goals which are different from the Group. They may experience financial and other difficulties or may be unable to fulfil their obligations under the joint ventures which may affect the Group's businesses and operations.

## **FINAL DIVIDEND**

The Board recommends the payment of a final dividend of US\$41.1 million, representing 20% of net profit, or US\$0.016 per Share for the year ended December 31, 2015 subject to the approval of the Shareholders at the forthcoming annual general meeting of the Company (AGM).

The payment shall be made in US dollars, except that payment to Shareholders whose names appear on the register of members in Hong Kong shall be paid in Hong Kong dollars. The relevant exchange rate shall be the opening buying rate of Hong Kong dollars to US dollars as announced by the Hong Kong Association of Banks ([www.hkab.org.hk](http://www.hkab.org.hk)) on the day of the approval of the distribution at the AGM.

## **DISTRIBUTABLE RESERVES**

As at December 31, 2015, the Company's reserves available for distribution, calculated in accordance with the provisions of the Companies Law, amounted to approximately US\$686.5 million (as at December 31, 2014: US\$728.5 million).

## **SHARE CAPITAL**

Details of movements in the share capital of the Company during the year ended December 31, 2015 are set out in note 34 to the Consolidated Financial Statements.

## **PRE-EMPTIVE RIGHTS**

There are no provisions for pre-emptive rights under the articles of association of the Company (Articles of Association) or the laws of the Cayman Islands that would oblige the Company to offer new Shares on a pro-rata basis to existing Shareholders.

## **EQUITY-LINKED AGREEMENTS**

Details of the share options granted in prior years and current year are set out in note 25 of the Consolidated Financial Statements and 'Share options' section contained in this Directors' Report. For the share options granted during the year ended December 31, 2015, no shares were issued during the year. Except as disclosed above, the Company has not entered into any equity-linked agreements for the year ended December 31, 2015.

## **ENVIRONMENTAL, SOCIAL AND GOVERNANCE (ESG) SUMMARY**

The Group is committed to conducting our business in an environmentally sound manner and intends to adopt the Environment, Social and Governance Reporting Guide as required by The Rules Governing the Listing of Securities on The Stock Exchange of Hong Kong Limited (the Listing Rules). The Board will set out policies and ensure the Company will comply with the relevant laws and regulations that have a significant impact on the Company in relation to the environment, employment, labor and operation. In addition to carrying out the corporate-wide programs the Company has initiated, all of our employees are required to be familiar with environmental laws and regulations relevant to their employment responsibilities and to comply with them.

## **CHARITABLE DONATIONS**

During 2015, the charitable contributions and other donations made globally amounted to US\$0.6 million.

In 2015, our employees volunteered more than 9,100 hours of time supporting local charitable efforts and creating brand awareness through the Company's philanthropic activities.

## DIRECTORS' REPORT

### DIRECTORS

The Directors in office during the year ended December 31, 2015 and as at the date of this Annual Report were as follows:

#### Executive Directors

ZHAO, Guibin (趙桂斌) (*Chairman*)  
 RICHARDSON, Michael Paul  
 FAN, Yi (樊毅)

#### Non-Executive Directors

LU, Daen (錄大恩)  
 WANG, Xiaobo (王曉波)

#### Independent Non-Executive Directors

TSANG, Hing Lun (曾慶麟)  
 LIU, Jianjun (劉健君)  
 WEI, Kevin Cheng (蔚成)

Further details of the Directors are set forth in the section headed 'Directors and Senior Management' in this Annual Report.

Pursuant to Article 16.2 of the Articles of Association, any Director appointed by the Board, either to fill a casual vacancy or as an addition to the existing Directors, shall hold office only until the next following AGM of the Company and shall then be eligible for election at that meeting.

Pursuant to Article 16.18 of the Articles of Association, at every AGM one-third of the Directors for the time being shall retire from office by rotation provided that every Director shall be subject to retirement by rotation at least once every three years.

Accordingly, three Directors, namely, RICHARDSON, Michael Paul, LU, Daen, and WEI, Kevin Cheng, indicated that they intend to retire at the forthcoming AGM. All of the retiring Directors, being eligible, will offer themselves for re-election at the forthcoming AGM.

### CHANGES TO INFORMATION IN RESPECT OF DIRECTORS

Except as disclosed in the section headed 'Directors and Senior Management' in this Annual Report, there was no change to any of the information required to be disclosed in relation to any Director pursuant to paragraphs (a) to (e) and (g) of Rule 13.51(2) of the Listing Rules since the publication of the 2015 interim report of the Company.

### SERVICE CONTRACTS OF DIRECTORS

#### Executive Directors

Each of the Executive Directors has entered into a service contract with the Company pursuant to which they agreed to act as Executive Directors for a term of three years with effect from June 15, 2013, which shall be renewed as determined by the Board or the Shareholders of the Company. The appointment of each of the Executive Directors may be terminated by either party by giving at least three months' written notice to the other.

#### Non-Executive Directors

Each of the Non-executive Directors has entered into a service contract with the Company pursuant to which they agreed to act as a Non-executive Director for a term of three years with effect from September 20, 2013, which shall be renewed as determined by the Board or the Shareholders of the Company. The appointment of each of the Non-executive Directors may be terminated by either party by giving at least three months' written notice to the other.

## DIRECTORS' REPORT

### Independent Non-Executive Directors

Each of the Independent Non-executive Directors has been appointed for a term of three years commencing from June 15, 2013, which shall be renewed as determined by the Board or the Shareholders of the Company. The appointment of each of the Independent Non-executive Directors may be terminated by either party giving at least three months' written notice to the other.

All of the appointments of Directors are subject to the provisions of the Articles of Association with regard to vacating the office of Directors, removal and retirement by rotation of Directors. Except for directors' fees, none of the Independent Non-executive Directors is expected to receive any other remuneration for holding their office as an Independent Non-executive Director.

None of the Directors who is proposed for re-election at the forthcoming AGM has or is proposed to have a service contract that is not determinable by the Company within one year without the payment of compensation (other than statutory compensation).

### DIRECTORS' INTERESTS IN TRANSACTIONS, ARRANGEMENTS AND CONTRACTS

There were no transactions, arrangements and significant contracts with any member of the Group as the contracting party and in which the Directors and the Directors' connected party possessed direct or indirect substantial interests, and which was still valid on December 31, 2015 or any time during such year and related to the business of the Group.

### DIRECTORS' INTERESTS IN COMPETITIVE BUSINESS

During the year ended December 31, 2015, none of the Directors is considered to have interest in a business which competes or is likely to compete, either directly or indirectly, with the business of the Group.

### PERMITTED INDEMNITY

Article 33 of the Articles of Association provides that every Director shall be indemnified out of the assets of the Company against any liability, action, proceeding, claim, demand, costs, damages or expenses, including legal expenses, whatsoever which they or any of them may incur as a result of any act or failure to act in carrying out their functions other than such liability (if any) that they may incur by reason of their own actual fraud or willful defaults. The Company has arranged for appropriate insurance coverage in respect of potential legal actions against its Directors and senior management.

### PRINCIPAL SUBSIDIARIES

The Group's operations are conducted on a global basis through its direct or indirect subsidiaries. Details of the subsidiaries of the Company as at December 31, 2015 are set out in note 35 to the Consolidated Financial Statements.



## DIRECTORS' REPORT

### MAJOR CUSTOMERS AND SUPPLIERS

During the year ended December 31, 2015, the percentage of purchases attributable to the Group's major suppliers is as follows:

- the largest supplier: 9.5%
- five largest suppliers in aggregate: 26.1%

During the year ended December 31, 2015, the percentage of sales attributable to the Group's major customers is as follows:

- the largest customer: 47.7%
- five largest customers in aggregate: 89.8%

As far as the Company is aware, none of the Directors nor any of his associates and none of the Shareholders possessing over 5% of the interest in the share capital of the Company possessed any interest in the abovementioned suppliers and customers.

### SHARE OPTION SCHEME

Pursuant to an ordinary resolution passed on June 5, 2014, the Company adopted a share option scheme (the Share Option Scheme).

#### 1. Purpose

The purposes of the Share Option Scheme are: (1) to align the interests of the Company's Directors and senior management with the Company's performance and strategic objectives so as to lay a foundation for the Company's future development and maximise the shareholders' value; and (2) to attract, retain and motivate employees in key positions required for attaining the Company's strategic objectives by offering competitive general remuneration in the human resources market.

#### 2. Participants

The Board may, at their discretion, invite any Directors (excluding Independent Non-executive Directors), senior management, as well as other key employees approved by the Board (which means those who are responsible for the decision-making, operation and management of the Company) as the Participants (as defined under the Share Option Scheme).

**DIRECTORS' REPORT****3. Maximum number of shares subject to Options (as defined under the Share Option Scheme)**

- (a) The shares which may be issued upon exercise of all Options to be granted under the Share Option Scheme and any other share option scheme(s) adopted by the Company (and to which the provisions of Chapter 17 of the Listing Rules are applicable) must not in aggregate exceed 10% of the aggregate of the shares in issue on the date of adoption of the Share Option Scheme (the Scheme Mandate Limit) which shall be 249,780,400 shares.
- (b) The Company may refresh the Scheme Mandate Limit at any time subject to prior approval of the shareholders in general meeting and/or such other requirements prescribed under the Listing Rules from time to time. However, the Scheme Mandate Limit as refreshed shall not exceed 10% of the shares in issue as at the date of the aforesaid approval by the shareholders in general meeting. Options previously granted under the Share Option Scheme and any other share option schemes of the Company (and to which the provisions of Chapter 17 of the Listing Rules are applicable) (including those outstanding, cancelled or lapsed in accordance with its terms or exercised), shall not be counted for the purpose of calculating the limit as refreshed.
- (c) The Company may also seek separate approval of the Shareholders in a general meeting to grant Options beyond the Scheme Mandate Limit to Participants specifically identified by the Company before the aforesaid shareholders' meeting at which such approval is sought.
- (d) Subject to the requirements of the Listing Rules, the number of securities may be issued upon the exercise of all outstanding Options granted under the Share Option Scheme and any other schemes shall not exceed 30% of the relevant class of securities in issue of the Company (or its related subsidiaries) from time to time.
- (e) Unless approved by the Shareholders in the manner set out in this paragraph, the total number of Shares issued and to be issued upon exercise of the Options granted and to be granted under the Share Option Scheme of the Company to each Participant (including both exercised and outstanding Options) in any 12 month period shall not exceed 1% of the total number of Shares in issue (the Individual Limit). Any further grant of Options to a Participant which would result in the Shares issued and to be issued upon exercise of all Options granted and to be granted to such Participant (including exercised, cancelled and outstanding Options) in the 12 month period up to and including the date of such further grant exceeding the Individual Limit shall be subject to separate approval of the Shareholders in general meeting with such Participant and his associates abstaining from voting.
- (f) Each grant of Options to any Director, chief executive or substantial shareholder of the Company (or any of their respective associates) shall be subject to the prior approval of the Independent Non-Executive Directors of the Company. Where any grant of Options to a substantial shareholder, or any of its respective associates, would result in the number of shares issued and to be issued upon exercise of all Options already granted and to be granted (including Options exercised, cancelled and outstanding) to such person in the 12 month period up to and including the date of such grant:
  - (i) Representing in aggregate over 0.1% (or such other higher percentage as may from time to time be specified by the Hong Kong Stock Exchange) of the shares in issue; and
  - (ii) Having an aggregate value, based on the closing price of the Shares as stated in the daily quotations sheets issued by the Hong Kong Stock Exchange on the date on which the Board resolves to make an Offer (as defined under the Share Option Scheme) of that Option to the Participant or such other date as designated by the Board (the Date of Grant), in excess of HK\$5 million (or such other higher amount as may from time to time be specified by the Hong Kong Stock Exchange), such further grants of Options shall be subject to the prior approval by the shareholders (voting by way of poll) in general meeting. The Company shall send a circular to the shareholders in accordance with the Listing Rules and all connected persons (as defined in the Listing Rules) of the Company shall abstain from voting in favour of the resolution at such general meeting.

## DIRECTORS' REPORT

### 4. **Acceptance period**

A Share Option may be accepted by a Participant within a certain number of days from the date of the offer of the grant of the Option as indicated in the offer.

### 5. **Exercise period**

The period within which the Options may be exercised must expire no later than 10 years from the relevant Date of Grant.

### 6. **Minimum holding period**

The Option must be held for one year from the Date of Grant before it can be exercised. The vesting period shall be three years and one-third shall be vested at each anniversary from the Date of Grant.

### 7. **Consideration for acceptance**

The consideration payable for acceptance of the Option of grant by each Participant is HK\$1.00. If the Participant does not accept such grant of Option pursuant to the procedures specified in the respective grant agreement or notice within the stipulated timeframe, such Option shall be regarded as unaccepted and lapsed.

### 8. **Subscription Price**

The Subscription Price (as defined under the Share Option Scheme) shall be such price determined by the Board in its absolute discretion and notified to the Participant in the Offer and shall be no less than the higher of:

- (a) the closing price of a share as stated in the daily quotations sheet issued by the Hong Kong Stock Exchange on the Date of Grant;
- (b) the average closing price of the shares as stated in the daily quotations sheets issued by the Hong Kong Stock Exchange for the five business days immediately preceding the Date of Grant; or
- (c) the nominal value of a share.

## DIRECTORS' REPORT

9. The Share Option Scheme will remain in force for a period of 10 years commencing on the date on which the Share Option Scheme was adopted and has a remaining term of approximately 8 years as at the date of this report.

The summary of the Options granted under the Share Option Scheme that were still outstanding as at December 31, 2015 are as follows:

	Grant date	Options granted	Options held at January 1, 2015	Options granted during the year	Options exercised during the year	Options cancelled/lapsed during the year	Options held at December 31, 2015	Exercise period <sup>(1)</sup>	Exercise price per share	Share price on the grant date <sup>(2)</sup>	Share price on the exercise date <sup>(3)</sup>
<b>Director</b>											
ZHAO, Guibin	June 11, 2014	1,667,970	1,667,970	-	-	-	1,667,970	June 11, 2014– June 10, 2024	5.15	5.15	N/A
	June 10, 2015	1,667,970	-	1,667,970	-	-	1,667,970	June 10, 2015– June 9, 2025	8.61	8.48	N/A
FAN, Yi	June 11, 2014	526,730	526,730	-	-	-	526,730	June 11, 2014– June 10, 2024	5.15	5.15	N/A
	June 10, 2015	526,730	-	526,730	-	-	526,730	June 10, 2015– June 9, 2025	8.61	8.48	N/A
LU, Daen	June 11, 2014	351,150	351,150	-	-	-	351,150	June 11, 2014– June 10, 2024	5.15	5.15	N/A
	June 10, 2015	351,150	-	351,150	-	-	351,150	June 10, 2015– June 9, 2025	8.61	8.48	N/A
WANG, Xiaobo	June 11, 2014	351,150	351,150	-	-	-	351,150	June 11, 2014– June 10, 2024	5.15	5.15	N/A
	June 10, 2015	351,150	-	351,150	-	-	351,150	June 10, 2015– June 9, 2025	8.61	8.48	N/A
Sub-total		5,794,000	2,897,000	2,897,000	-	-	5,794,000				
<b>Senior Management</b>											
BRESSON, Laurent Robert <sup>(4)</sup>	June 11, 2014	2,633,650	2,633,650	-	-	-	2,633,650	June 11, 2014– June 10, 2024	5.15	5.15	N/A
	June 10, 2015	2,633,650	-	2,633,650	-	-	2,633,650	June 10, 2015– June 9, 2025	8.61	8.48	N/A
Senior Management (in aggregate)	June 11, 2014	5,706,210	5,003,910	-	(673,040)	(1,697,230)	2,633,640	June 11, 2014– June 10, 2024	5.15	5.15	8.40
	June 10, 2015	4,828,340	-	4,828,340	-	(2,019,120)	2,809,220	June 10, 2015– June 9, 2025	8.61	8.48	N/A
Sub-total		15,801,850	7,637,560	7,461,990	(673,040)	(3,716,350)	10,710,160				
Total		21,595,850	10,534,560	10,358,990	(673,040)	(3,716,350)	16,504,160				

## Notes:

- (1) The Options granted in 2014 and 2015 must be held for one year from June 11, 2014 and June 10, 2015, respectively. The Options are exercisable subject to, amongst other relevant vesting criteria, the vesting schedule of one-third at each anniversary of the date of grant of share options.
- (2) The Exercise Price for the options granted on June 11, 2014 was the closing price of the shares quoted on the Stock Exchange on the trading day on the date of the grant of the Options. The closing price of the shares of the Company immediately before the date of the grant (i.e. June 10, 2014) was HK\$5.07. The Exercise Price for the options granted on June 10, 2015 was the average closing price for five consecutive trading days prior to the date of the grant. The closing price of the shares of the Company immediately before the date of the grant (i.e. June 9, 2015) was HK\$8.25.
- (3) Options were exercised during the year ended December 31, 2015.
- (4) Mr. BRESSON, Laurent Robert is the President and Global Chief Operating Officer of the Company.



## DIRECTORS' REPORT

### PENSION SCHEMES

The Group has both defined contribution and defined benefit plans. Various subsidiaries within the Group operate various pension schemes. The schemes are generally funded through payments to insurance companies or trustee administered funds, determined by periodic actuarial calculations.

More detailed information regarding pension schemes is set out in note 18 to the Consolidated Financial Statements.

### NON-COMPETITION UNDERTAKING FROM OUR CONTROLLING SHAREHOLDERS

On June 15, 2013, each of AVIC, AVIC Auto, PCM China and Nexteer Hong Kong (Nexteer Hong Kong, and together with AVIC, AVIC Auto and PCM China, the Controlling Shareholders) provided a non-competition undertaking (the Non-competition Undertaking), pursuant to which each of the Controlling Shareholders has unconditionally and irrevocably undertaken that apart from the Retained Business as defined in the prospectus of the Company dated September 24, 2013 (the Prospectus) it will not, and will procure its subsidiaries not to, whether directly or indirectly through third parties or the provision of support to such third parties, engage in any automotive steering systems and driveline systems business (the Core Business) that competes, or is likely to compete, directly or indirectly with our Group. Details of the Non-competition Undertaking were disclosed in the Prospectus under the section headed 'Relationship with our Controlling Shareholders'.

For the year ended December 31, 2015, the Group has not (1) pursued or declined any new business opportunity referred to us by the Controlling Shareholders nor (2) exercised or waived the pre-emptive rights under the Non-competition Undertaking. Each of the Controlling Shareholders has provided an annual confirmation of its compliance with the Non-competition Undertaking. The Independent Non-executive Directors have reviewed and were satisfied that each of the Controlling Shareholders has complied with the Non-competition Undertaking for the year ended December 31, 2015.

### CONTROLLING SHAREHOLDERS' INTERESTS IN CONTRACTS

There were no contracts of significance with any member of the Group as the contracting party and in which any of the Controlling Shareholders possessed direct or indirect substantial interests, and which was still valid on December 31, 2015 or any time during such year and related to the business of the Group.

## DIRECTORS' REPORT

## DIRECTORS' AND CHIEF EXECUTIVES' INTERESTS AND SHORT POSITIONS IN THE SHARES AND UNDERLYING SHARES

As at December 31, 2015, the interests or short positions of the Directors or chief executives of the Company in the Shares, underlying Shares and debentures of the Company or its associated corporations (within the meaning of Part XV of the Securities and Futures Ordinance (the SFO)) required to be notified to the Company and the Hong Kong Stock Exchange pursuant to Divisions 7 and 8 of Part XV of the SFO (including interest or short positions which they were taken or deemed to have under such provisions of the SFO), or which would be required, pursuant to section 352 of the SFO, to be entered in the register referred to therein, or which would be required to be notified to the Company and the Hong Kong Stock Exchange pursuant to Model Code for Securities Transactions by Directors of Listed Companies set out in Appendix 10 of the Listing Rules (the Model Code) are as follows:

### Interest in the Company

Name	Capacity	Nature of Interest	No. of underlying Shares of the Company held <sup>(1)</sup>	Approximate Percentage of Total Issued Shares %
ZHAO Guibin	Director and Chief Executive Officer	Beneficial owner	3,335,940(L)	0.13
WANG Xiao Bo	Director	Beneficial owner	702,300(L)	0.03
LU Daen	Director	Beneficial owner	702,300(L)	0.03
FAN Yi	Director	Beneficial owner	1,053,460(L)	0.04
BRESSON Laurent Robert	President and Global Chief Operating Officer	Beneficial owner	5,267,300(L)	0.21

Notes:

(1) These represent the interests in underlying Shares in respect of the Options granted by the Company.

(L) Denotes a long position in Shares.

Except as disclosed above, as at December 31, 2015, none of our Directors and chief executives of the Company has any interests or short positions in the shares, underlying shares or debentures of the Company or its associated corporations (within the meaning of Part XV of the SFO) which were (i) recorded in the register required to be kept under section 352 of the SFO, or (ii) otherwise notified to the Company and the Hong Kong Stock Exchange pursuant to the Model Code.

## DIRECTORS' RIGHTS TO ACQUIRE SHARES OR DEBENTURES

Save as disclosed above, no rights to acquire benefits by means of the acquisition of Shares in or debentures of the Company or any of its subsidiaries were granted to any Director or their respective spouse or children under 18 years of age, nor were any such rights exercised by them. Neither the Company nor any of its subsidiaries was a party to any arrangement to enable the Directors, or their respective spouse or children under 18 years of age, to acquire such rights in any other body corporate for the year ended December 31, 2015.

## DIRECTORS' REPORT

## SUBSTANTIAL SHAREHOLDERS' INTERESTS AND SHORT POSITIONS IN THE SHARES AND UNDERLYING SHARES

As at December 31, 2015, the following Shareholders (excluding the Directors and chief executives of the Company) had interests or short positions in any Shares and underlying Shares of the Company which will be required to be disclosed under provisions of Division 2 and 3 of Part XV of the SFO as recorded in the register required to be kept under Section 336 of the SFO:

Name	Capacity	No. of Shares	Approximate Percentage of Total Issued Shares %
Nexteer Automotive (Hong Kong) Holdings Limited (Nexteer Hong Kong) <sup>(1)</sup>	Beneficial Owner	1,680,000,000(L)	67.26%
Pacific Century Motors, Inc. (PCM China) <sup>(1)</sup>	Interest of controlled corporation	1,680,000,000(L)	67.26%
AVIC Automotive Systems Holding Co., Ltd. (AVIC Auto) <sup>(2)</sup>	Interest of controlled corporation	1,680,000,000(L)	67.26%
Aviation Industry Corporation of China (AVIC) <sup>(2)</sup>	Interest of controlled corporation	1,680,000,000(L)	67.26%
Mondrian Investment Partners Limited <sup>(3)</sup>	Investment Manager	158,380,002(L)	6.34%

Notes:

(L) Denotes a long position in Shares.

1: Nexteer Hong Kong is wholly-owned by PCM China, which is in turn owned as to 51% by AVIC Auto and as to 49% by Beijing E-Town International Automotive Investment & Management Co., Ltd. (北京亦莊國際汽車投資管理有限公司) (a directly wholly-owned subsidiary of Beijing E-Town). Each of PCM China and AVIC Auto is deemed to be interested in the 1,680,000,000 Shares held by Nexteer Hong Kong.

2: AVIC Auto is owned as to 70.11% by AVIC, 22.47% by China National Guizhou Aviation Industry Group Co. Ltd (中國貴州航空工業(集團)有限公司) and 7.42% by Beijing E-Town International Automotive Investment & Management Co. Ltd. (北京亦莊國際汽車投資管理有限公司). AVIC is deemed to be interested in the 1,680,000,000 Shares held by Nexteer Hong Kong.

3: Pursuant to the SFO, when a shareholder's shareholding in the Company changes, it is not necessary for the Shareholder to notify the Company and the Stock Exchange unless certain criteria are fulfilled, therefore substantial shareholders' latest shareholding in the Company may be different to the shareholding filed with the Company and the Stock Exchange.

## DIRECTORS' REPORT

## DISCLOSURE OF INTERESTS OF SUBSTANTIAL SHAREHOLDERS OF OTHER MEMBERS OF OUR GROUP

So far as our Directors are aware, as at December 31, 2015, the persons other than our Directors and our chief executive who were directly interested in 10% or more of the issued and outstanding share capital of our subsidiaries carrying rights to vote in all circumstances at general meetings of each relevant subsidiary, were as follows:

Member of our Group	Person with 10% or more interest (other than the Company)	Capacity	Percentage of the substantial shareholder's interest
Nexteer Lingyun Driveline (Zhuozhou) Co., Ltd.	Lingyun Industrial Co., Ltd.	Registered owner	40%
Nexteer Lingyun Driveline (Wuhu) Co., Ltd.	Lingyun Industrial Co., Ltd.	Registered owner	40%
Chongqing Nexteer Steering Systems Co., Ltd.	Chongqing Jianshe Industry (Group) Co., Ltd.	Registered owner	50%

Save as disclosed above, as at December 31, 2015, our Directors are not aware of any person who, as at December 31, 2015, was, directly or indirectly, interested in 10% or more of the nominal value of any class of share capital carrying voting rights to vote in all circumstances at general meetings of any other member of our Group.

## CONNECTED TRANSACTIONS

The Group's related parties transactions for the year ended December 31, 2015 set out in note 32 to the Consolidated Financial Statements constitute continuing connected transactions (as defined in Chapter 14A of the Listing Rules) and the Company has complied with the disclosure requirements in Chapter 14A of the Listing Rules.

### Continuing Connected Transactions which are Exempted from Reporting, Announcement and Independent Shareholders' Approval Requirements of the Listing Rules

#### *Guarantees from AVIC and Beijing E-Town*

By way of two loan agreements dated October 29, 2012, PCM (Singapore) Steering Holding Pte. Limited and PCM (US) Steering Holding Inc., both are direct wholly-owned subsidiaries of the Company, agreed to borrow US\$126.0 million and US\$300.0 million, respectively, from Export-Import Bank of China (the EXIM Guaranteed Bank Loans). The EXIM Guaranteed Bank Loans were intended to repay previous loans and fund certain acquisitions and operations of the Group, which shall be repaid in 14 installments which commenced in June 2014 and shall be fully settled in October 2020. The total amount of guarantees provided by AVIC and Beijing E-Town to our Group amounted to US\$426.0 million. The balance of the EXIM guaranteed bank loans as at December 31, 2015 was US\$304.0 million. AVIC and Beijing E-Town are substantial shareholders of the Company and therefore are connected persons under Rule 14A.07(1).

Such guarantees as well as the associated lower financing costs of the EXIM Guaranteed Bank Loans, being financial assistance provided by AVIC and Beijing E-Town to our Group, were for our benefit on normal commercial terms and no security over our assets was granted. Accordingly, such guarantees of the EXIM Guaranteed Bank Loans, are exempt from all reporting, announcement and independent shareholders' approval requirements pursuant to Rule 14A.90 of the Listing Rules.

Details of these guarantees were fully disclosed in the Prospectus under the section headed 'Connected Transactions'.



## DIRECTORS' REPORT

### **Continuing Connected Transactions which are Exempted from the Independent Shareholders' Approval Requirement, but subject to the Reporting, Annual Review and Announcement Requirements of the Listing Rules**

#### *Purchase Agreements with Yubei Steering Systems Co.,Ltd. (Yubei Steering)*

Reference is made to the prospectus of the Company dated September 2013 (the Prospectus) and the announcement of the Company dated December 29, 2015 (as supplemented by the announcement dated January 5, 2016) (collectively, the Announcements) in relation to the transactions between the Group and Yubei Steering (Yubei Transactions). Yubei Steering is indirectly held as to 49.93% by AVIC, one of the Company's controlling shareholders (as defined in the Listing Rules). As Yubei Steering is an associate of AVIC, pursuant to Chapter 14A of the Listing Rules, Yubei Steering is regarded as a connected person of the Company and the Yubei Purchase Agreements constitute continuing connected transactions of the Group under the Listing Rules.

Pursuant to three nomination letters accepted by Yubei Steering on June 5, 2013, Nexteer Automotive (Suzhou) Co., Ltd. (Nexteer Suzhou), an indirect wholly-owned subsidiary of the Company, agreed to purchase, and Yubei Steering agreed to supply, certain manual and rack and pinion gears for a term of three years commencing in 2013. Nexteer Suzhou and Yubei Steering are expected to enter into supplemental purchase agreements annually during the three-year term and Nexteer Suzhou will issue purchase orders from time to time (collectively, the Yubei Purchase Agreements).

As the annual cap for the Yubei Transactions for the year ended December 31, 2015 had been exceeded, the Group had approved a revised annual cap of RMB130 million for the year ended December 31, 2015. In addition, the Group had approved as a new annual cap of RMB81.5 million for the nine months ending September 30, 2016 (collectively, the New Annual Caps).

As the applicable percentage ratios (other than the profit ratio) set out in Rule 14.07 of the Listing Rules in respect of the New Annual Caps under the Yubei Purchase Agreements are more than 0.1% but less than 5%, pursuant to Rule 14A.76 of the Listing Rules, the Yubei Transactions are subject to the reporting, and announcement requirements, but are exempt from the circular and shareholders' approval requirements. The Yubei Transactions are also subject to the annual review requirements set out in Rule 14A.55 and Rule 14A.56 of the Listing Rules.

Details of the Yubei Purchase Agreements were fully disclosed in the Prospectus and the announcements of the Company dated December 29, 2015 and January 5, 2016.

Pursuant to Rule 14A.56 of the Listing Rules, the Board has engaged the auditor of the Company to perform review procedures on the aforesaid continuing connected transactions. Based on the work performed, the auditor of the Company had provided a letter to the Board confirming that the aforesaid continuing connected transactions:

- (i) Have been approved by the Directors;
- (ii) Were entered into in accordance with the pricing policies of the Group;
- (iii) Were entered into in accordance with the terms of the relevant agreements governing such transactions; and
- (iv) As announced by the Company on December 29, 2015, the aggregate value of the sales to Yubei Steering for the year ended December 31, 2015 exceeded the annual cap previously announced by the Company in the Prospectus. Therefore, the continuance of sales transactions in the year ended December 31, 2015 after the annual cap has been exceeded have not obtained prior Director approval.

A copy of the auditor's letter has been provided by the Company to the Hong Kong Stock Exchange.

Pursuant to Rule 14A.55 of the Listing Rules, the Independent Non-executive Directors have reviewed the above continuing connected transactions and confirmed that the transactions have been entered into:

- (i) In the ordinary and usual course of the business of the Group;
- (ii) On normal commercial terms; and
- (iii) According to the relevant agreements governing them on terms that are fair and reasonable and in the interests of the Shareholders of the Company as a whole.

**DIRECTORS' REPORT****PURCHASE, REDEMPTION OR SALE OF LISTED SECURITIES OF THE COMPANY**

For the year ended December 31, 2015, neither the Company nor any of its subsidiaries purchased, redeemed or sold any of the Company's listed securities.

**MANAGEMENT CONTRACTS**

No contracts concerning the management and administration of the whole or any substantial part of the business of the Group were entered into or existed for the year ended December 31, 2015.

**PUBLIC FLOAT**

The Company has maintained the public float as required by the Listing Rules up to the date of this Annual Report.

**PROFESSIONAL TAX ADVICE RECOMMENDED**

If the Shareholders of the Company are unsure about the taxation implications of purchasing, holding, disposing of, dealing in, or the exercise of any rights in relation to the Shares of the Company, they are advised to consult an expert.

**AUDITOR**

The Consolidated Financial Statements have been audited by PricewaterhouseCoopers, the Company's external auditor.

**CLOSURE OF REGISTER OF MEMBERS**

The Company's AGM will be held on June 6, 2016. For determining the entitlement to attend and vote at the AGM, the register of members of the Company will be closed from June 2, 2016 to June 6, 2016, both days inclusive, during which period no transfer of Shares will be registered. In order to be eligible to attend and vote at the AGM, all transfers accompanied by the relevant share certificates must be lodged with the Company's Share Registrar in Hong Kong, Computershare Hong Kong Investor Services Limited at Shops 1712-1716, 17th Floor, Hopewell Centre, 183 Queen's Road East, Wanchai, Hong Kong for registration no later than 4:30 p.m. on June 1, 2016.

The final dividend is payable on June 23, 2016 and the record date for entitlement to the proposed final dividend is June 15, 2016. For determining the entitlement to the proposed final dividend, the register of members of the Company will be closed from June 13, 2016 to June 15, 2016, both days inclusive, during which no transfer of Shares will be registered. In order to qualify for the proposed final dividend, all transfers accompanied by the relevant share certificates must be lodged with the Company's Share Registrar in Hong Kong, Computershare Hong Kong Investor Services Limited (address as per above) for registration no later than 4:30 p.m. on June 10, 2016.

On behalf of the Board

**Mr. ZHAO, Guibin**

*Chairman and Chief Executive Officer*

Hong Kong, March 15, 2016

# CORPORATE GOVERNANCE REPORT

## CORPORATE GOVERNANCE PRACTICES

The Company is committed to maintaining high standards of corporate governance. The Company recognises that sound corporate governance practices are fundamental to our effective and transparent operation and to our ability to protect the rights of the Shareholders and enhance shareholder value.

The Company has adopted its own Internal Control and Corporate Governance Policies, which are based on the principles, provisions and practices set out in the Corporate Governance Code and Corporate Governance Report (the Hong Kong CG Code) contained in Appendix 14 of the Listing Rules.

Except as expressly described below, in the opinion of the Directors, the Company has complied with all applicable code provisions set out in the Hong Kong CG Code throughout the year ended December 31, 2015.

### Chairman and Chief Executive Officer

A.2.1 – Mr. ZHAO Guibin, our chairman also acts as the Chief Executive Officer of the Company, which constitutes a deviation from Code Provision A.2.1 of the Hong Kong CG Code. The Board believes that this structure does not impair the balance of power and authority between the Board and the management of the Company or the Group, given that: (i) decisions made by our Board require approval by at least a majority of our Directors and that our Board includes three Independent Non-executive Directors out of a total of eight Directors, which is more than the Listing Rules requirement of one-third, and we believe there is sufficient check and balance in the Board; (ii) Mr. ZHAO and the other Directors are aware of and undertake to fulfill their fiduciary duties as Directors, which require, among other things, that each Director, including Mr. ZHAO, acts for the benefit and in the best interests of the Group and will make decisions for our Group accordingly; and (iii) the balance of power and authority is ensured by the operations of the Board which is comprised of experienced and high caliber individuals who meet regularly to discuss issues affecting the operations of the Group. Moreover, the overall strategic, financial and operational policies of the Group are made collectively after thorough discussion at both Board and senior management levels. The Board will continue to review the effectiveness of the corporate governance structure of the Group in order to assess whether separation of the roles of chairman and Chief Executive Officer is necessary.

The Chairman is responsible for providing leadership to, and overseeing the functioning of, the Board to ensure that it acts in the best interests of the Group and that Board meetings are planned and conducted effectively. The Chairman is responsible for setting the agenda for each Board meeting, taking into account, where appropriate, matters proposed by Directors and the Joint Company Secretaries.

With the support of the Executive Directors and the Joint Company Secretaries, the Chairman seeks to ensure that all Directors are properly briefed on issues arising at Board meetings and provided with adequate and accurate information in a timely manner. The Chairman promotes a culture of openness and actively encourages Directors to voice their opinion and be fully engaged in the Board's affairs so as to contribute to the Board's effective functioning. The Board, under the leadership of the Chairman, has adopted good corporate governance practices and procedures and has taken appropriate steps to provide effective communication with Shareholders and other stakeholders, as outlined later in the report.

The Company periodically reviews its corporate governance practices with reference to the latest development of the Hong Kong CG Code.

## CORPORATE GOVERNANCE REPORT

### COMPLIANCE WITH CODE OF CONDUCT REGARDING DIRECTORS' SECURITIES TRANSACTIONS

The Company has adopted the Model Code as set out in Appendix 10 of the Listing Rules as the Company's code of conduct regarding securities transactions by the Directors of the Company. Having made specific enquiry of all Directors, all Directors have confirmed that they complied with the required standards set out in the Model Code for the year ended December 31, 2015.

The Company has also adopted its own code of conduct regarding employees' securities transactions in terms no less exacting than the standard set out in the Model Code for the compliance by its relevant employees who are likely to be in possession of unpublished inside information of the Company in respect of their dealings in the Company's securities.

### THE BOARD OF DIRECTORS AND SENIOR MANAGEMENT

The Board is responsible for leadership and control of the Company and the Group and for promoting the success of the Group by directing and supervising the Group's affairs. In addition, the Board is responsible for overseeing the corporate governance and financial reporting of the Company and for reviewing the effectiveness of the Group's system of internal controls. To assist it in fulfilling its duties, the Board has established two board committees: the Audit and Compliance Committee and the Remuneration and Nomination Committee.

The Group is managed collectively by our core management team, which is comprised of Board and senior management of the Group. Members of our senior management are responsible for overseeing their respective functions and making day-to-day decisions of the Group. They meet regularly to discuss issues of their respective functions and make relevant decisions and report to our Board regularly and when necessary. Our senior management as a whole is also responsible for formulating the overall strategies, annual budget, key business, financial and other operational policies and preparing proposals of any key business, financial and other operational decisions of the Group taking into account inputs from different functions for the Board's approval. The Board will consult with our senior management on such proposals and discuss the same at the Board level with an aim to reach a consensus that is in the best interest of the Group. Once the key policies and decisions are formulated and made, our senior management as a whole will implement the same throughout the Group. Accordingly, the overall strategic and other key business, financial and operational policies and decisions of the Group are made collectively from its inception to implementation after thorough discussion at both Board and senior management levels.

The Board has established clear guidelines with respect to matters that must be approved or recommended by the Board, including, without limitation, approval and adoption of the Group's annual operating budget and capital expenditure budget; the hiring or dismissal of the Chief Executive Officer (the CEO), Chief Financial Officer (the CFO), Joint Company Secretaries or certain other members of the senior management team; and approving and recommending significant transactions. The Group has arranged for appropriate insurance coverage in respect of potential legal actions against its Directors and senior management.

#### Composition of the Board, Number of Board Meetings and Directors' Attendance

The Board consists of eight Directors, including three Executive Directors, namely ZHAO, Guibin (Chairman), RICHARDSON, Michael Paul and FAN, Yi, two Non-executive Directors namely LU, Daen and WANG, Xiaobo, and three Independent Non-executive Directors, namely TSANG, Hing Lun, LIU, Jianjun and WEI, Kevin Cheng. The biographical details of each Director and their respective responsibilities and dates of appointment are included in the section headed 'Directors and Senior Management' of this Annual Report. None of the Directors or chief executive is related to one another.



## CORPORATE GOVERNANCE REPORT

The following is the attendance record of the Directors at Board and committee meetings, and general meetings held for the year ended December 31, 2015:

Name of Director	Attendance/Number of Meetings in 2015				
	Board	Remuneration and Nomination Committee	Audit and Compliance Committee	Annual General Meeting	Extraordinary General Meeting
ZHAO, Guibin (趙桂斌)	4/4	N/A	N/A	1/1	1/1
RICHARDSON, Michael Paul	4/4	N/A	N/A	1/1	1/1
FAN, Yi (樊毅)	4/4	N/A	N/A	1/1	1/1
LU, Daen (錄大恩)	4/4	N/A	3/3	1/1	1/1
WANG, Xiaobo (王曉波)	4/4	2/2	N/A	1/1	1/1
TSANG, Hing Lun (曾慶麟)	4/4	2/2	3/3	1/1	1/1
LIU, Jianjun (劉健君)	4/4	2/2	N/A	1/1	1/1
WEI, Kevin Cheng (蔚成)	4/4	N/A	3/3	1/1	1/1

### PRACTICES AND CONDUCT OF MEETINGS

Notice of regular Board meetings is given to all Directors at least 14 days in advance, and reasonable notice is generally given for other Board meetings. Annual meeting schedules and the draft agenda of each meeting are normally made available to Directors in advance. Arrangements are in place to allow Directors to include items in the agenda, and final agendas together with relevant supporting documents are sent to Directors at least 3 days before each regular Board meeting, and as soon as practicable before other Board meetings, so that the Board can make informed decisions on matters placed before it. Each Director also has separate and independent access to the senior management where necessary. Minutes of the Board meetings are kept by the Joint Company Secretary. Draft minutes are circulated to Directors for comment within a reasonable time after each meeting.

If a Director or any of his associates has a material interest in a transaction, that Director is required to abstain from voting and not to be counted in the quorum at the meeting for approving the transaction.

### INDEPENDENCE OF INDEPENDENT NON-EXECUTIVE DIRECTORS

During the year ended December 31, 2015, the Board at all times met the requirements of the Listing Rules relating to the appointment of at least three Independent Non-executive Directors representing one-third of the Board with one of whom possessing appropriate professional qualifications or accounting or related financial management expertise.

The Company has received written confirmation from each of the Independent Non-executive Directors in respect of his independence in accordance with the independence guidelines set out in Rule 3.13 of the Listing Rules. The Company considers all Independent Non-executive Directors to be independent.

### APPOINTMENT AND RE-ELECTION OF DIRECTORS

The Company uses a formal and transparent procedure for the appointment, election and removal of Directors, which is set out in the Company's Articles of Association and is led by the Remuneration and Nomination Committee, which will make recommendations on appointment of new Directors to the Board for approval.

Further details relating to the appointment, election and removal of Directors and the service contracts of Directors are set out in the sections headed 'Directors' and 'Service Contracts of Directors' in the Directors' Report included in this Annual Report.

## CORPORATE GOVERNANCE REPORT

**CONTINUOUS PROFESSIONAL DEVELOPMENT OF DIRECTORS**

Each newly appointed Director receives a comprehensive introduction to the Company in order to ensure his understanding of the business and operations of the Group and awareness of a director's responsibilities and obligations. All Directors are encouraged to participate in continuous professional development to develop and refresh their knowledge by attending internal in-house training and external seminars. For the year ended December 31, 2015, the Company arranged in-house training for all Directors relating to ongoing compliance obligations, corporate governance and other related topics. In compliance with Rule 3.29 of the Listing Rules, Mr. FAN, our Executive Director and Joint Company Secretary, has undertaken not less than 15 hours of relevant professional training during the year ended December 31, 2015.

During the year ended December 31, 2015, the Directors participated in the following training:

Directors	Types of training
<b>Executive Directors</b>	
ZHAO, Guibin ( <i>Chairman</i> )	A,B,C,D
RICHARDSON, Michael Paul	A,B,C,D
FAN, Yi	A,C,D
<b>Non-Executive Directors</b>	
LU, Daen	A,B,C,D
WANG, Xiaobo	A,B,C,D
<b>Independent Non-Executive Directors</b>	
TSANG, Hing Lun	A,B,C,D
LIU, Jianjun	A,B,C,D
WEI, Kevin Cheng	A,C,D

A: attending seminars and/or conferences and/or forums

B: giving talks at seminars and/or conferences and/or forums

C: attending in-house training relating to the ongoing compliance obligations, corporate governance and other related topics

D: reading newspapers, journals, Company's newsletters and updates relating to the economy, general business, automotive component manufacturing industry or Directors' duties and responsibilities, etc.

**COMMITTEES**

The Board has established the Audit and Compliance Committee, and the Remuneration and Nomination Committee for overseeing particular aspects of the Group's affairs. All Board committees are established with defined written terms of reference which are posted on the Company's website, the Hong Kong Stock Exchange's website and are available to Shareholders upon request. Meetings of the Board committees generally follow the same procedures as meetings of the Board.

## CORPORATE GOVERNANCE REPORT

### THE AUDIT AND COMPLIANCE COMMITTEE

The Board established an Audit and Compliance Committee on June 15, 2013 with written terms of reference in compliance with Rule 3.21 of the Listing Rules and paragraph C.3 and paragraph D.3 of the Hong Kong CG Code. The Audit and Compliance Committee consists of three members, comprising WEI, Kevin Cheng, TSANG, Hing Lun and LU, Daen. All members of the Audit and Compliance Committee are Non-executive Directors, among whom TSANG, Hing Lun and WEI, Kevin Cheng are Independent Non-executive Directors. The chairman of the Audit and Compliance Committee is WEI, Kevin Cheng who holds the appropriate professional qualifications as required under Rules 3.10(2) and 3.21 of the Listing Rules. The primary duties of the Audit and Compliance Committee include, without limitation, assisting our Board by providing an independent view of the effectiveness of the financial reporting process, risk management and internal control systems of the Group, overseeing the audit process and performing other duties and responsibilities as assigned by the Board.

The Board recognises that corporate governance should be the collective responsibility of Directors and delegates the corporate governance duties to the Audit and Compliance Committee which include:

- reviewing and monitoring the Group's policies and practices on compliance with legal and regulatory requirements;
- developing, reviewing and monitoring the code of conduct and compliance manual (if any) applicable to employees and Directors;
- developing and reviewing the Company's policies and practices on corporate governance and making recommendations to the Board and report to the Board on matters;
- reviewing the Company's compliance with the Hong Kong CG Code and disclosure in the Corporate Governance Report; and
- considering any other topics, as determined by the Board.

There were three meetings of the Audit and Compliance Committee held for the year ended December 31, 2015, the attendance record of the committee members is set out above. The following is a summary of the major work performed by the Audit and Compliance Committee during 2015:

- reviewed the reports and findings from management including internal audit on the implementation and refinement of the internal control measures;
- confirmed the independence and objectivity of the Company's external auditor, PricewaterhouseCoopers;
- met with the external auditor and reviewed their 2015 audit plan;
- reviewed the annual results and the adequacy of the internal control system for the year ended December 31, 2014; and
- reviewed the interim results for the six months ended June 30, 2015.

Subsequent to December 31, 2015 and up to the date of this Annual Report, a meeting of the Audit and Compliance Committee was held on March 15, 2016 to review the annual results and the adequacy of the internal control system for the year ended December 31, 2015.

**CORPORATE GOVERNANCE REPORT****THE REMUNERATION AND NOMINATION COMMITTEE**

The Board established a Remuneration and Nomination Committee on June 15, 2013 with written terms of reference in compliance with paragraphs B.1 and A.5 of the Hong Kong CG Code. These terms of reference include appropriate professional knowledge and industry experience, personal ethics, integrity and personal skill as well as time commitments of members. The Remuneration and Nomination Committee consists of three members, comprising TSANG, Hing Lun, LIU, Jianjun and WANG, Xiaobo. All members of the Remuneration and Nomination Committee are Non-executive Directors, among whom TSANG, Hing Lun and LIU, Jianjun are Independent Non-executive Directors. The chairman of the Remuneration and Nomination Committee is TSANG, Hing Lun. The primary functions of the Remuneration and Nomination Committee include, without limitation, (i) making recommendations to the Board on our policy and structure for all remuneration of Directors and senior management and on the establishment of a formal and transparent procedure for developing policy on such remuneration; (ii) making recommendations on the remuneration packages of executive and non-executive Directors and senior management; (iii) reviewing and approving senior management's remuneration proposals reference to corporate goals and objectives resolved by the Board from time to time; (iv) reviewing the structure, size, composition and diversity of the Board; (v) assessing the independence of Independent Non-executive Directors; and (vi) making recommendations to the Board on matters relating to the appointment of Directors.

The remuneration of Directors and senior executives is determined with reference to their expertise and experience in the industry, the performance and profitability of the Group as well as remuneration benchmarks from other local and international companies and prevailing market conditions. Directors and employees also participate in bonus arrangements which are determined in accordance with the performance of the Group and the individual's performance. No Director or any of his associates takes part in any discussion about his own remuneration.

There were two meetings of the Remuneration and Nomination Committee held for the year ended December 31, 2015, the attendance record of the committee members is set out above. The following is a summary of the major work performed by the Remuneration and Nomination Committee during 2015:

- reviewed and made a recommendation to the Board regarding the fees of the Non-executive Directors;
- reviewed and made a recommendation to the Board regarding the fees of the Independent Non-Executive Directors;
- reviewed the Board structure, size, composition and board diversity (including ability, knowledge and experience etc.);
- confirmed the independence of Independent Non-executive Directors; and
- considered the retirement and re-nomination of Directors for re-election at the forthcoming AGM.

## CORPORATE GOVERNANCE REPORT

### BOARD DIVERSITY POLICY

The Company views diversity at the Board level as an essential element in supporting the attainment of its strategic objectives and its sustainable development. To that end, the Company has adopted a board diversity policy to set out the approach to achieve diversity on the Board. In designing the Board's composition, Board diversity has been considered from a number of aspects, including but not limited to gender, age, cultural and educational background, ethnicity, professional experience, skills, knowledge and length of service. Ultimately, all Board appointments have been based on merit, and candidates were considered against objective criteria, having due regard for the benefits of diversity on the Board.

### AUDITOR'S REMUNERATION

The Company's external auditor is PricewaterhouseCoopers. The remuneration paid to PricewaterhouseCoopers in respect of the audit services and non-audit services for the year ended December 31, 2015 was approximately US\$2.2 million and US\$1.5 million, respectively. A breakdown analysis of the remuneration paid to PricewaterhouseCoopers for the year ended December 31, 2015 is set out below. The Audit and Compliance Committee has confirmed the independence and objectivity of the external auditor.

Service Category	Fees Paid US\$'000
Audit Services	2,160
Non-audit Services – Tax consulting and compliance	1,457
Total	3,617

Tax consulting and compliance services rendered include the preparation of required tax filings and correspondence with related authorities in certain jurisdictions and the delivery of advice on the application of relevant tax regulations to unusual or significant transactions, as such matters arise.

### JOINT COMPANY SECRETARIES

Ms. MOK, Ming Wai, a director of KCS Hong Kong Limited, an external service provider, has been engaged by the Company as its Joint Company Secretary and authorised representative. The primary contact person of the Company is Mr. FAN, Yi, the Joint Company Secretary, the authorised representative and an Executive Director of the Company.

During 2015, each of the Joint Company Secretaries undertook no less than 15 hours of professional training to update their respective skills and knowledge.

### SHAREHOLDERS' RIGHTS

To safeguard Shareholders' interests and rights, a separate resolution is proposed for each substantially separate issue at general meetings, including the election of individual Directors. Except where the chairman, in good faith, decides to allow a resolution which relates purely to a procedural or administrative matter to be voted on by a show of hands, all resolutions put forward at general meetings will be voted on by poll pursuant to the Listing Rules. Poll results will be posted on the websites of the Company and of the Hong Kong Stock Exchange after each general meeting. There are no provisions under the laws of the Cayman Islands or the Memorandum and Articles of Association that allows Shareholders to make proposals or move resolutions at an annual general meeting. Shareholders of the Company who wish to make proposals or move a resolution may, however, request the Board to convene an extraordinary general meeting by following the procedures below.



**CORPORATE GOVERNANCE REPORT****PROCEDURES FOR SHAREHOLDERS TO CONVENE AN EXTRAORDINARY GENERAL MEETING**

Extraordinary general meetings may be convened on the written request of any two or more Shareholders of the Company deposited at the principal place of business of the Company in Hong Kong or, in the event the Company ceases to have such a principal place of business, the registered office specifying the objects of the meeting and signed by the requestors, provided that such requestors held as at the date of deposit of the request not less than one-tenth of the paid up capital of the Company which carries the right of voting at general meetings of the Company.

Extraordinary general meetings may also be convened on the written request of any one Shareholder of the Company which is a recognised clearing house (or its nominee(s)) deposited at the principal place of business of the Company in Hong Kong or, in the event the Company ceases to have such a principal place of business, the registered office specifying the objects of the meeting and signed by the requester, provided that such requester held as at the date of deposit of the requisition not less than one-tenth of the paid up capital of the Company which carries the right of voting at general meetings of the Company.

If the Board does not within 21 days from the date of deposit of the request proceed duly to convene the extraordinary general meeting to be held within a further 21 days, the requestor(s) themselves, or any of them representing more than one-half of the total voting rights of all of them, may convene the extraordinary general meeting in the same manner, as nearly as possible, as that in which meetings may be convened by the Board provided that any meeting so convened shall not be held after the expiration of three months from the date of deposit of the request, and all reasonable expenses incurred by the requestor(s) as a result of the failure of the Board shall be reimbursed to them by the Company.

**SHAREHOLDERS' ENQUIRIES**

Enquiries about corporate governance or other related matters should be directed to the Joint Company Secretary by email at [company.secretary@nexteer.com](mailto:company.secretary@nexteer.com) or at the Company's headquarters address: 3900 East Holland Road, Saginaw, MI 48601-9494, United States.

Shareholders should direct their enquiries about their shareholdings to the Company's share registrar as follows:

By Mail:	17M Floor, Hopewell Centre 183 Queen's Road East Wanchai, Hong Kong
Hong Kong Customer Service Phone:	+852 2862 8555
Email:	<a href="mailto:hkinfo@computershare.com.hk">hkinfo@computershare.com.hk</a>

## CORPORATE GOVERNANCE REPORT

### REMUNERATION OF DIRECTORS AND SENIOR MANAGEMENT

The Group has established a formal and transparent procedure for formulating policies on remuneration of Directors and senior management of the Group. Details of the remuneration of each of the Directors for the year ended December 31, 2015 are set out in note 25 to the Consolidated Financial Statements. The remuneration of Directors is determined by the Board, which receives recommendations from the Remuneration and Nomination Committee after considering the experience, knowledge and performance of the Directors. Under the Company's current compensation arrangements, the Executive Directors and Senior Managers receive cash compensation in the form of salaries as well as bonuses that are subject to performance targets.

Remuneration paid to the Senior Managers (including three Executive Directors) for the year ended December 31, 2015 is within the following bands:

<b>Band of remuneration in US\$</b>	<b>No. of person</b>
US\$nil – US\$250,000	1
US\$500,001 – US\$750,000	5
US\$750,001 – US\$1,000,000	2
US\$1,000,001 – US\$1,250,000	1
US\$3,500,001 – US\$3,750,000	1

### DIRECTORS' RESPONSIBILITY FOR THE FINANCIAL STATEMENTS

The Company has implemented a series of reports intended to allow the Board to assess the Group's financial and operational performance, as well as business results. On a monthly basis, management of the Group provides the Board with sufficient and adequate information to support its decision-making and oversight responsibilities.

The Board understands and acknowledges its responsibility for overseeing the preparation of the financial information in accordance with IFRS and for the internal control system necessary to enable the preparation of financial information that is free from material misstatement. This responsibility extends to annual and interim reports, other announcements and other financial disclosures required under the Listing Rules and/or statutory requirements. As at the date of this Annual Report, the Board is not aware of any material uncertainties relating to events or conditions that may cast significant doubt upon the Company's or the Group's ability to continue as a going concern.

The Company's external auditor is responsible for expressing an opinion on whether the Consolidated Financial Statements give a true and fair view of the state of affairs of the Group as at December 31, 2015, and of the Group's profit and cash flows for the year then ended in accordance with IFRS.

The auditor's statement about their reporting responsibilities on the Consolidated Financial Statements is set out in the section headed 'Independent Auditor's Report' of this Annual Report.

## CORPORATE GOVERNANCE REPORT

### INTERNAL CONTROL

The responsibility for safeguarding the assets, for the prevention and detection of fraud and error, and for ensuring compliance with all applicable laws and regulations rests with the Board, the Audit and Compliance Committee and management of the Group. This responsibility includes implementing and ensuring the continued operation of internal control systems which are designed to prevent and detect fraud and error.

The Board is responsible for maintaining an adequate system of internal control and for reviewing its effectiveness. Oversight over internal controls is led by the Audit and Compliance Committee, established on June 15, 2013. While senior management is responsible for the implementation of such system of internal control and risk management, the Group continues to establish an Internal Audit department to assist the Board and the Audit and Compliance Committee in their oversight and review responsibilities to monitor the compliance and effectiveness of the internal control measures. This will enable the Board and the Audit and Compliance Committee to conduct necessary reviews and to report to Shareholders, at least on an annual basis, on the effectiveness of the Group's system of risk management and internal control.

Members of the Internal Audit department have direct access to the Board through reporting to the Chairman of the Audit and Compliance Committee, and report to the CFO. The Head of the Internal Audit department has the right to consult the Audit and Compliance Committee without reference to management. With this independence, the Internal Audit department is able to perform key tasks, such as: (a) assessing and monitoring compliance with policies and the effectiveness of internal control measures with unrestricted direct access to any level of management whenever deemed necessary; and (b) conducting comprehensive internal audits to evaluate the system of financial, operation and compliance controls on a regular basis.

The Internal Audit department has completed a risk assessment process and developed a three year internal audit plan that focuses on the key financial statement risks to the Company. The Company reviewed the risk assessment and three-year internal audit plans with the Audit and Compliance Committee in 2015. The Internal Audit department executed the approved internal audit plan and conducted a review of the effectiveness of the system of internal controls including but not limited to the audit of the internal controls over financial reporting for key high risk frameworks of the Company. The Internal Audit department reported summary audit findings and recommendations to the Audit and Compliance Committee. Management is responsible for ensuring that control weaknesses highlighted in internal audits are rectified within a reasonable period.

Management and the CFO, in conjunction with the Board and the Audit and Compliance Committee, continue to evaluate the adequacy of resources, qualifications and experience of staff in the Group's accounting and financial reporting function, as well as that function's training programs and budget. This exercise continues to result in the hiring of accounting and finance professionals to help ensure that the Group maintains adequate and sufficient staffing levels required for a public company. The Board has delegated to the Audit and Compliance Committee the responsibility for reviewing the Group's internal controls and reporting the findings to the Board. The Audit and Compliance Committee conducted a review of (1) the findings and recommendations of the internal audit function; (2) the implementation status of recommended internal control recommendations; and (3) the reports and findings from management on the implementation of the internal control measures. Based on its review, the Board and the Audit and Compliance Committee are not aware of any material deficiencies in the effectiveness of internal controls for the year ended December 31, 2015.

### CHANGE IN CONSTITUTIONAL DOCUMENTS

There was no change in the Memorandum and Articles of Association of the Company for the year ended December 31, 2015.

# INDEPENDENT AUDITOR'S REPORT



羅兵咸永道

**INDEPENDENT AUDITOR'S REPORT  
TO THE SHAREHOLDERS OF NEXTEER AUTOMOTIVE GROUP LIMITED**  
*(incorporated in the Cayman Islands with limited liability)*

We have audited the consolidated financial statements of Nexteer Automotive Group Limited (the 'Company') and its subsidiaries set out on pages 66 to 135, which comprise the consolidated balance sheet as at December 31, 2015, and the consolidated income statement, the consolidated statement of comprehensive income, the consolidated statement of changes in equity and the consolidated statement of cash flows for the year then ended, and a summary of significant accounting policies and other explanatory information.

## **DIRECTORS' RESPONSIBILITY FOR THE CONSOLIDATED FINANCIAL STATEMENTS**

The directors of the Company are responsible for the preparation of consolidated financial statements that give a true and fair view in accordance with International Financial Reporting Standards and the disclosure requirements of the Hong Kong Companies Ordinance, and for such internal control as the directors determine is necessary to enable the preparation of consolidated financial statements that are free from material misstatement, whether due to fraud or error.

## **AUDITOR'S RESPONSIBILITY**

Our responsibility is to express an opinion on these consolidated financial statements based on our audit. We conducted our audit in accordance with International Standards on Auditing. Those standards require that we comply with ethical requirements and plan and perform the audit to obtain reasonable assurance about whether the consolidated financial statements are free from material misstatement.

An audit involves performing procedures to obtain audit evidence about the amounts and disclosures in the consolidated financial statements. The procedures selected depend on the auditor's judgement, including the assessment of the risks of material misstatement of the consolidated financial statements, whether due to fraud or error. In making those risk assessments, the auditor considers internal control relevant to the entity's preparation of consolidated financial statements that give a true and fair view in order to design audit procedures that are appropriate in the circumstances, but not for the purpose of expressing an opinion on the effectiveness of the entity's internal control. An audit also includes evaluating the appropriateness of accounting policies used and the reasonableness of accounting estimates made by the directors, as well as evaluating the overall presentation of the consolidated financial statements.

We believe that the audit evidence we have obtained is sufficient and appropriate to provide a basis for our audit opinion.

## INDEPENDENT AUDITOR'S REPORT



羅兵咸永道

**OPINION**

In our opinion, the consolidated financial statements give a true and fair view of the financial position of the Company and its subsidiaries as at December 31, 2015, and of their financial performance and cash flows for the year then ended in accordance with International Financial Reporting Standards and have been properly prepared in compliance with the disclosure requirements of the Hong Kong Companies Ordinance.

**OTHER MATTERS**

This report, including the opinion, has been prepared for and only for you, as a body, and for no other purpose. We do not assume responsibility towards or accept liability to any other person for the contents of this report.

**PricewaterhouseCoopers***Certified Public Accountants*

Hong Kong, March 15, 2016



# CONSOLIDATED BALANCE SHEET

As at December 31, 2015

	Notes	As at December 31,	
		2015 US\$'000	2014 US\$'000
<b>ASSETS</b>			
<b>Non-current assets</b>			
Property, plant and equipment	6	685,275	625,924
Land use rights	7	634	689
Intangible assets	8	407,671	343,827
Deferred income tax assets	9	11,083	9,967
Other receivables and prepayments	13	6,107	10,410
Investment in a joint venture	32(b)	9,902	5,645
		<b>1,120,672</b>	<b>996,462</b>
<b>Current assets</b>			
Inventories	11	253,942	226,049
Trade receivables	12	569,978	525,225
Other receivables and prepayments	13	94,523	93,291
Derivative financial instruments	10	659	–
Restricted bank deposits	14	148	772
Cash and cash equivalents	15	416,900	380,173
		<b>1,336,150</b>	<b>1,225,510</b>
<b>Total assets</b>		<b>2,456,822</b>	<b>2,221,972</b>

The notes on pages 72 to 135 are an integral part of these consolidated financial statements.

## CONSOLIDATED BALANCE SHEET (Continued)

	Notes	As at December 31, 2015 US\$'000	2014 US\$'000
<b>EQUITY</b>			
<b>Capital and reserves attributable to equity holders of the Company</b>			
Share capital	34	32,231	32,222
Other reserves	16	255,575	318,114
Retained earnings		539,616	333,283
		827,422	683,619
<b>Non-controlling interests</b>		26,943	24,400
<b>Total equity</b>		854,365	708,019
<b>LIABILITIES</b>			
<b>Non-current liabilities</b>			
Borrowings	17	560,539	634,012
Retirement benefits and compensations	18	17,544	29,960
Deferred income tax liabilities	9	51,503	22,755
Derivative financial instruments	10	–	543
Provisions	19	65,955	54,458
Deferred revenue	20	92,416	82,452
Other payables and accruals	22	7,174	7,908
		795,131	832,088
<b>Current liabilities</b>			
Trade payables	21	558,769	438,975
Other payables and accruals	22	97,562	77,341
Current income tax liabilities		12,503	14,072
Retirement benefits and compensations	18	2,949	2,757
Derivative financial instruments	10	5,878	3,484
Provisions	19	23,771	26,013
Deferred revenue	20	24,710	22,253
Borrowings	17	81,184	96,970
		807,326	681,865
<b>Total liabilities</b>		1,602,457	1,513,953
<b>Total equity and liabilities</b>		2,456,822	2,221,972

The notes on pages 72 to 135 are an integral part of these consolidated financial statements.

The financial statements on page 66 to 135 were approved by the Board of Directors on March 15, 2016 and were signed on its behalf.

\_\_\_\_\_  
Director

\_\_\_\_\_  
Director

# CONSOLIDATED INCOME STATEMENT

For the year ended December 31, 2015

	Notes	For the year ended December 31,	
		2015 US\$'000	2014 US\$'000
<b>Revenue</b>	5	3,360,512	2,978,068
Cost of sales	24	(2,815,609)	(2,558,070)
<b>Gross profit</b>		544,903	419,998
Engineering and product development costs	24	(96,919)	(80,070)
Selling and distribution expenses	24	(11,908)	(8,280)
Administrative expenses	24	(105,497)	(89,165)
Other losses, net	23	(17,449)	(5,587)
<b>Operating profit</b>		313,130	236,896
Finance income	26	2,253	1,912
Finance costs	26	(33,204)	(23,495)
Finance costs, net		(30,951)	(21,583)
Share of income/(loss) of a joint venture	32(b)	1,185	(717)
<b>Profit before income tax</b>		283,364	214,596
Income tax expense	27	(73,216)	(51,339)
<b>Profit for the year</b>		210,148	163,257
<b>Attributable to:</b>			
Equity holders of the Company		205,432	161,398
Non-controlling interests		4,716	1,859
		210,148	163,257
<b>Earnings per share for profit attributable to equity holders of the Company for the year (expressed in US\$ per share)</b>			
– Basic and diluted	28	\$0.08	\$0.06

The notes on pages 72 to 135 are an integral part of these consolidated financial statements.

# CONSOLIDATED STATEMENT OF COMPREHENSIVE INCOME

For the year ended December 31, 2015

	For the year ended December 31,	
	2015 US\$'000	2014 US\$'000
<b>Profit for the year</b>	210,148	163,257
<b>Other comprehensive income/(loss)</b>		
<b>Items that will not be reclassified to profit or loss</b>		
Actuarial gains/(losses) on defined benefit plans, net of tax of US\$(342,000) (2014: US\$794,000)	901	(1,797)
<b>Items that may be reclassified subsequently to profit or loss</b>		
Exchange differences, net of tax	(33,434)	(23,717)
Cash flow hedge	(834)	(56)
	(33,367)	(25,570)
<b>Total comprehensive income for the year</b>	176,781	137,687
<b>Attributable to:</b>		
Equity holders of the Company	173,207	136,330
Non-controlling interests	3,574	1,357
	176,781	137,687

The notes on pages 72 to 135 are an integral part of these consolidated financial statements.

# CONSOLIDATED STATEMENT OF CHANGES IN EQUITY

For the year ended December 31, 2015

	Attributable to equity holders of the Company							Non-controlling interests US\$'000	Total US\$'000	
	Share capital US\$'000	Share premium US\$'000 (note 16)	Merger reserve US\$'000 (note 16)	Share-based compensation reserve US\$'000	Exchange reserve US\$'000 (Note 16)	Hedging reserve US\$'000 (Note 16)	Retained earnings US\$'000			Sub-total US\$'000
<b>As at January 1, 2014</b>	32,222	252,643	113,000	-	(3,844)	-	173,682	567,703	23,043	590,746
<b>Comprehensive income</b>										
Profit for the year	-	-	-	-	-	-	161,398	161,398	1,859	163,257
<b>Other comprehensive loss</b>										
Exchange differences	-	-	-	-	(23,215)	-	-	(23,215)	(502)	(23,717)
Actuarial losses on defined benefit plans, net of tax	-	-	-	-	-	-	(1,797)	(1,797)	-	(1,797)
Cash flow hedge	-	-	-	-	-	(56)	-	(56)	-	(56)
<b>Total other comprehensive loss</b>	-	-	-	-	(23,215)	(56)	(1,797)	(25,068)	(502)	(25,570)
<b>Total comprehensive (loss)/income</b>	-	-	-	-	(23,215)	(56)	159,601	136,330	1,357	137,687
<b>Transactions with owners</b>										
Value of employee services provided under share option scheme (note 25(a))	-	-	-	1,240	-	-	-	1,240	-	1,240
Dividends paid to shareholders	-	(21,654)	-	-	-	-	-	(21,654)	-	(21,654)
<b>Total transactions with owners</b>	-	(21,654)	-	1,240	-	-	-	(20,414)	-	(20,414)
<b>As at December 31, 2014</b>	32,222	230,989	113,000	1,240	(27,059)	(56)	333,283	683,619	24,400	708,019
<b>Comprehensive income</b>										
Profit for the year	-	-	-	-	-	-	205,432	205,432	4,716	210,148
<b>Other comprehensive loss</b>										
Exchange differences	-	-	-	-	(32,292)	-	-	(32,292)	(1,142)	(33,434)
Actuarial gains on defined benefit plans, net of tax	-	-	-	-	-	-	901	901	-	901
Cash flow hedge	-	-	-	-	-	(834)	-	(834)	-	(834)
<b>Total other comprehensive (loss)/income</b>	-	-	-	-	(32,292)	(834)	901	(32,225)	(1,142)	(33,367)
<b>Total comprehensive (loss)/income</b>	-	-	-	-	(32,292)	(834)	206,333	173,207	3,574	176,781
<b>Transactions with owners</b>										
Dividends to non-controlling shareholders of subsidiaries	-	-	-	-	-	-	-	-	(1,031)	(1,031)
Value of employee services provided under share option scheme (note 25(a))	-	-	-	2,725	-	-	-	2,725	-	2,725
Proceeds from exercise of options	9	257	-	-	-	-	-	266	-	266
Dividends paid to shareholders	-	(32,395)	-	-	-	-	-	(32,395)	-	(32,395)
<b>Total transactions with owners</b>	9	(32,138)	-	2,725	-	-	-	(29,404)	(1,031)	(30,435)
<b>As at December 31, 2015</b>	32,231	198,851	113,000	3,965	(59,351)	(890)	539,616	827,422	26,943	854,365

The notes on pages 72 to 135 are an integral part of these consolidated financial statements.



# CONSOLIDATED STATEMENT OF CASH FLOWS

For the year ended December 31, 2015

	Notes	For the year ended December 31,	
		2015 US\$'000	2014 US\$'000
<b>Operating activities</b>			
Cash generated from operations	30(a)	517,020	305,099
Income tax paid		(48,754)	(51,033)
Net cash generated from operating activities		468,266	254,066
<b>Investing activities</b>			
Purchase of property, plant and equipment		(165,609)	(172,482)
Addition of intangible assets		(111,867)	(106,602)
Proceeds from sale of property, plant and equipment		3,536	6,759
Changes in restricted bank deposits		623	2,983
Investment in a joint venture		(3,072)	(6,362)
Net cash used in investing activities		(276,389)	(275,704)
<b>Financing activities</b>			
Proceeds from issuance of notes	17(1)(e)	–	250,000
Proceeds from borrowings		56,222	90,528
Repayments of borrowings		(147,612)	(197,561)
Finance costs paid		(36,960)	(26,337)
Payments of notes issuance expenses		–	(4,467)
Dividends paid to non-controlling interests		(1,031)	–
Dividends paid to equity holders of the Company		(32,395)	(21,654)
Proceeds from exercise of options		266	–
Net cash (used in)/generated from financing activities		(161,510)	90,509
<b>Net increase in cash and cash equivalents</b>		<b>30,367</b>	<b>68,871</b>
Cash and cash equivalents at beginning of period		380,173	314,120
Effect of exchange rate changes on cash and cash equivalents		6,360	(2,818)
<b>Cash and cash equivalents at end of period</b>		<b>416,900</b>	<b>380,173</b>

The notes on pages 72 to 135 are an integral part of these consolidated financial statements.

# NOTES TO THE CONSOLIDATED FINANCIAL STATEMENTS

For the year ended December 31, 2015

## 1 GENERAL INFORMATION

Nexteer Automotive Group Limited (the 'Company') was incorporated in the Cayman Islands on August 21, 2012 as an exempted company with limited liability under Companies Law, Cap. 22 (Law 3 of 1961, as consolidated and revised) of the Cayman Islands. The address of the Company's registered office is PO Box 309, Ugland House, Grand Cayman, KY1-1104, Cayman Islands.

The Company is an investment holding company. The Company, together with its subsidiaries (collectively referred to as the 'Group'), are principally engaged in the design and manufacture of steering and driveline systems and components for automobile manufacturers and other automotive-related companies. The Group's primary operations are in the United States of America ('USA' or 'US'), Mexico, Poland and the People's Republic of China ('China') and are structured to supply its customers globally. The principal markets for the Group's products are North America, Europe and China.

The Company's directors regard Aviation Industry Corporation of China ('AVIC'), a company established in China, as being the ultimate holding company of the Company.

The Company's shares have been listed on the Main Board of The Stock Exchange of Hong Kong Limited since October 7, 2013 (the 'Listing').

These financial statements are presented in US dollars, unless otherwise stated. These financial statements have been approved for issue by the Board of Directors on March 15, 2016.

## 2 SUMMARY OF SIGNIFICANT ACCOUNTING POLICIES

The principal accounting policies applied in the preparation of these consolidated financial statements are set out below. These policies have been consistently applied to all the years presented, unless otherwise stated.

### 2.1 Basis of preparation

The consolidated financial statements of the Company have been prepared in accordance with all applicable International Financial Reporting Standards ('IFRS') issued by the International Accounting Standards Board ('IASB'). The financial statements have been prepared under the historical cost convention, as modified by the revaluation of derivative financial instruments at fair value through profit or loss.

The preparation of financial statements in conformity with IFRS requires the use of certain critical accounting estimates. It also requires management to exercise its judgement in the process of applying the Group's accounting policies. The areas involving a higher degree of judgement or complexity, or areas where assumptions and estimates are significant to the consolidated financial statements are disclosed in note 4.

## NOTES TO THE CONSOLIDATED FINANCIAL STATEMENTS

### 2 SUMMARY OF SIGNIFICANT ACCOUNTING POLICIES (Continued)

The principal accounting policies applied in the preparation of these consolidated financial statements are set out below. These policies have been consistently applied to all the years presented, unless otherwise stated.

#### 2.2 Subsidiaries

##### (a) Consolidation

Subsidiaries are all entities over which the Group has control. The Group controls an entity where the Group is exposed to, or has rights to, variable returns from its involvement with the entity and has the ability to affect those returns through its power to direct the activities of the entity. Subsidiaries are fully consolidated from the date on which control is transferred to the Group. They are deconsolidated from the date that control ceases, intercompany transactions, balances, income and expenses on transactions between group companies are eliminated. Profits and losses resulting from inter-company transactions that are recognised in assets are also eliminated.

The Group applies the acquisition method to account for business combinations except for business combination under common control which are accounted for using the principles of merger accounting. Under the acquisition method, the consideration transferred for the acquisition is the fair values of the assets transferred, the liabilities incurred and the equity interests issued by the Group. The consideration transferred includes the fair value of any asset or liability resulting from a contingent consideration arrangement. Identifiable assets acquired and liabilities and contingent liabilities assumed in a business combination are measured initially at their fair values at the acquisition date. The Group recognises any non-controlling interest on an acquisition-by-acquisition basis, either at fair value or at the non-controlling interest's proportionate share of the recognised amounts of acquiree's identifiable net assets.

Acquisition-related costs are expensed as incurred.

##### (b) Separate financial statements

Investments in subsidiaries are accounted for at cost less impairment. Cost also includes direct attributable costs of investment. The results of subsidiaries are accounted for by the Company on the basis of dividend received and receivable.

Impairment testing of the investments in subsidiaries is required upon receiving dividends from these investments if the dividend exceeds the total comprehensive income of the subsidiary in the period the dividend is declared or if the carrying amount of the investment in the separate financial statements exceeds the carrying amount in the consolidated financial statements of the subsidiaries' net assets including goodwill.

#### 2.3 Joint arrangements

Joint arrangements are classified as either joint operations or joint ventures, depending on the contractual rights and obligations of each investor. The Group has assessed the nature of its joint arrangements and determined them to be joint ventures. Non-consolidated joint ventures are accounted for using the equity method of accounting.

Under the equity method of accounting, interests in joint ventures are initially recognised at cost and adjusted thereafter to recognise the Group's share of the post-acquisitions profits or losses and movements in other comprehensive income. When the Group's share of losses in a joint venture equals or exceeds its interests in the joint ventures, the Group does not recognise further losses, unless it has incurred obligations or made payments on behalf of the joint ventures. Any distributions the Group receives from the joint ventures reduce the carrying amount of the investment.

## NOTES TO THE CONSOLIDATED FINANCIAL STATEMENTS

### 2 SUMMARY OF SIGNIFICANT ACCOUNTING POLICIES (Continued)

#### 2.3 Joint arrangements (Continued)

Unrealised gains on transactions between the Group and its joint ventures are eliminated to the extent of the Group's interests in the joint ventures. Unrealised losses are also eliminated unless the transaction provides evidence of an impairment of the asset transferred. Accounting policies of the joint ventures have been aligned where necessary to ensure consistency with the policies adopted by the Group.

#### 2.4 Segment reporting

Operating segments are reported in a manner consistent with the internal reporting to the chief operating decision maker who has been identified as the Chief Executive Officer ('CEO'). The CEO is responsible for resource allocation and assessing the performance of the operating segments.

#### 2.5 Foreign currency translation

##### (a) *Functional and presentation currency*

Items included in the financial statements of each of the Group's entities are measured using functional currency in accordance with IAS 21. The consolidated financial statements are presented in US dollars, which is the Company's functional currency and the Group's presentation currency.

##### (b) *Transactions and balances*

Foreign currency transactions are translated into the functional currency using the exchange rates prevailing at the dates of the transactions or valuation where items are re-measured, except when deferred in other comprehensive income as qualifying cash flow hedge. Foreign exchange gains and losses resulting from the settlement of such transactions and from the translation at year-end exchange rates of monetary assets and liabilities denominated in foreign currencies are recognised in the income statement, except for those intercompany balances which are designated as being of a long-term investment nature.

##### (c) *Group companies*

The results of operations and financial position of all the group entities (none of which has the currency of a hyper-inflationary economy) that have a functional currency different from the presentation currency are translated into the presentation currency as follows:

- (i) Assets and liabilities for each balance sheet presented are translated at the closing rate at the date of that balance sheet;
- (ii) Income and expenses for each income statement are translated at average exchange rates (unless this average is not a reasonable approximation of the cumulative effect of the rates prevailing on the transaction dates, in which case income and expenses are translated at the rate on the dates of the related transactions); and
- (iii) All resulting exchange differences are recognised in other comprehensive income.

## NOTES TO THE CONSOLIDATED FINANCIAL STATEMENTS

### 2 SUMMARY OF SIGNIFICANT ACCOUNTING POLICIES (Continued)

#### 2.6 Property, plant and equipment

Items of property, plant and equipment (including tools but excluding construction-in-progress) are measured at cost less accumulated depreciation and accumulated impairment losses. Improvements that materially extend the useful life of these assets are capitalised. When parts of an item of property, plant and equipment have different useful lives, they are accounted for as separate items (major components) of property, plant and equipment.

Subsequent costs are included in the asset's carrying amount or as a separate asset, as appropriate, only when it is probable that future economic benefits associated with the item will flow to the Group and the cost of the item can be measured reliably. The carrying amount of the replaced part is derecognised. All other repairs and maintenance are charged to the income statement during the financial period in which they are incurred.

Freehold land is not depreciated. Depreciation on items of property, plant and equipment is calculated using the straight-line method to allocate their cost to their residual values over their estimated useful lives as follows:

Leasehold improvements	6 – 18 years or over lease term, whichever is shorter
Buildings	20 – 40 years
Machinery, equipment and tooling	3 – 20 years
Furniture and office equipment	3 – 18 years

Tooling represents tools, dies, jigs and other items used in the manufacturing of customer specific parts. Tools owned by the Group are capitalised as property, plant and equipment and depreciated to cost of sales over their useful lives.

The assets' residual values and useful lives are reviewed annually, and adjusted if appropriate.

An asset's carrying amount is written down immediately to its recoverable amount if the asset's carrying amount is greater than its estimated recoverable amount (note 2.9).

Gains and losses on disposal are determined by comparing the proceeds with the carrying amount and are recognised within 'Other losses, net' in the income statement.

Construction-in-progress represents leasehold improvements, buildings, machinery and equipment under construction or pending installation and is stated at cost less accumulated impairment losses. Cost includes the costs of construction, installation, testing and other direct costs, and capitalised interest. No provision for depreciation is made on construction-in-progress until such time as the relevant assets are completed and ready for intended use.



## NOTES TO THE CONSOLIDATED FINANCIAL STATEMENTS

### 2 SUMMARY OF SIGNIFICANT ACCOUNTING POLICIES (Continued)

#### 2.7 Land use rights

Land use rights represent prepayment for operating leases and are stated at cost less accumulated amortisation and accumulated impairment losses. Cost represents consideration paid for the rights to use the land on which various plants and buildings are situated. Amortisation of land use rights is calculated on a straight-line basis over the period of the land use rights.

#### 2.8 Intangible assets

##### (a) *Research and development*

The Group incurs significant costs and efforts on research and development activities, which include expenditures on customer-specific applications, prototypes and testing. Research expenditures are charged to the income statement as an expense in the period the expenditure is incurred. Development costs are recognised as assets if they can be clearly assigned to a newly developed product or process and all the following can be demonstrated:

- (i) The technical feasibility to complete the development project so that it will be available for use or sale;
- (ii) The intention to complete the development project to use it;
- (iii) The ability to use the output of the development project;
- (iv) The manner in which the development project will generate probable future economic benefits for the Group;
- (v) The availability of adequate technical, financial and other resources to complete the development project and use or sell the intangible asset; and
- (vi) The expenditure attributable to the asset during its development can be reliably measured.

The cost of an internally generated intangible asset is the sum of the expenditure incurred from the date the asset meets the recognition criteria above to the date when it is available for use. The costs capitalised in connection with the intangible asset include costs of materials and services used or consumed and employee costs incurred in the creation of the asset.

Capitalised development costs are amortised using the straight-line method over the life of the related program, usually four to seven years.

Development expenditures not satisfying the above criteria are recognised in the income statement as incurred. Development costs previously recognised as an expense are not recognised as an asset in the subsequent period.

## NOTES TO THE CONSOLIDATED FINANCIAL STATEMENTS

### 2 SUMMARY OF SIGNIFICANT ACCOUNTING POLICIES (Continued)

#### 2.8 Intangible assets (Continued)

##### (b) Computer software

Cost associated with maintaining computer software programs are recognised as an expense as incurred. Development costs that are directly attributable to the design and testing of identifiable and unique software products controlled by the Group are recognised as intangible assets when the following criteria are met:

- (i) It is technically feasible to complete the software product and use it;
- (ii) Management intends to complete the software product and use it;
- (iii) There is an ability to use the software product;
- (iv) It can be demonstrated how the software product will generate probable future economic benefits;
- (v) Adequate technical, financial and other resources to complete the development and to use the software product is available; and
- (vi) The expenditure attributable to the software product during its development can be reliably measured.

Directly attributable costs that are capitalised as part of the software product include the software development employee costs and an appropriate portion of relevant overheads.

Other development expenditures that do not meet these criteria are recognised as an expense as incurred. Development costs previously recognised as an expense are not recognised as an asset in the subsequent period.

Computer software development costs recognised as assets are amortised over their estimated useful lives, which does not exceed five years.

#### 2.9 Impairment of non-financial assets

Assets that have an indefinite useful life and intangible development assets not ready to use are not subject to amortisation and are tested annually for impairment and whenever there is an indication of impairment. Assets that are subject to amortisation are reviewed for impairment whenever events or changes in circumstances indicate that the carrying amount may not be recoverable. An impairment loss is recognised for the amount by which the asset's carrying amount exceeds its recoverable amount. The recoverable amount is the higher of an asset's fair value less costs to sell and value in use. For the purposes of assessing impairment, assets are grouped at the lowest levels for which there are separately identifiable cash flows ('cash-generating units'). Non-financial assets other than goodwill that suffered an impairment are reviewed for possible reversal of the impairment at each reporting date.

## NOTES TO THE CONSOLIDATED FINANCIAL STATEMENTS

### 2 SUMMARY OF SIGNIFICANT ACCOUNTING POLICIES (Continued)

#### 2.10 Financial assets

##### (a) Classification

The Group classifies its financial assets into the following categories: at fair value through profit or loss, loans and receivables, held-to-maturity and available-for-sale. The classification depends on the purposes for which the financial assets were acquired. Management determines the classification of its financial assets at initial recognition.

The Group's financial assets primarily comprise loans and receivables and financial assets at fair value.

Loans and receivables are non-derivative financial assets with fixed or determinable payments that are not quoted in an active market. They are included in current assets, except for the amounts that are expected to be settled more than 12 months after the end of the reporting period. These are classified as non-current assets. The Group's loans and receivables comprise 'trade and other receivables' (note 2.13) and 'cash and cash equivalents' (note 2.14) in the balance sheet.

Financial assets carried at fair value through profit or loss are financial assets held for trading. A financial asset is classified in this category if acquired principally for the purpose of selling in the short term. Derivatives are also categorised as held for trading unless they are designated as hedges. Assets in this category are classified as current assets if expected to be settled within 12 months; otherwise, they are classified as non-current.

##### (b) Recognition and measurement

Regular way purchases and sales of financial assets are recognised on the trade-date – the date on which the Group commits to purchase or sell the asset. Investments are initially recognised at fair value plus transaction costs for all financial assets not carried at fair value through profit or loss. Financial assets carried at fair value through profit or loss are initially recognised at fair value, and transaction costs are expensed in the income statement. Financial assets are derecognised when the rights to receive cash flows from the investments have expired or have been transferred and the Group has transferred substantially all risks and rewards of ownership. Available-for-sale financial assets and financial assets at fair value through profit or loss are subsequently carried at fair value. Loans and receivables are subsequently carried at amortised cost using the effective interest method.

##### (c) Offsetting financial instruments

Financial assets and liabilities are offset and the net amount reported in the balance sheet when there is a legally enforceable right to offset the recognised amounts and there is an intention to settle on a net basis or realise the asset and settle the liability simultaneously. The legally enforceable right must not be contingent on future events and must be enforceable in the normal course of business and in the event of default, insolvency or bankruptcy of the company or the counterparty.

## NOTES TO THE CONSOLIDATED FINANCIAL STATEMENTS

### 2 SUMMARY OF SIGNIFICANT ACCOUNTING POLICIES (Continued)

#### 2.10 Financial assets (Continued)

##### (d) Impairment of financial assets

The Group assesses at the end of each reporting period whether there is objective evidence that a financial asset or group of financial assets is impaired. A financial asset or a group of financial assets is impaired and impairment losses are incurred only if there is objective evidence of impairment as a result of one or more events that occurred after the initial recognition of the asset (a 'loss event') and that loss event (or events) has an impact on the estimated future cash flows of the financial asset or group of financial assets that can be reliably estimated.

Evidence of impairment may include indications that the debtors or a group of debtors is experiencing significant financial difficulty, default or delinquency in interest or principal payments, the probability that they will enter bankruptcy or other financial reorganisation, and where observable data indicate that there is a measurable decrease in the estimated future cash flows, such as changes in arrears or economic conditions that correlate with defaults.

For loans and receivables, the amount of the loss is measured as the difference between the asset's carrying amount and the present value of estimated future cash flows (excluding future credit losses that have not been incurred) discounted at the financial asset's original effective interest rate. The carrying amount of the asset is reduced and the amount of the loss is recognised in the income statement. If a loan has a variable interest rate, the discount rate for measuring any impairment loss is the current effective interest rate determined under the contract. As a practical expedient, the Group may measure impairment on the basis of an instrument's fair value using an observable market price.

If, in a subsequent period, the amount of the impairment loss decreases and the decrease can be related objectively to an event occurring after the impairment was recognised (such as an improvement in the debtor's credit rating), the reversal of the previously recognised impairment loss is recognised in the income statement.

#### 2.11 Derivative financial instruments and hedging activities

Derivatives are initially recognised at fair value on the date a derivative contract is entered into and are subsequently re-measured at their fair value. The method of recognising the resulting gain or loss depends on whether the derivative is designated as a hedging instrument, and if so, the nature of the item being hedged. All of the Group's hedging instruments are designated as hedges of a particular risk associated with a recognised asset or liability or a highly probable forecast transaction (cash flow hedge).

The Group documents at the inception of the transaction the relationship between hedging instruments and hedged items, as well as its risk management objectives and strategy for undertaking various hedging transactions. The Group also documents its assessment, both at hedge inception and on an ongoing basis, of whether the derivatives that are used in hedging transactions are highly effective in offsetting changes in cash flows of hedged items.

The fair values of various derivative instruments used for hedging purposes are disclosed in note 10. Movements on the hedging reserve in shareholder's equity are shown in the consolidated statement of changes in equity. The full fair value of hedging derivatives are classified as current assets or liabilities if expected to be settled within twelve months, otherwise, they are classified as noncurrent.

## NOTES TO THE CONSOLIDATED FINANCIAL STATEMENTS

### 2 SUMMARY OF SIGNIFICANT ACCOUNTING POLICIES (Continued)

#### 2.11 Derivative financial instruments and hedging activities (Continued)

##### *Cash flow hedge*

The effective portion of changes in the fair value of derivatives that are designated and qualified as cash flow hedges are recognised in other comprehensive income. The gain or loss relating to the ineffective portion is recognised immediately in the income statement within 'other losses, net'.

Amounts accumulated in equity are reclassified to profit or loss in the period when the hedged item affects profit or loss. The gain or loss relating to the effective portion of interest rate swaps hedging variable rate borrowings is recognised in the income statement within 'finance costs'. Gains or losses related to forward exchange contracts used to hedge currency exposure are recognised in the income statement within 'cost of sales'.

When a hedging instrument expires or is sold, or when a hedge no longer meets the criteria for hedge accounting, any cumulative gain or loss existing in equity at that time remains in equity and is recognised when the forecast transaction is ultimately recognised in the income statement. When a forecast transaction is no longer expected to occur, the cumulative gain or loss that was reported in equity is immediately transferred to the income statement within 'other losses, net'.

#### 2.12 Inventories

Inventories are stated at the lower of cost and net realisable value. Cost is determined using the first-in, first-out ('FIFO') method. Inventory cost includes direct material, direct labor and related manufacturing overhead costs (based on normal operating capacity). Net realisable value is the estimated selling price in the ordinary course of business, less applicable selling expenses.

#### 2.13 Trade and other receivables

Trade receivables are amounts due from customers for merchandise sold or services performed in the ordinary course of business. If collection of trade and other receivables is expected in one year or less (or in the normal operating cycle of the business if longer), they are classified as current assets. If not, they are presented as non-current assets.

Trade receivables and other receivables are recognised initially at fair value and subsequently measured at amortised cost using the effective interest method, less provision for impairment.

#### 2.14 Cash and cash equivalents

Cash and cash equivalents includes cash in hand, deposits held at call with banks, other short-term highly liquid investments with original maturities of three months or less.

#### 2.15 Share capital

Ordinary shares are classified as equity. Incremental costs directly attributable to the issue of new shares are shown in equity as a deduction from the proceeds.

#### 2.16 Borrowings

Borrowings are recognised initially at fair value, net of transaction costs incurred. Borrowings are subsequently carried at amortised cost; any difference between the proceeds (net of transaction costs) and the redemption value is recognised in the income statement as finance cost over the period of the borrowings using the effective interest method.

Borrowings are classified as current liabilities unless the Group has an unconditional right to defer settlement of the liability for at least 12 months after the end of the reporting period.

## NOTES TO THE CONSOLIDATED FINANCIAL STATEMENTS

**2 SUMMARY OF SIGNIFICANT ACCOUNTING POLICIES** (Continued)**2.17 Borrowing costs**

General and specific borrowing costs directly attributable to the acquisition, construction or production of qualifying assets, which are assets that necessarily take a substantial period of time to get ready for their intended use or sale, are added to the cost of those assets, until such time as the assets are substantially ready for their intended use or sale.

The capitalisation rate is the weighted average of the borrowing costs applicable to the borrowings outstanding during the period up to the amount of actual borrowing costs incurred during that period. All other borrowing costs are recognised in profit or loss in the period in which they are incurred.

**2.18 Retirement obligations**

The Group has both defined contribution and defined benefit plans. Group companies operate various pension schemes. The schemes are generally funded through payments to insurance companies or trustee-administered funds, determined by periodic actuarial calculations.

*(a) Defined contribution plans*

A defined contribution plan is a pension plan under which the Group pays contributions into a separate entity. The Group has no legal or constructive obligations to pay further contributions if the fund does not hold sufficient assets to pay all employees the benefits relating to prior or current employee services.

The Group pays contributions to publicly or privately administered pension insurance plans on a mandatory or voluntary basis. The Group has no further payment obligations once the contributions have been paid. The contributions are recognised as employee benefit expense when they are due. Prepaid contributions are recognised as an asset to the extent that a cash refund or a reduction in the future payments is available.

*(b) Defined benefit plans*

A defined benefit plan is a pension plan that is not a defined contribution plan. Typically defined benefit plans define an amount of pension benefit that an employee will receive on retirement, usually dependent on one or more factors such as age, years of service and compensation.

The liability recognised in the balance sheet in respect of defined benefit pension plans is the present value of the defined benefit obligation at the end of the reporting period less the fair value of plan assets. The defined benefit obligation is calculated annually by independent actuaries using the projected unit credit method. The salary level trend refers to the expected rate of salary increase which is estimated annually depending on inflation and the career development of employees within the Group. The present value of the defined benefit obligation is determined by discounting the estimated future cash outflows using interest rates of high-quality corporate bonds that are denominated in the currency in which the benefits will be paid, and that have terms to maturity approximating to the terms of the related pension obligation. A company specific default risk is not taken into account.

Actuarial gains and losses arising from experience adjustments and changes in actuarial assumptions are charged or credited to equity in other comprehensive income in the period in which they arise.

The current service cost of the defined benefit plan is recognised in the income statement in employee benefit expense, except where included in the cost of an asset, and reflects the increase in the defined benefit obligation results from employee service in the current year benefit changes, curtailments and settlements.

Past-service costs are recognised immediately in the income statement.



## NOTES TO THE CONSOLIDATED FINANCIAL STATEMENTS

### 2 SUMMARY OF SIGNIFICANT ACCOUNTING POLICIES (Continued)

#### 2.18 Retirement obligations (Continued)

##### (b) *Defined benefit plans* (Continued)

The net interest cost is calculated by applying the discount rate to the net balance of the defined benefit obligation and the fair value of plan assets. This cost is included in employee benefit expense in the consolidated income statement.

#### 2.19 Current and deferred income tax

The tax expense for the period comprises current and deferred tax. Tax is recognised in the income statement, except to the extent that it relates to items recognised in other comprehensive income or directly in equity. In this case, the tax is also recognised in other comprehensive income or directly in equity, respectively.

##### (a) *Current income tax*

The current income tax charge is calculated on the basis of the tax laws enacted or substantively enacted at the balance sheet date in the countries where the Company's subsidiaries operate and generate taxable income. Management periodically evaluates positions taken in tax returns with respect to situations in which applicable tax regulation is subject to interpretation. It establishes provisions where appropriate on the basis of amounts expected to be paid to the tax authorities.

##### (b) *Deferred income tax*

###### (i) Inside basis differences

Deferred income tax is recognised, using the liability method, on temporary differences arising between the tax basis of assets and liabilities and their carrying amounts in the consolidated financial statements. Deferred income tax is determined using tax rates (and laws) that have been enacted or substantively enacted by the balance sheet date and are expected to apply when the related deferred income tax asset is realised or the deferred income tax liability is settled.

Deferred income tax assets are recognised only to the extent that it is probable that future taxable profit will be available against which the temporary differences can be utilised.

###### (ii) Outside basis differences

Deferred income taxes are not recorded on temporary differences arising on investments in subsidiaries and joint arrangements, except in situations where the timing of the reversal of the temporary difference is not controlled by the Group and it is probable that the temporary difference will reverse in the foreseeable future.

##### (c) *Offsetting*

Deferred income tax assets and liabilities are offset when there is a legally enforceable right to offset current tax assets against current tax liabilities and when the deferred income tax assets and liabilities relate to income taxes levied by the same taxation authority on either the taxable entity or different taxable entities where there is an intention to settle the balances on a net basis.

## NOTES TO THE CONSOLIDATED FINANCIAL STATEMENTS

### 2 SUMMARY OF SIGNIFICANT ACCOUNTING POLICIES (Continued)

#### 2.20 Provisions

Provisions for restructuring, legal disputes, environmental liabilities, warranties and decommissioning are recognised when: the Group has a present legal or constructive obligation as a result of past events; it is probable that an outflow of resources will be required to settle the obligation; and the amount has been reliably estimated. Restructuring provisions primarily comprise employee payments. Provisions are not recognised for future operating losses.

Provisions are measured at the present value of the expenditures expected to be required to settle the obligation using a pre-tax rate that reflects current market assessments of the time value of money and the risks specific to the obligation. The increase in the provision due to passage of time is recognised as interest expense.

#### 2.21 Trade payables

Trade payables are obligations to pay for goods or services that have been acquired in the ordinary course of business from suppliers. Trade payables are classified as current liabilities if payment is due within one year or less (or in the normal operating cycle of the business if longer). If not, they are presented as non-current liabilities.

Trade payables are recognised initially at fair value and subsequently measured at amortised cost using the effective interest method.

#### 2.22 Revenue recognition

Revenue is measured at the fair value of the consideration received, or receivable, less any trade discounts, sales returns and allowances allowed by the Group or any commercial incentives linked to sales. The Group recognises revenue when: the amount of revenue can be reliably measured; it is probable that future economic benefits will flow to the entity; and specific criteria have been met for each of the Group's activities, as described below. The Group contracts with customers which are generally OEMs in the automotive industry, to sell steering and driveline products. In connection with these contracts the Group also contracts to provide tooling, prototype, and engineering services. The revenue recognition policies applied by the Group for each of these activities are as follows:

(i) *Product*

Revenues are recognised when finished products are shipped to customers, both title and the risks and rewards of ownership are transferred, and collectability is reasonably assured.

(ii) *Prototype, engineering and pre-production*

Prototype, engineering and pre-production activities are only performed in connection with the development of products that will be produced for the customers. Consideration received from customers for engineering, prototyping and pre-production activity is deferred and recognised over the product life cycles of the related products.

(iii) *Tooling*

The Group's development and sale of tooling for customers is performed in connection with the preparations to produce and sell products to its customers. Therefore, consideration received from customers for tooling used in the production of the finished product is recognised as revenue at the time the tooling is accepted by the customers.

## NOTES TO THE CONSOLIDATED FINANCIAL STATEMENTS

### 2 SUMMARY OF SIGNIFICANT ACCOUNTING POLICIES (Continued)

#### 2.23 Leases

Leases in which a significant portion of the risks and rewards of ownership are retained by the lessor are classified as operating leases. Payments made under operating leases (net of any incentives received from the lessor) are charged to the income statement on a straight-line basis over the period of the lease. The Group's operating leases cover principally real estate, office and other equipment. Depending on the nature of the leased asset, the Group records lease expenses associated with operating leases within cost of sales, selling or administrative expenses on the income statement as appropriate.

The Group leases certain property, plant and equipment. Leases of property, plant and equipment where the Group has substantially all the risks and rewards of ownership are classified as finance leases. Finance leases are capitalised at the lease's commencement at the lower of the fair value of the leased property and the present value of the minimum lease payments.

Each finance lease payment is allocated between the liability and finance charges. The corresponding rental obligations, net of finance charges, are included in other long-term payables. The interest element of the finance cost is charged to the income statement over the lease period so as to produce a constant periodic rate of interest on the remaining balance of the liability for each period. The property, plant and equipment acquired under finance leases is depreciated over the shorter of the useful life of the asset and the lease term.

#### 2.24 Share-based payment

The Group established an equity-settled, share-based compensation plan in June 2014, under which the Group receives services from certain employees as consideration for equity instruments (options) of the Group. The fair value of the employee services received in exchange for the grant of the options is recognised as an expense. The total amount to be expensed is determined by reference to the fair value of the options granted, excluding the impact of any service and non-market performance vesting conditions (for example, profitability, sales growth targets and retaining an employee of the entity over a specified time period).

Non-market performance and service conditions are included in assumptions about the number of options that are expected to vest. The total expense is recognised over the vesting period, which is the period over which all of the specified vesting conditions are to be satisfied.

At the end of each reporting period, the Group revises its estimates of the number of options that are expected to vest based on the non-marketing performance and service conditions. It recognises the impact of the revision to original estimates, if any, in the income statement, with a corresponding adjustment to equity.

When the options are exercised, the Group issues new shares. The proceeds received net of any directly attributable transaction costs are credited to share capital (nominal value) and share premium.

#### 2.25 Government grants

The Group periodically receives government grants in support of various business initiatives. Grants from the government are recognised at their fair value where there is a reasonable assurance that the grant will be received and the Group will comply with all attached conditions. Government grants used to purchase, construct or otherwise acquire property, plant and equipment or tooling are deducted from the cost of the related asset. Government grants that are receivable as compensation for expenses or losses already incurred or for the purpose of giving immediate financial support to the Group with no future related costs are recognised as income of the period in which they become receivable.

## NOTES TO THE CONSOLIDATED FINANCIAL STATEMENTS

**2 SUMMARY OF SIGNIFICANT ACCOUNTING POLICIES** (Continued)**2.26 Dividend distribution**

Dividend distribution to the Company's shareholders is recognised as a liability in the Group's and the Company's financial statements in the period in which the dividends are approved by the Company's shareholders or directors, where appropriate.

**2.27 Revision of prior year statements**

During the second half of 2015, the Company revised the consolidated balance sheet as at December 31, 2014 to adjust for the netting of non-current deferred income tax assets and liabilities by tax jurisdiction of US\$19,941,000. Management does not consider this reclassification is material to the Company's consolidated financial statements. The revision had no impact on the consolidated income statement, consolidated statement of comprehensive income, consolidated statement of changes in equity or consolidated statement of cash flows. The impact of adjusting the consolidated balance sheet for this specified period is as follows:

	<b>As Previously Reported</b> US\$'000	<b>Adjustments</b> US\$'000	<b>As Revised</b> US\$'000
<b>As at December 31, 2014</b>			
Non-current deferred income tax assets	29,908	(19,941)	9,967
Non-current deferred income tax liabilities	42,696	(19,941)	22,755

**2.28 New/revised standards, amendments to standards and interpretations***(a) New and amended standards adopted by the Group*

The following are the standards applicable to the Group that have been adopted for the first time for the financial year beginning on January 1, 2015:

- Amendment to IAS 19 regarding defined benefit plans: employee contributions applies to contributions from employees or third parties to defined benefit plans. The amendment distinguishes between contributions that are linked to service only in the period in which they arise and those linked to service in more than one period. The amendment allows contributions that are linked to service, and do not vary with the length of employee service, to be deducted from the cost of benefits earned in the period that the service is provided. Contributions that are linked to service, and vary according to the length of employee service, must be spread over the service period using the same attribution method that is applied to the benefits.
- Annual improvements 2010-2012 and 2011-2013 cycles which provide clarification of requirements related to vesting conditions within IFRS 2 Share-based Payments, accounting for contingent consideration in a business combination within IFRS 3 Business Combinations, aggregation and reconciliation of operating segments within IFRS 8 Operating Segments, measurement of short-term receivables and payables within IFRS 13 Fair Value Measurement, restatement of accumulated depreciation under the revaluation method within IAS 16 Property, Plant, and Equipment, key management personnel disclosures within IAS 24 Related Parties, and restatement of accumulated amortisation under the revaluation method within IAS 38 Intangible Assets.

The adoption of the above amendments does not have any significant financial effect on the consolidated financial statements.

## NOTES TO THE CONSOLIDATED FINANCIAL STATEMENTS

### 2 SUMMARY OF SIGNIFICANT ACCOUNTING POLICIES (Continued)

#### 2.28 New/revised standards, amendments to standards and interpretations (Continued)

##### (b) *New and amended standards and interpretations not yet adopted*

The following are the new standards, amendments to standards and interpretations that are applicable to the Group, are effective for annual periods beginning on or after January 1, 2016 and have not been applied in these financial statements.

- Amendments to IAS 1 for the disclosure initiative (effective for annual periods beginning on or after January 1, 2016) clarify guidance in IAS 1 on materiality and aggregation, the presentation of subtotals, the structure of financial statements and the disclosure of accounting policies.
- IFRS 15, 'Revenue from contracts with customers' (effective for annual periods beginning on or after January 1, 2018) deals with revenue recognition and establishes principles for reporting useful information to users of financial statements about the nature, amount, timing and uncertainty of revenue and cash flows arising from an entity's contracts with customers. Revenue is recognised when a customer obtains control of a good or service and thus has the ability to direct the use and obtain the benefits from the good or service. The standard replaces IAS 18 'Revenue' and IAS 11 'Construction Contracts' and related interpretations.
- IFRS 9 'Financial instruments' (effective for annual periods beginning on or after January 1, 2018) addresses the classification, measurement and recognition of financial assets and financial liabilities. IFRS 9 requires financial assets to be classified into two measurement categories: those measured at fair value and those measured at amortised cost. For financial liabilities, the standard retains most of the IAS 39 requirements.
- Annual Improvements Cycle 2012-2014 (effective for annual periods beginning on or after January 1, 2016) include clarifications related to the following: IFRS 5 Changes in methods of disposal, IFRS 7 Servicing contracts, IFRS 7 Applicability of the amendments to IFRS 7 to condensed interim financial statements, IAS 19 Regional market issue, and IAS 34 Disclosure of information elsewhere in the interim financial report.
- IFRS 16 'Leases' (effective for annual periods beginning on or after January 1, 2019) specifies how to recognise, measure, present, and disclose leases. The standard provides a single lessee model, requiring lessees to recognise assets and liabilities for all leases unless the lease term is twelve months or less or the underlying asset has a low value. Lessors will continue to classify leases as operating or finance according to IAS 17.

The Group is assessing the impact of these changes.

##### (c) *New Hong Kong Companies Ordinance (Cap. 622)*

In addition, the requirements of Part 9 'Accounts and Audit' of the new Hong Kong Companies Ordinance (Cap. 622) come into operation during the financial year, as a result, there are changes to presentation and disclosures of certain information in the consolidated financial statements.

## NOTES TO THE CONSOLIDATED FINANCIAL STATEMENTS

**3 FINANCIAL RISK MANAGEMENT****3.1 Financial risk factors**

The Group's activities expose it to a variety of financial risks: market risk (including foreign exchange risk, cash flow interest rate risk and price risk), credit risk and liquidity risk. The Group's overall risk management program focuses on the unpredictability of financial markets and seeks to minimise potential adverse effects on the Group's financial performance.

The Group's risk management and treasury department focuses on minimising potential adverse effects on the Group's financial performance. The Group uses derivative financial instruments to hedge certain risk exposures.

*(a) Market risk*

The objective of market risk management is to manage and control market risk exposures within acceptable parameters while optimising the return.

*(i) Foreign exchange risk*

The Group operates internationally and is exposed to foreign exchange risk arising from various currency exposures, primarily with respect to the Euro, Polish Zloty, Mexican Peso, and Chinese Renminbi ('RMB').

As at each year end, excluding transactional foreign exchange differences, if US dollar strengthened by 10% against Euro/RMB with all other variables held constant, the equity and post-tax result for each year would have decreased mainly as a result of foreign exchange differences on translation of Euro/RMB denominated assets and liabilities:

	<b>Equity</b> US\$'000	<b>Post-tax result</b> US\$'000
<b>As at and for the year ended December 31, 2015</b>		
Euro	33,203	801
RMB	24,954	6,030
<b>As at and for the year ended December 31, 2014</b>		
Euro	20,908	2,789
RMB	16,499	3,950

A weakening of the US dollar against the above currencies would have had equal but opposite effect to the amounts shown above, on the basis that all other variables remain constant.

Management monitors and analyses expected exchange rate developments and considers hedging foreign currency exposure should the need arise. The Group has entered into forward exchange contracts to hedge currency exposure between the Mexican peso and the US dollar, the Polish zloty and the US dollar, and the Euro and the US dollar.



## NOTES TO THE CONSOLIDATED FINANCIAL STATEMENTS

### 3 FINANCIAL RISK MANAGEMENT (Continued)

#### 3.1 Financial risk factors (Continued)

##### (a) Market risk (Continued)

##### (ii) Cash flow interest rate risk

The Group's interest rate risk primarily arises from current and non-current borrowings. Changes in interest rates on borrowings issued at variable rates potentially expose the Group to cash flow interest rate risk. Borrowings obtained at fixed rates expose the Group to fair value interest rate risk. The Group manages certain of its cash flow interest rate risk by using a floating to fixed interest rate swap and assessing the ratio of floating to fixed rate borrowings. Inclusive of the interest rate swap, as at December 31, 2015, 56.6% (December 31, 2014: 60%) of the Group's borrowings were in floating rate instruments. In the event there is a change in market conditions the Group will assess moving from primarily variable to fixed rate borrowings.

As at December 31, 2015, if the interest rates had been 100 basis points higher/(lower) than the prevailing rate, with all other variables held constant, net profit for the year ended December 31, 2015 would have been US\$4,161,000 (2014: US\$5,143,000) lower/(higher).

##### (iii) Price risk

Price risk relates to changes in the price of raw materials purchased for production from time of price quotation to customers and production of saleable parts. The Group manages this risk primarily by negotiating recoveries from customers.

##### (b) Credit risk

The Group sells to automotive manufacturers throughout the world. Credit risk arises from deposits and derivative financial instruments with banks and financial institutions as well as credit exposures to customers, including outstanding receivables. The treasury department is responsible for managing and analysing the credit risk for each new customer before standard payment and delivery terms and conditions are offered. The customer's creditworthiness is assessed at the local level through analysing past due receivables.

The Group's largest customer is General Motors and its subsidiaries ('General Motors Group') and its affiliates which comprised 47.7% of net sales during the year ended December 31, 2015 (2014: 54%). Trade receivables from General Motors Group and its affiliates was 33% of total trade receivables as at December 31, 2015 (December 31, 2014: 37%).

The Group monitors the credit ratings of its banks and financial institutions. As at December 31, 2015, the Group holds approximately 91% (December 31, 2014: 85%) of its cash in financial institutions with credit ratings of A3 (Moody's) or higher meaning the institutions have a very strong to extremely strong capacity to meet financial commitments. The remainder of cash is held in banks within investment grade.

## NOTES TO THE CONSOLIDATED FINANCIAL STATEMENTS

**3 FINANCIAL RISK MANAGEMENT** (Continued)**3.1 Financial risk factors** (Continued)*(c) Liquidity risk*

The Group monitors forecasts of liquidity requirements to ensure it has sufficient cash to meet operational needs, while maintaining sufficient availability on its undrawn committed borrowing facilities at all times as to not breach borrowing limits or covenants (where applicable) on any of its facilities. The Group's forecasting takes into consideration debt financing plans, covenant compliance, and if applicable, external regulatory or legal requirements.

The tables below analyses the Group's non-derivative financial liabilities into relevant maturity groups based on the remaining period at the balance sheet date to the contractual maturity date. The amounts disclosed are the contractual undiscounted cash flows.

	<b>Within 1 year US\$'000</b>	<b>1–2 years US\$'000</b>	<b>2–5 years US\$'000</b>	<b>Over 5 years US\$'000</b>
<b>As at December 31, 2015</b>				
Short-term borrowings	6,038	–	–	–
Long-term borrowings	104,745	101,875	297,083	264,061
Finance lease obligations	879	610	749	–
	<b>111,662</b>	<b>102,485</b>	<b>297,832</b>	<b>264,061</b>
Trade payables	558,769	–	–	–
Other payables and accruals	97,562	7,174	–	–
	<b>656,331</b>	<b>7,174</b>	<b>–</b>	<b>–</b>
	Within 1 year US\$'000	1–2 years US\$'000	2–5 years US\$'000	Over 5 years US\$'000
<b>As at December 31, 2014</b>				
Short-term borrowings	21,909	–	–	–
Long-term borrowings	107,297	102,569	319,646	323,601
Finance lease obligations	415	287	30	–
	<b>129,621</b>	<b>102,856</b>	<b>319,676</b>	<b>323,601</b>
Trade payables	438,975	–	–	–
Other payables and accruals	77,341	7,908	–	–
	<b>516,316</b>	<b>7,908</b>	<b>–</b>	<b>–</b>

## NOTES TO THE CONSOLIDATED FINANCIAL STATEMENTS

**3 FINANCIAL RISK MANAGEMENT** (Continued)**3.2 Capital management**

The Group's objectives when managing capital are to safeguard the Group's ability to continue as a going concern in order to provide returns for shareholders and maintain an optimal capital structure to reduce the cost of capital. The Group monitors the gearing ratio to evaluate capital efficiency. Gearing ratio is a rate of total borrowings divided by total equity at the end of each year, and is displayed as follows:

	<b>As at December 31,</b>	
	<b>2015</b>	2014
	<b>US\$'000</b>	US\$'000
Total borrowings (note 17)	641,723	730,982
Total equity	854,365	708,019
Gearing ratio	75.1%	103.2%

**3.3 Fair value estimation**

The carrying amounts of the Group's current financial assets and liabilities, including cash and cash equivalents, restricted bank deposits, trade and other receivables, trade and other payables and current borrowings approximate their fair values. The fair value of financial liabilities for disclosure purposes is estimated by discounting the future contractual cash flows at the current market interest rate available to the Group for similar financial instruments.

The table below analyses financial instruments carried at fair value, by valuation method. The different levels have been defined as follows:

- Quoted prices (unadjusted) in active markets for identical assets or liabilities (level 1)
- Inputs other than quoted prices included within level 1 that are observable for the asset or liability, either directly (that is, as prices) or indirectly (that is, derived from prices) (level 2)
- Inputs for the asset or liability that are not based on observable market data (that is, unobservable inputs) (level 3)

## NOTES TO THE CONSOLIDATED FINANCIAL STATEMENTS

**3 FINANCIAL RISK MANAGEMENT** (Continued)**3.3 Fair value estimation** (Continued)

The following table presents the Group's assets and (liabilities) that are measured at fair value at December 31, 2015 and 2014:

	Level 1 US\$'000	Level 2 US\$'000	Level 3 US\$'000	Total US\$'000
<b>As at December 31, 2015</b>				
Forward foreign exchange contracts, net	–	(5,213)	–	(5,213)
Interest rate swap	–	(6)	–	(6)
<b>As at December 31, 2014</b>				
Forward foreign exchange contracts, net	–	(3,971)	–	(3,971)
Interest rate swap	–	(56)	–	(56)

The fair value of financial instruments traded in active markets is based on quoted market prices at the balance sheet date. A market is regarded as active if quoted prices are readily and regularly available from an exchange, dealer, broker, industry group, pricing service, or regulatory agency, and those prices represent actual and regularly occurring market transactions on an arm's length basis. The quoted market price used for financial assets held by the Group is the current bid price. These instruments are included in level 1.

The fair value of financial instruments that are not traded in an active market is determined by using valuation techniques. These valuation techniques maximise the use of observable market data where it is available and rely as little as possible on entity specific estimates. If all significant inputs required to fair value an instrument are observable, the instrument is included in level 2.

If one or more of the significant inputs is not based on observable market data, the instrument is included in level 3.

There were no transfers of financial assets between fair value hierarchy classifications.

**4 CRITICAL ACCOUNTING ESTIMATES AND JUDGEMENTS**

Estimates and judgements are continually evaluated and are based on historical experience and other factors, including expectations of future events that are believed to be reasonable under the circumstances.

The Group makes estimates and assumptions concerning the future. The resulting accounting estimates will, by definition, seldom equal the related actual results. The estimates and assumptions that have a significant risk of causing a material adjustment to the carrying amounts of assets and liabilities are addressed below.

**(a) Intangible assets not available for use***(i) Capitalisation*

Costs incurred on development projects are recognised as intangible assets when it is probable that the projects will be successful considering the criteria set out in note 2.8. The Group's development activities are tracked by its engineering department and documented to support the basis of determining if and when the criteria were met.

## NOTES TO THE CONSOLIDATED FINANCIAL STATEMENTS

### 4 CRITICAL ACCOUNTING ESTIMATES AND JUDGEMENTS (Continued)

#### (a) Intangible assets not available for use (Continued)

##### (ii) Impairment

The Group is required to test intangible development assets not available for use on an annual basis. Other non-financial assets are tested whenever events or changes in circumstances indicate that the carrying amount of those assets exceeds its recoverable amount. The recoverable amount is determined based on the higher of fair value less cost to sell and value in use.

Determination of the value in use is an area involving management judgement in order to assess whether the carrying value of the intangible development assets not available for use can be supported by the net present value of future cash flows. In calculating the net present value of the future cash flows, certain assumptions are required to be made in respect of highly uncertain matters including management's expectations of (I) future unlevered free cash flows; (II) long-term growth rates; and (III) the selection of discount rates to reflect the risks involved.

The Group prepares and approves formal five-year management plans for its operations, which are used in estimating the value in use of the assets or cash generating units being tested. Changing the assumptions selected by management, in particular the discount rate and growth rate assumptions used in the cash flow projections, could significantly affect the outcome of the Group's impairment evaluation.

The Group uses the most recent detailed calculation of that asset's recoverable amount made in a preceding period when all of the following criteria are met: (I) the assets and liabilities of the Group have not changed significantly from the most recent calculation; (II) the most recent calculation resulted in an amount that exceeded the asset's carrying amount by a substantial margin; and (III) based on an analysis of events that have occurred and circumstances that have changed since the most recent calculation, the likelihood that a current recoverable amount determination would be less than the asset's carrying amount is remote.

#### (b) Retirement benefits

The costs, assets and liabilities of the defined benefit plans operated by the Group are determined using methods relying on actuarial estimates and assumptions. Details of the key assumptions and the sensitivity analysis of such assumptions are set out in note 18. Changes in the assumptions used may have a significant effect on the statement of comprehensive income and the balance sheet.

#### (c) Provisions

The Group recognises a provision when there is a present obligation from a past event, a transfer of economic benefits is probable and the amount of costs of the transfer can be estimated reliably. In instances where these criteria are not met, a contingent liability may be disclosed in the notes to the financial statements. Obligations arising in respect of contingent liabilities that have been disclosed, or those which are not currently recognised or disclosed in the financial statements could have a material effect on the Group's financial position. Application of these accounting principles to legal cases requires the Group's management to make determinations about various factual and legal matters beyond its control.

##### (i) Litigation

From time to time the Group is subject to various legal actions and claims incidental to its business, including those arising out of alleged defects, breach of contracts, intellectual property matters, and employment related matters.

The Group believes its established reserves are adequate to cover such items. However, the final amounts required to resolve these matters could differ materially from recorded estimates.

Litigation is subject to many uncertainties and the outcome of the individual litigated matters is not predictable with assurance. Based on currently available information, it is the opinion of management that the outcome of such matters will not have a material adverse impact on the Group.

## NOTES TO THE CONSOLIDATED FINANCIAL STATEMENTS

**4 CRITICAL ACCOUNTING ESTIMATES AND JUDGEMENTS** (Continued)**(c) Provisions** (Continued)*(ii) Environmental liabilities*

The Group records environmental liabilities based upon estimates of financial exposure with respect to environmental sites. Environmental requirements may become more stringent over time or eventual environmental cleanup costs and liabilities may ultimately exceed current estimates. Moreover, future facilities sales could trigger additional, perhaps material, environmental remediation costs, as previously unknown conditions may be identified.

*(iii) Warranties*

The Group recognises expected warranty costs for products sold principally at the time of sale of the product or when it is determined that such obligations are probable and can be reasonably estimated. Amounts recorded are based on the Group's estimates of the amount that will eventually be required to settle such obligations. These accruals are based on factors such as specific customer arrangements, past experience, production changes, industry developments and various other considerations. The Group's estimates are adjusted from time to time based on facts and circumstances that impact the status of existing claims.

*(iv) Decommissioning*

The Group identified conditional asset retirement obligations primarily relate to asbestos abatement and removal and disposal of storage tanks at certain of our sites. Amounts recorded are based on the Group's estimate of future obligations to leave or close a facility. Sites are continually monitored for changes that may impact future obligations for decommissioning. The Group records accretion expense monthly to account for discounting of such obligations.

**(d) Income taxes**

The Group is subject to income taxes in numerous jurisdictions. Significant judgement is required in determining the worldwide provision for income taxes. There are many transactions and calculations for which the ultimate tax determination is uncertain. The Group recognises liabilities for anticipated tax audit issues based on estimates of whether additional taxes will be due. The Group believes that its accruals for tax liabilities are adequate for all open audit years based on its assessment of many factors including past experience and interpretations of tax law. This assessment relies on estimates and assumptions and may involve a series of complex judgements about future events. Where the final tax outcome of these matters is different from the amounts that were initially recorded, such differences will impact the current and deferred income tax assets and liabilities in the period in which such determination is made.

Deferred tax assets are recognised only if it is probable that taxable profits will be available against which the deductible temporary differences can be utilised. This determination requires significant judgement regarding the realisability of deferred tax assets. For entities with a recent history of losses, there would need to be convincing other evidence that sufficient taxable profits would be available in the future. When the expectation is different from the original estimate, such differences will impact the recognition of deferred income tax assets and taxation charges in the period in which such estimate is changed.

**(e) Share-based payment**

In determining the fair value of the share option scheme, considerable judgement is required to interpret market data used in the valuation techniques. The use of different market assumptions and/or estimation methodologies may have a material effect on the estimated fair value amounts.

**(f) Fair value of derivatives**

The fair value of financial instruments that are not traded in an active market is determined by using valuation techniques. The Group uses its judgement to select from a variety of methods and make assumptions that are mainly based on market conditions existing at the end of each reporting period.



## NOTES TO THE CONSOLIDATED FINANCIAL STATEMENTS

### 5 SEGMENT INFORMATION

The Group's segment information is presented on the basis of internal reports that are regularly reviewed by the Group's CEO, in order to allocate resources to the segments and assess their performance. For each of the Group's reportable segments, the Group's CEO reviews internal management reports on a quarterly basis, at a minimum.

The Group classifies its businesses into four reportable segments: North America, China, Europe and Rest of World. All of the Group's operating segments typically offer the same driveline and steering products. The 'Others' category represents parent company activities of the Company and its non-operating direct and indirect subsidiaries, as well as elimination entries between segments.

The key performance indicators that the Group monitors to manage segment operations are:

- Adjusted EBITDA, which represents operating income before interest, taxes, depreciation and amortisation and share of results of a joint venture.
- Total assets and total liabilities represent total current and non-current assets and total current and non-current liabilities of the segments and include assets and liabilities between operating segments. During the year ended December 31, 2015 the Group changed its balance sheet metric reported to the chief operating decision maker from net working capital which represented inventory and trade receivables net of trade payables to total assets and total liabilities.

Information about reportable segments and reconciliations of reportable segment revenues is as follows:

	North America US\$'000	China US\$'000	Europe US\$'000	Rest of World US\$'000	Others US\$'000	Total US\$'000
<b>For the year ended December 31, 2015</b>						
Total revenue	2,256,961	742,703	350,320	86,423	–	3,436,407
Inter-segment revenue	(40,112)	(9,967)	(10,174)	(15,642)	–	(75,895)
Revenue from external customers	2,216,849	732,736	340,146	70,781	–	3,360,512
Adjusted EBITDA	337,075	108,029	22,393	(10,391)	(1,696)	455,410
<b>For the year ended December 31, 2014</b>						
Total revenue	2,082,418	475,349	380,305	119,352	–	3,057,424
Inter-segment revenue	(40,443)	(7,257)	(17,114)	(14,542)	–	(79,356)
Revenue from external customers	2,041,975	468,092	363,191	104,810	–	2,978,068
Adjusted EBITDA	232,176	72,431	43,253	1,217	6,640	355,717

Revenue between segments are carried out at arm's length. The revenue from external parties reported to the Group's CEO is measured in a manner consistent with that in the income statement.

## NOTES TO THE CONSOLIDATED FINANCIAL STATEMENTS

## 5 SEGMENT INFORMATION (Continued)

	North America US\$'000	China US\$'000	Europe US\$'000	Rest of World US\$'000	Others US\$'000	Total US\$'000
<b>As at December 31, 2015</b>						
Total assets	1,546,181	617,275	312,412	69,068	(88,114)	2,456,822
Total liabilities	(842,635)	(367,744)	(112,545)	(31,272)	(248,261)	(1,602,457)
<b>As at December 31, 2014</b>						
Total assets	1,299,664	463,398	333,672	94,953	30,285	2,221,972
Total liabilities	(720,901)	(298,407)	(124,022)	(32,285)	(338,338)	(1,513,953)

Reconciliations of reportable segment adjusted EBITDA to those as determined under IFRS are as follows:

	For the year ended December 31,	
	2015 US\$'000	2014 US\$'000
Adjusted EBITDA from reportable segments	455,410	355,717
Depreciation and amortisation expenses	(142,280)	(118,821)
Finance costs, net	(30,951)	(21,583)
Share of income/(loss) of a joint venture	1,185	(717)
Profit before income tax	283,364	214,596

In presenting information on the basis of geography, segment revenue is based on the geographical location of subsidiaries and segment assets are based on geographical location of the assets.

Adjusted EBITDA includes a non-cash component for deferred revenue amortisation. For the year ended December 31, 2015, the North America segment and China segment recognised US\$21,603,000 (2014: US\$15,758,000) and US\$1,686,000 (2014: US\$1,317,000).

The geographic distribution of revenue for the years ended December 31, 2015 and 2014 is as follows:

	For the year ended December 31,	
	2015 US\$'000	2014 US\$'000
North America		
US	1,532,730	1,415,723
Mexico	684,119	626,252
Europe:		
Poland	333,269	357,336
Rest of Europe	6,877	5,855
China	732,736	468,092
Rest of World	70,781	104,810
	3,360,512	2,978,068

## NOTES TO THE CONSOLIDATED FINANCIAL STATEMENTS

**5 SEGMENT INFORMATION** (Continued)

The geographic distribution of non-current assets excluding deferred income tax assets as at December 31, 2015 and 2014 respectively is as follows:

	<b>As at December 31,</b>	
	<b>2015</b>	2014
	<b>US\$'000</b>	US\$'000
North America		
US	708,403	632,804
Mexico	111,834	96,997
Europe:		
Poland	99,384	87,109
Rest of Europe	2,661	2,819
China	174,104	151,831
Rest of World	13,203	14,935
	<b>1,109,589</b>	<b>986,495</b>

Distribution of revenue between product lines for the years ended December 31, 2015 and 2014 is as follows:

	<b>For the year ended</b>		For the year ended	
	<b>December 31, 2015</b>		December 31, 2014	
	<b>US\$'000</b>	%	US\$'000	%
Steering				
EPS	2,000,287	59.5	1,668,140	56.0
HPS	167,337	5.0	183,054	6.1
CIS	609,565	18.1	583,082	19.6
Driveline	583,323	17.4	543,792	18.3
	<b>3,360,512</b>	<b>100.0</b>	<b>2,978,068</b>	<b>100.0</b>

Revenues from customers amounting to 10 percent or more of the Group's revenue are as follows and reported in all segments:

	<b>For the year ended</b>	
	<b>December 31,</b>	2014
	<b>2015</b>	US\$'000
	<b>US\$'000</b>	US\$'000
General Motors Group and its affiliates	1,604,355	1,604,536
Customer A	582,043	501,362
Customer B	456,957	303,798
	<b>2,643,355</b>	<b>2,409,696</b>

## NOTES TO THE CONSOLIDATED FINANCIAL STATEMENTS

## 6 PROPERTY, PLANT AND EQUIPMENT

	Freehold land and land improvements US\$'000	Leasehold improvement US\$'000	Buildings US\$'000	Machinery, equipment and tooling US\$'000	Furniture and office equipment US\$'000	Construction in progress US\$'000	Total US\$'000
<b>As at January 1, 2014</b>							
Cost	8,809	3,465	27,941	574,820	1,693	96,413	713,141
Accumulated depreciation	(1,668)	(951)	(8,276)	(139,121)	(585)	–	(150,601)
Net book amount	7,141	2,514	19,665	435,699	1,108	96,413	562,540
<b>Year ended December 31, 2014</b>							
Opening net book amount	7,141	2,514	19,665	435,699	1,108	96,413	562,540
Additions/(transfers upon completion)	108	2,390	3,473	171,405	1,309	(12,798)	165,887
Disposals	(159)	(45)	(18)	(6,651)	(9)	(555)	(7,437)
Depreciation	(297)	(682)	(899)	(77,898)	(482)	–	(80,258)
Exchange differences	(284)	(160)	(416)	(12,527)	(131)	(1,290)	(14,808)
Net book amount as at December 31, 2014	6,509	4,017	21,805	510,028	1,795	81,770	625,924
<b>As at January 1, 2015</b>							
Cost	8,416	5,570	30,068	715,655	2,800	81,770	844,279
Accumulated depreciation	(1,907)	(1,553)	(8,263)	(205,627)	(1,005)	–	(218,355)
Net book amount	6,509	4,017	21,805	510,028	1,795	81,770	625,924
<b>Year ended December 31, 2015</b>							
Opening net book amount	6,509	4,017	21,805	510,028	1,795	81,770	625,924
Additions/(transfers upon completion)	1	2,714	4,128	166,684	492	(1,368)	172,651
Disposals	–	(5)	(528)	(5,450)	(6)	–	(5,989)
Depreciation	(95)	(1,220)	(1,368)	(85,727)	(427)	–	(88,837)
Exchange differences	(434)	(164)	(1,598)	(14,097)	(124)	(2,057)	(18,474)
Net book amount as at December 31, 2015	5,981	5,342	22,439	571,438	1,730	78,345	685,275
<b>As at December 31, 2015</b>							
Cost	7,821	7,974	32,602	851,164	2,951	78,345	980,857
Accumulated depreciation	(1,840)	(2,632)	(10,163)	(279,726)	(1,221)	–	(295,582)
Net book amount	5,981	5,342	22,439	571,438	1,730	78,345	685,275

## NOTES TO THE CONSOLIDATED FINANCIAL STATEMENTS

**6 PROPERTY, PLANT AND EQUIPMENT** (Continued)

Certain of the Group's property, plant and equipment have been pledged as collateral under the Group's borrowing arrangements. The carrying amounts of property, plant and equipment pledged as collateral were US\$524,485,000 as at December 31, 2015 (December 31, 2014: US\$479,406,000).

Property, plant and equipment at December 31, 2015 included equipment under finance lease of US\$2,067,000 (December 31, 2014: US\$844,000), including accumulated depreciation of US\$1,274,000 (December 31, 2014: US\$1,020,000).

Depreciation has been charged to the following function of expenses:

	For the year ended	
	December 31, 2015	2014
	US\$'000	US\$'000
Cost of sales	82,858	76,260
Engineering and product development costs	4,430	2,683
Administrative expenses	1,549	1,315
	<b>88,837</b>	<b>80,258</b>

The additions for the year ended December 31, 2015 include US\$331,000 of capitalised borrowing costs (2014: US\$nil). Borrowing costs were capitalised at the weighted average of the borrowing rate of 4.4% for the year ended December 31, 2015 (2014: 4.3%).

**7 LAND USE RIGHTS**

	For the year ended	
	December 31, 2015	2014
	US\$'000	US\$'000
<b>Cost</b>		
As at January 1	1,021	1,036
Exchange differences	(45)	(15)
As at December 31	<b>976</b>	<b>1,021</b>
<b>Accumulated amortisation</b>		
As at January 1	332	304
Amortisation	25	25
Exchange differences	(15)	3
	<b>342</b>	<b>332</b>
<b>Net book amount</b>		
As at December 31	<b>634</b>	<b>689</b>

## NOTES TO THE CONSOLIDATED FINANCIAL STATEMENTS

## 8 INTANGIBLE ASSETS

	<b>Product development costs</b> US\$'000	<b>Computer software development costs</b> US\$'000	<b>Total</b> US\$'000
<b>Cost</b>			
As at January 1, 2014	287,249	6,107	293,356
Additions	102,064	9,198	111,262
Exchange differences	–	–	–
As at December 31, 2014	389,313	15,305	404,618
<b>Accumulated amortisation</b>			
As at January 1, 2014	21,998	–	21,998
Amortisation	38,339	199	38,538
Exchange differences	255	–	255
As at December 31, 2014	60,592	199	60,791
<b>Net book amount</b>			
As at December 31, 2014	328,721	15,106	343,827
<b>Cost</b>			
As at January 1, 2015	389,313	15,305	404,618
Additions	109,287	8,761	118,048
Exchange differences	(883)	–	(883)
As at December 31, 2015	497,717	24,066	521,783
<b>Accumulated amortisation</b>			
As at January 1, 2015	60,592	199	60,791
Amortisation	50,906	2,512	53,418
Exchange differences	(97)	–	(97)
As at December 31, 2015	111,401	2,711	114,112
<b>Net book amount</b>			
As at December 31, 2015	386,316	21,355	407,671

The additions for the year ended December 31, 2015 include US\$5,188,000 of capitalised interest related to the borrowings associated with developmental costs (2014: US\$4,660,000). Borrowing costs were capitalised at the weighted average of the borrowing rate of 4.4% for the year ended December 31, 2015 (2014: 4.3%).



## NOTES TO THE CONSOLIDATED FINANCIAL STATEMENTS

**8 INTANGIBLE ASSETS** (Continued)

Amortisation has been charged to the following function of expenses:

	For the year ended December 31,	
	2015 US\$'000	2014 US\$'000
Cost of sales	50,906	38,339
Administrative expenses	2,512	199
	<b>53,418</b>	<b>38,538</b>

**Impairment tests**

Capitalised product development costs not yet available for use are tested annually based on the recoverable amount of the cash generating unit to which the intangible asset is related.

The recoverable amount of the cash generating units was determined based upon value in use from the most recent detailed calculations. The value in use was estimated using the discounted cash flow approach. For significant cash generating units, the pretax discount rates used to estimate future cash flows between 13.0% and 20.0% which are based on an estimated weighted average cost of capital depending on geographical location and risk factors and includes estimates of country risk premiums. Estimated cash flows are based on the estimated useful life of the cash generating unit.

In determining value in use it is necessary to make a series of assumptions to estimate future cash flows. There is risk in future profitability such as customer volumes and commodity pricing. The assumptions for customer volumes and commodity pricing are reviewed annually as part of the management's budgeting and strategic planning cycles.

The assumptions related to customer volume and timing of sales to customers may vary due to a number of factors, including variation in demand for customers' products, customers' attempts to manage their inventories, design changes, changes in customers' manufacturing strategy, etc. Accordingly, many of the Group's customers do not commit to long term production schedules.

The assumptions related to commodity pricing may vary as raw material costs are influenced by several commodities and the volatility of these prices may have an adverse impact on the Group's business. However, to mitigate the risk the Group continues its efforts to pass material, component, and supply cost increases to the Group's customers.

## NOTES TO THE CONSOLIDATED FINANCIAL STATEMENTS

**9 DEFERRED INCOME TAXES**

The analysis of deferred income tax assets and deferred income tax liabilities is as follows:

	<b>As at December 31,</b>	
	<b>2015</b>	2014
	<b>US\$'000</b>	US\$'000
<b>Deferred income tax assets:</b>		
– To be recovered after more than 12 months	5,655	6,286
– To be recovered within 12 months	24,725	23,622
	<b>30,380</b>	29,908
<b>Deferred income tax liabilities:</b>		
– To be settled after more than 12 months	(70,800)	(42,696)
– To be settled within 12 months	–	–
	<b>(70,800)</b>	(42,696)
<b>Deferred income tax liabilities, net</b>	<b>(40,420)</b>	(12,788)

The reconciliation of deferred income tax liabilities, net to the Consolidated Balance Sheet is as follows:

	<b>As at December 31,</b>	
	<b>2015</b>	2014
	<b>US\$'000</b>	US\$'000
Deferred income tax assets	11,083	9,967
Deferred income tax liabilities	(51,503)	(22,755)
Deferred income tax liabilities, net	<b>(40,420)</b>	(12,788)

## NOTES TO THE CONSOLIDATED FINANCIAL STATEMENTS

**9 DEFERRED INCOME TAXES** (Continued)

The movement in deferred income tax assets and liabilities during the year, without taking into consideration the offsetting of balances within the same tax jurisdiction, is as follows:

	Property, plant and equipment US\$'000	Retirement benefits and compensations US\$'000	Provisions and accruals US\$'000	Tax losses and credits US\$'000	Intangible assets US\$'000	Others US\$'000	Total US\$'000
<b>Deferred income tax assets</b>							
As at January 1, 2014	3,826	14,010	56,621	18,281	121	10,895	103,754
Credit/(Charged) to income statement	1,174	2,010	19,765	(8,675)	(121)	257	14,410
Credit/(Charged) to other comprehensive income	-	794	(4,375)	-	-	-	(3,581)
Exchange differences	(225)	(164)	(260)	(35)	-	(52)	(736)
As at December 31, 2014	4,775	16,650	71,751	9,571	-	11,100	113,847
As at January 1, 2015	4,775	16,650	71,751	9,571	-	11,100	113,847
(Charged)/Credit to income statement	(229)	(1,788)	3,765	(5,699)	-	947	(3,004)
(Charged)/Credit to other comprehensive income	-	(342)	(3,237)	-	-	-	(3,579)
Exchange differences	(115)	(89)	(167)	(21)	-	(37)	(429)
As at December 31, 2015	4,431	14,431	72,112	3,851	-	12,010	106,835
<b>Deferred income tax liabilities</b>							
As at January 1, 2014	(6,951)	-	(1,792)	-	(98,573)	(1,465)	(108,781)
Credit/(Charged) to income statement	5,967	-	925	-	(23,995)	(622)	(17,725)
Exchange differences	(61)	-	(60)	-	-	(8)	(129)
As at December 31, 2014	(1,045)	-	(927)	-	(122,568)	(2,095)	(126,635)
As at January 1, 2015	(1,045)	-	(927)	-	(122,568)	(2,095)	(126,635)
Credit/(Charged) to income statement	325	-	(480)	-	(20,496)	(394)	(21,045)
Credit to other comprehensive income	-	-	517	-	-	-	517
Exchange differences	(31)	-	(41)	-	-	(20)	(92)
As at December 31, 2015	(751)	-	(931)	-	(143,064)	(2,509)	(147,255)

## NOTES TO THE CONSOLIDATED FINANCIAL STATEMENTS

**9 DEFERRED INCOME TAXES** (Continued)

Deferred income tax assets are recognised for tax loss carry-forwards and deductible temporary differences to the extent that the realisation of the related tax benefit through future taxable profits is probable. Deferred income tax assets being calculated at applicable tax rates have not been recognised in respect of the following as management believes it is more likely than not that they would not be utilised before expiration:

	As at December 31,	
	2015 US\$'000	2014 US\$'000
Tax losses and credits	10,786	13,162
Deductible temporary differences	1,023	2,736
	<b>11,809</b>	<b>15,898</b>

As at December 31, 2015, the Group has US\$13,784,000 (December 31, 2014: US\$13,784,000) of gross net operating loss ('NOL') carry forwards in the US subject to certain annual utilisation limitations which will begin to expire in 2032. As at December 31, 2015, the Group has US\$35,757,000 (December 31, 2014: US\$42,531,000) of non-US gross NOL carry forwards which have various expiration dates of which a significant amount is unlimited.

As at December 31, 2015, the Group has utilised all of its available tax credits (comprised of foreign tax credits and research and development tax credits). At December 31, 2014, the Group had US\$6,041,000 of various tax credits that would have begun to expire in 2022. With the exception of these credits, the remaining deductible temporary differences do not expire under current tax legislation.

Deferred income tax liabilities have not been recognised for the withholding tax and other taxes that would be payable on the unremitted earnings of certain subsidiaries because the Company is able to control the timing of reversal of the temporary differences and no material amounts of such unremitted earnings are currently intended to be distributed. Unremitted earnings totaled US\$463,824,000 as at December 31, 2015 (December 31, 2014: US\$285,479,000).

**10 DERIVATIVE FINANCIAL INSTRUMENTS**

	As at December 31,			
	2015		2014	
	Assets US\$'000	Liabilities US\$'000	Assets US\$'000	Liabilities US\$'000
Forward foreign exchange contracts	659	5,872	–	3,971
Interest rate swap – cash flow hedge	–	6	–	56
	<b>659</b>	<b>5,878</b>	–	<b>4,027</b>
Less: non-current portion:				
Forward foreign exchange contracts	–	–	–	(487)
Interest rate swaps – cash flow hedge	–	–	–	(56)
Current portion	<b>659</b>	<b>5,878</b>	–	<b>3,484</b>

## NOTES TO THE CONSOLIDATED FINANCIAL STATEMENTS

**10 DERIVATIVE FINANCIAL INSTRUMENTS** (Continued)**(a) Forward foreign exchange contracts**

The notional principal amount of the outstanding forward foreign exchange contracts at December 31, 2015 were US\$127,872,000 (December 31, 2014: US\$64,800,000).

**(b) Interest rate swap**

The notional principal amount of the outstanding interest rate swap contract at December 31, 2015 was US\$30,125,000 (December 31, 2014: US\$48,615,000).

At December 31, 2015, the fixed interest rate is 0.45% (December 31, 2014: 0.45%), and the floating rate is 1-Month LIBOR (December 31, 2014: 1-Month LIBOR). Gains and losses recognised in the hedging reserve in equity on the interest rate swap contract as at December 31, 2015 will be continuously released to the income statement until February 2016.

**11 INVENTORIES**

	<b>As at December 31,</b>	
	<b>2015</b>	2014
	<b>US\$'000</b>	US\$'000
Raw materials	160,777	154,984
Work in progress	36,110	43,359
Finished goods	75,371	42,813
	<b>272,258</b>	241,156
Less: provision for impairment losses	(18,316)	(15,107)
	<b>253,942</b>	226,049

The cost of inventories recognised as an expense and included in cost of sales for the year ended December 31, 2015 amounted to US\$2,615,576,000 (2014: US\$2,379,644,000).

The carrying amounts of inventories pledged as collateral were US\$149,431,000 as at December 31, 2015 (December 31, 2014: US\$142,764,000).

**12 TRADE RECEIVABLES**

	<b>As at December 31,</b>	
	<b>2015</b>	2014
	<b>US\$'000</b>	US\$'000
Trade receivables, gross	571,379	527,848
Less: provision for impairment	(1,401)	(2,623)
	<b>569,978</b>	525,225

## NOTES TO THE CONSOLIDATED FINANCIAL STATEMENTS

**12 TRADE RECEIVABLES** (Continued)

Credit terms range primarily from 30–90 days after the invoice date depending on the customer and the geographical region. Ageing analysis of trade receivables based on invoice date is as follows:

	<b>As at December 31,</b>	
	<b>2015</b>	2014
	<b>US\$'000</b>	US\$'000
0 to 30 days	261,526	271,782
31 to 60 days	220,182	185,993
61 to 90 days	51,467	44,896
Over 90 days	38,204	25,177
	<b>571,379</b>	<b>527,848</b>

Trade receivables of US\$34,831,000 were past due but not impaired as at December 31, 2015 (December 31, 2014: US\$35,939,000). These relate mainly to a number of customers for whom there is no history of default. The ageing analysis of these past due but not impaired receivables is as follows:

	<b>As at December 31,</b>	
	<b>2015</b>	2014
	<b>US\$'000</b>	US\$'000
Overdue up to 30 days	21,872	26,182
Overdue 30 to 60 days	9,010	8,512
Overdue 60 to 90 days	2,425	1,245
Overdue over 90 days	1,524	–
	<b>34,831</b>	<b>35,939</b>

The provision for impairment of receivables includes estimates and assessments of individual receivables based on the creditworthiness of the respective customer, current economic developments, and the analysis of historical losses on receivables. The creditworthiness of a customer is assessed on their payment history and ability to make repayments and customer credit rating from third party rating agencies.

Trade receivables of US\$1,401,000 were impaired as at December 31, 2015 on which full provision was made (2014: US\$2,623,000). These individually impaired receivables are relatively long overdue.

Movement on the provision for impairment of trade receivables is as follows:

	<b>For the year ended</b>	
	<b>December 31,</b>	
	<b>2015</b>	2014
	<b>US\$'000</b>	US\$'000
<b>As at January 1</b>	2,623	2,904
Reversal of provision	(1,097)	(125)
Exchange differences	(125)	(156)
<b>As at December 31</b>	<b>1,401</b>	<b>2,623</b>

The carrying amounts of trade receivables pledged as collateral were US\$294,981,000 as at December 31, 2015 (December 31, 2014: US\$268,768,000).

## NOTES TO THE CONSOLIDATED FINANCIAL STATEMENTS

**13 OTHER RECEIVABLES AND PREPAYMENTS**

	<b>As at December 31,</b>	
	<b>2015</b>	2014
	<b>US\$'000</b>	US\$'000
Amounts reimbursable from customers on tools	42,451	45,195
Other taxes recoverable (i)	30,597	25,762
Prepaid assets	21,425	21,225
Reimbursable engineering expenses	2,932	8,683
Deposits to vendors	3,164	2,433
Others	61	403
	<b>100,630</b>	103,701
Less: non-current portion	<b>(6,107)</b>	(10,410)
Current portion	<b>94,523</b>	93,291

Note:

- (i) Balance mainly represents value-added tax recoverable and certain incentives granted to the Group for investing capital and maintaining jobs in the State of Michigan, USA.

**14 RESTRICTED BANK DEPOSITS**

As at December 31, 2015, restricted bank deposits of US\$148,000 (December 31, 2014: US\$772,000) are maintained with banks for issuance of letters of credit and pledges of bank borrowings.

**15 CASH AND CASH EQUIVALENTS**

The Group's RMB balances of US\$86,724,000 are deposited with banks in China as at December 31, 2015 (December 31, 2014: US\$20,397,000). The RMB is not a freely convertible currency. The conversion of these RMB denominated balances into foreign currencies in China is subject to rules and regulations of foreign exchange control promulgated by the China government. Cash balances denominated in RMB will be used as part of the normal operating activities in China and are classified as unrestricted cash on this basis.



## NOTES TO THE CONSOLIDATED FINANCIAL STATEMENTS

## 16 RESERVES

	Share premium US\$'000	Merger Reserve US\$'000	Share-based compensation reserve US\$'000	Exchange reserve US\$'000	Hedging reserve US\$'000	Total other reserves US\$'000
As at January 1, 2014	252,643	113,000	–	(3,844)	–	361,799
Dividends paid to shareholders	(21,654)	–	–	–	–	(21,654)
Value of employee services provided under share-option scheme (note 25(a))	–	–	1,240	–	–	1,240
Exchange differences	–	–	–	(23,215)	–	(23,215)
Cash flow hedge	–	–	–	–	(56)	(56)
<b>As at December 31, 2014</b>	<b>230,989</b>	<b>113,000</b>	<b>1,240</b>	<b>(27,059)</b>	<b>(56)</b>	<b>318,114</b>
Dividends paid to shareholders	(32,395)	–	–	–	–	(32,395)
Value of employee services provided under share-option scheme (note 25(a))	–	–	2,725	–	–	2,725
Exercise of options	257	–	–	–	–	257
Exchange differences	–	–	–	(32,292)	–	(32,292)
Cash flow hedge	–	–	–	–	(834)	(834)
<b>As at December 31, 2015</b>	<b>198,851</b>	<b>113,000</b>	<b>3,965</b>	<b>(59,351)</b>	<b>(890)</b>	<b>255,575</b>

(i) *Share premium*

Share premium of the Group represents the difference between the fair value of shares issued and their respective par value. Incremental costs directly attributable to the issue of new shares are shown in share premium as a deduction.

A dividend of US\$32,395,000 relating to the Group's year ended December 31, 2014 earnings was paid during the year ended December 31, 2015 (year ended December 31, 2014: US\$21,654,000).

(ii) *Merger reserve*

The Company was incorporated on August 21, 2012 and the Group's reorganisation was completed on January 30, 2013. The merger reserve in the consolidated balance sheets at December 31, 2015 and 2014 represent the aggregate amount of share capital of PCM US and PCM Singapore.

(iii) *Hedging reserve*

The hedging reserve comprises the effective portion of the accumulative net change in the fair value of hedging instruments used in cash flow hedges pending subsequent recognition in profit or loss as the hedged cash flows affect profit or loss.

(iv) *Exchange reserve*

Exchange reserve arises from currency translations of all group entities that have a functional currency different from the US dollar being translated into the Group's presentation currency of US dollar.

## NOTES TO THE CONSOLIDATED FINANCIAL STATEMENTS

## 17 BORROWINGS

	<b>As at December 31,</b>	
	<b>2015</b>	2014
	<b>US\$'000</b>	US\$'000
<b>Non-current</b>		
Borrowings from banks		
– secured (note (1.a))	71,475	71,275
– unsecured (note (1.b))	241,367	317,374
Notes (note (1.e))	246,507	245,051
Finance lease obligations (note (1.f))	1,190	312
	<b>560,539</b>	<b>634,012</b>
<b>Current</b>		
Borrowings from banks		
– secured, others (note (1.c))	1,260	7,284
– unsecured (note (1.d))	4,622	13,575
Add: current portion of:		
– non-current secured borrowings (note (1.a))	14,744	11,002
– non-current unsecured borrowings (note (1.b))	59,857	64,725
– finance lease obligations (note (1.f))	701	384
	<b>81,184</b>	<b>96,970</b>
<b>Total borrowings</b>	<b>641,723</b>	<b>730,982</b>

## (1) Note:

(a) This primarily includes:

- (i) Long-term borrowings of US\$66,072,000 (December 31, 2014: US\$54,779,000) which bears interest at LIBOR plus 1.75%–2.25% per annum and matures in 2019. Secured by property, plant and equipment, trade receivables, and inventories.
- (ii) Long-term borrowings of US\$20,147,000 (December 31, 2014: 26,885,000) which bears interest at EURIBOR plus 3.1% and matures in 2020. Secured by property, plant and equipment, and inventories.

(b) This primarily includes:

- (i) Bank loans totaling US\$304,000,000 as at December 31, 2015 (December 31, 2014: US\$365,000,000), which are guaranteed by AVIC and Beijing E-Town International Investment & Development Co., Ltd., (shareholder of Pacific Century Motors, Inc. which is the intermediate holding company of the Company), bear interest at LIBOR plus 3.5% per annum and due in semi-annual installments of US\$30,500,000 which commenced in June 2014 and mature in October 2020 with the last repayment to be made then.
- (ii) Bank loans of US\$nil as at December 31, 2015 (December 31, 2014: US\$19,583,000) bearing interest at LIBOR plus 2.75%–5.60% per annum.

## NOTES TO THE CONSOLIDATED FINANCIAL STATEMENTS

## 17 BORROWINGS (Continued)

## (1) Note: (Continued)

(c) This primarily includes:

(i) A revolving line of credit of US\$nil (December 31, 2014: US\$6,377,000) borrowed by a subsidiary of the Group which bear interest at LIBOR plus 1.50%–prime plus 1.75% per annum, and is secured by property, plant and equipment, trade receivables and inventories.

(ii) A revolving line of credit of US\$1,260,000 (December 31, 2014: US\$908,000) borrowed by a subsidiary of the Group which bears interest at the Reserve Bank of India Base Rate +2.4% per annum, and is secured by property, plant and equipment, trade receivables and inventories.

(d) This primarily includes:

(i) Bank loans of US\$nil (December 31, 2014: US\$13,575,000) borrowed by a subsidiary of the Group which bear interest at LIBOR plus 1.50%–2.55% per annum.

(ii) Short-term bank loan of US\$4,622,000 (December 31, 2014: US\$ nil) borrowed by a subsidiary of the Group which bears interest at PBOC Benchmark Rate.

(e) This primarily includes notes of US\$250,000,000 in aggregate principal amount of 5.875% senior unsecured notes maturing on November 15, 2021.

(f) Finance lease obligations

(i) Gross finance leases liabilities – minimum lease payments:

	As at December 31,	
	2015	2014
	US\$'000	US\$'000
Within 1 year	879	415
Between 1 and 2 years	610	287
Between 2 and 5 years	749	30
	2,238	732
Less: future finance charges	(347)	(36)
	1,891	696

(ii) Present value of finance lease obligations:

	As at December 31,	
	2015	2014
	US\$'000	US\$'000
Within 1 year	701	384
Between 1 and 2 years	514	283
Between 2 and 5 years	676	29
	1,891	696

## NOTES TO THE CONSOLIDATED FINANCIAL STATEMENTS

**17 BORROWINGS** (Continued)**(2) Maturity of borrowings**

	As at December 31,	
	2015 US\$'000	2014 US\$'000
Within 1 year	81,184	96,970
Between 1 and 2 years	75,115	74,233
Between 2 and 5 years	236,051	252,733
Over 5 years	249,373	307,046
	<b>641,723</b>	<b>730,982</b>

**(3)** The carrying amount and fair value of non-current borrowings are as follows:

	As at December 31,			
	Carrying Amount		Fair Value	
	2015 US\$'000	2014 US\$'000	2015 US\$'000	2014 US\$'000
Bank borrowings	312,842	388,649	307,720	392,923
Other borrowings	246,507	245,051	251,014	245,051
Finance lease obligations	1,190	312	1,190	312
	<b>560,539</b>	<b>634,012</b>	<b>559,924</b>	<b>638,286</b>

The fair values of bank borrowings are based on discounted cash flows using applicable discount rates based upon the prevailing market rates of interest available to the Group for financial instruments with substantially the same terms and characteristic as at the balance sheet dates. Such discount rates ranged from 3.04% to 3.37% as at December 31, 2015 (2014: 1.71% to 3.17%), depending on the type of the debt, and were within level 2 of the fair value hierarchy.

The fair values of other borrowings are based on quoted prices in active markets, and were within level 1 of the fair value hierarchy.

The carrying amounts of current borrowings approximate their fair value.

**(4) Weighted average annual interest rates**

	As at December 31,	
	2015	2014
Bank borrowings	4.4%	4.3%
Notes	5.9%	5.9%

## NOTES TO THE CONSOLIDATED FINANCIAL STATEMENTS

**17 BORROWINGS** (Continued)**(5) Currency denomination**

	As at December 31,	
	2015 US\$'000	2014 US\$'000
US\$	615,694	704,094
Euro	20,147	26,885
RMB	4,622	–
Others	1,260	3
	641,723	730,982

**18 RETIREMENT BENEFITS AND COMPENSATION**

	As at December 31,	
	2015 US\$'000	2014 US\$'000
Pension – defined benefit plans (note (a))	10,511	12,329
Extended disability benefits (note (b))	2,884	14,957
Workers' compensation (note (c))	7,098	5,431
	20,493	32,717
Less: non-current portion	(17,544)	(29,960)
Current portion	2,949	2,757

**(a) Pension – defined benefit plans**

The Group sponsors various defined benefit plans that generally provide benefits based on negotiated amounts for each year of eligible service. The Group's most significant plans are under regulatory frameworks in Mexico, Germany, France and US. The US Executive Retirement Plan ('US ERP') is a frozen plan established on December 1, 2010 as part of the acquisition of business. The plans had no curtailments or settlements affecting the defined benefit obligation.

## NOTES TO THE CONSOLIDATED FINANCIAL STATEMENTS

**18 RETIREMENT BENEFITS AND COMPENSATION** (Continued)**(a) Pension – defined benefit plans** (Continued)

The Group employs Mercer (U.S.) Inc., an independent qualified actuary, to measure pension costs using the projected unit credit method. The amounts recognised in balance sheets are determined as follows:

	For the year ended December 31, 2015			For the year ended December 31, 2014		
	Non-US plans US\$'000	US ERP US\$'000	Total US\$'000	Non-US plans US\$'000	US ERP US\$'000	Total US\$'000
Present value of funded obligations (note (i))	9,309	1,685	10,994	11,392	1,747	13,139
Fair value of plan assets (note (ii))	(483)	–	(483)	(810)	–	(810)
Deficit of funded plans	8,826	1,685	10,511	10,582	1,747	12,329

There is no current requirement for the Group to fund the deficit between the fair value of plan assets and the present value of the defined benefit plan obligations as at December 31, 2015.

(i) Movement in the present value of defined benefit obligations:

	For the year ended December 31, 2015			For the year ended December 31, 2014		
	Non-US plans US\$'000	US ERP US\$'000	Total US\$'000	Non-US plans US\$'000	US ERP US\$'000	Total US\$'000
Opening balance	11,392	1,747	13,139	11,502	1,629	13,131
Current service cost	630	–	630	769	–	769
Past service (income)/cost (1)	(74)	–	(74)	(1,955)	–	(1,955)
Interest cost	482	51	533	646	59	705
(Gains)/losses from changes in financial assumptions	(1,040)	(16)	(1,056)	1,912	71	1,983
Experience (gains)/losses	(181)	(58)	(239)	572	(2)	570
Losses/(gains) from changes in demographic assumptions	23	–	23	–	(1)	(1)
Exchange differences	(1,197)	–	(1,197)	(1,434)	–	(1,434)
Benefits paid	(726)	(39)	(765)	(620)	(9)	(629)
Ending balance	9,309	1,685	10,994	11,392	1,747	13,139

(1) Past service (income)/costs relate to non-US plan amendments which resulted in a change to plan membership.

## NOTES TO THE CONSOLIDATED FINANCIAL STATEMENTS

**18 RETIREMENT BENEFITS AND COMPENSATION** (Continued)**(a) Pension – defined benefit plans** (Continued)

(ii) Movement in the fair value of plan assets:

	For the year ended December 31, 2015			For the year ended December 31, 2014		
	Non-US plans US\$'000	US ERP US\$'000	Total US\$'000	Non-US plans US\$'000	US ERP US\$'000	Total US\$'000
Opening balance	(810)	–	(810)	(892)	–	(892)
Interest Income	(45)	–	(45)	(60)	–	(60)
Return on plan assets, excluding amounts included in interest income	29	–	29	39	–	39
Employer contributions	(486)	(39)	(525)	(620)	(9)	(629)
Exchange differences	103	–	103	103	–	103
Benefits paid	726	39	765	620	9	629
Ending balance	(483)	–	(483)	(810)	–	(810)

Plan assets comprise as follows:

	As at December 31,	
	2015	2014
Equities	36%	36%
Bonds	32%	32%
Cash	32%	32%
	100%	100%

Amounts recognised in other comprehensive income:

	For the year ended December 31, 2015		For the year ended December 31, 2014	
	Non-US plans US\$'000	US ERP US\$'000	Non-US plans US\$'000	US ERP US\$'000
Gains/(losses) from changes in financial assumptions	1,040	16	(1,912)	(71)
Experience gains/(losses)	181	58	(572)	2
(Losses)/gains from changes in demographic assumptions	(23)	–	–	1
Return on plan assets, excluding amounts included in interest income	(29)	–	(39)	–
Total	1,169	74	(2,523)	(68)



## NOTES TO THE CONSOLIDATED FINANCIAL STATEMENTS

**18 RETIREMENT BENEFITS AND COMPENSATION** (Continued)**(a) Pension – defined benefit plans** (Continued)

Amount recognised in income statement:

	For the year ended December 31, 2015			For the year ended December 31, 2014		
	Non-US plans US\$'000	US ERP US\$'000	Total US\$'000	Non-US plans US\$'000	US ERP US\$'000	Total US\$'000
Current service cost	630	–	630	769	–	769
Past service (income)/cost	(74)	–	(74)	(1,955)	–	(1,955)
Interest cost	437	51	488	586	59	645
<b>Total</b>	<b>993</b>	<b>51</b>	<b>1,044</b>	<b>(600)</b>	<b>59</b>	<b>(541)</b>
<i>Included in:</i>						
Cost of sales	717	–	717	(394)	–	(394)
Engineering and product development costs	72	–	72	(296)	–	(296)
Selling and distribution costs	7	–	7	7	–	7
Administrative expenses	197	51	248	83	59	142
	<b>993</b>	<b>51</b>	<b>1,044</b>	<b>(600)</b>	<b>59</b>	<b>(541)</b>

Principal actuarial assumptions used were as follows:

	December 31, 2015		December 31, 2014	
	Non-US plans	US ERP	Non-US plans	US ERP
Discount rate	5.28%	3.11%	4.71%	2.92%
Salary increase rate	3.50%	NA	3.59%	NA
Price inflation rate	3.14%	NA	3.09%	NA
Pension increase rate	1.75%	NA	1.75%	NA

## NOTES TO THE CONSOLIDATED FINANCIAL STATEMENTS

**18 RETIREMENT BENEFITS AND COMPENSATION** (Continued)**(a) Pension – defined benefit plans** (Continued)

Balances of pension obligations derived from changes in the discount rate and salary increase rate at the respective year ends were as follows:

	December 31, 2015			December 31, 2014		
	Non-US plans US\$'000	US ERP US\$'000	Total US\$'000	Non-US plans US\$'000	US ERP US\$'000	Total US\$'000
1% increase in discount rate	8,361	1,607	9,968	10,037	1,651	11,688
1% decrease in discount rate	10,489	1,770	12,259	13,008	1,851	14,859
1% increase in salary increase rate	10,031	NA	10,031	12,328	NA	12,328
1% decrease in salary increase rate	8,674	NA	8,674	10,536	NA	10,536

The above sensitivity analyses are based on a change in an assumption while holding all other assumptions constant. In practice, this is unlikely to occur, and changes in some of the assumptions may be correlated. When calculating the sensitivity of the defined benefit obligation the same actuarial method has been applied in arriving at the pension liability recognised in the balance sheet.

**(b) Extended disability benefits**

Costs associated with extended disability benefits provided to injured employees in the US are accrued throughout the duration of active employment. Workforce demographic data and historical experience are utilised to develop projections of time frames and related expenses for these post-employment benefits. During 2015, certain plan amendments reducing future benefits for union participants were adopted that reduced past and future service costs.

**(c) Workers' compensation**

The Group is self-insured up to a certain amount of workers' compensation claims for hourly workforce and accrues estimated costs for filed claims based upon an actuarially determined estimate. Workers' compensation liability includes benefits related to medical, dental and vision benefits.

**19 PROVISIONS**

	As at December 31, 2015			As at December 31, 2014		
	Current US\$'000	Non- current US\$'000	Total US\$'000	Current US\$'000	Non- current US\$'000	Total US\$'000
Restructuring	727	–	727	791	–	791
Litigation (note (a))	62	215	277	642	–	642
Environmental liabilities (note (b))	150	12,081	12,231	244	12,096	12,340
Warranties (note (c))	22,832	45,071	67,903	24,336	35,268	59,604
Decommissioning (note (d))	–	7,318	7,318	–	7,094	7,094
Other	–	1,270	1,270	–	–	–
	23,771	65,955	89,726	26,013	54,458	80,471

## NOTES TO THE CONSOLIDATED FINANCIAL STATEMENTS

**19 PROVISIONS** (Continued)

Movement of provisions is as follows:

	Restructuring US\$'000	Litigation (note (a)) US\$'000	Environmental liabilities (note (b)) US\$'000	Warranties (note (c)) US\$'000	Decom- missioning (note (d)) US\$'000	Other US\$'000	Total US\$'000
<b>As at January 1, 2014</b>	1,089	824	12,408	40,403	6,193	-	60,917
(Reversals)/additions	(253)	163	85	37,178	989	-	38,162
Payments	(45)	(289)	(149)	(15,774)	-	-	(16,257)
Exchange differences	-	(56)	(4)	(2,203)	(88)	-	(2,351)
<b>As at December 31, 2014</b>	791	642	12,340	59,604	7,094	-	80,471
<b>As at January 1, 2015</b>	791	642	12,340	59,604	7,094	-	80,471
(Reversals)/additions	(64)	(142)	-	25,650	312	1,270	27,026
Payments	-	(207)	(113)	(16,446)	-	-	(16,766)
Exchange differences	-	(16)	4	(905)	(88)	-	(1,005)
<b>As at December 31, 2015</b>	727	277	12,231	67,903	7,318	1,270	89,726

Note:

## (a) Litigation

The balance represents a provision primarily for certain labour claims brought against the Group. Management is of the view that, after taking appropriate legal advice, the outcome of these legal claims will not give rise to significant losses beyond the amounts provided at each reporting date.

## (b) Environmental liabilities

A provision is recognised for remediation costs to be incurred for the restoration of the manufacturing sites upon the initial recognition of the related assets.

## (c) Warranty

A provision is recognised for warranty costs associated with products sold to the customer principally at the time of sale or when it is determined that such obligations are probable and can be reasonably estimated.

The Group recognised US\$4,100,000 during the year ended December 31, 2015 related to a potential customer product recall event that was previously disclosed in the annual financial statements for the year ended December 31, 2014 as a subsequent event.

## (d) Decommissioning

This represents asset retirement obligations at certain of the Group's manufacturing sites.

## NOTES TO THE CONSOLIDATED FINANCIAL STATEMENTS

**20 DEFERRED REVENUE**

The Group periodically receives upfront consideration from customers in connection with engineering, prototyping, and pre-production program-specific activities. These revenue amounts are deferred and recognised over the life of the related program, which typically ranges between four and seven years. The carrying amount of deferred revenue is as follows:

	As at December 31, 2015			As at December 31, 2014		
	Current US\$'000	Non- current US\$'000	Total US\$'000	Current US\$'000	Non- current US\$'000	Total US\$'000
Pre-production activity	24,710	92,416	117,126	22,253	82,452	104,705

Movement of deferred revenue is as follows:

	As at December 31, 2015 US\$'000	2014 US\$'000
<b>As at January 1</b>	104,705	78,662
Additions	36,198	43,195
Amortisation	(23,289)	(17,075)
Reversals	(335)	–
Exchange differences	(153)	(77)
<b>As at December 31</b>	117,126	104,705

**21 TRADE PAYABLES**

The ageing analysis of trade payables based on invoice date is as follows:

	As at December 31, 2015 US\$'000	2014 US\$'000
0–30 days	313,247	277,002
31–60 days	193,339	115,149
61–90 days	32,328	28,837
91–120 days	13,532	10,944
Over 121 days	6,323	7,043
	558,769	438,975

## NOTES TO THE CONSOLIDATED FINANCIAL STATEMENTS

**22 OTHER PAYABLES AND ACCRUALS**

	For the year ended	
	December 31, 2015	2014
	US\$'000	US\$'000
Accrued expenses	92,746	75,101
Deposits from customers	6,157	5,837
Other taxes payable	5,221	3,880
Others	612	431
	104,736	85,249
Less: non-current portion	(7,174)	(7,908)
Current portion	97,562	77,341

**23 OTHER LOSSES, NET**

	For the year ended	
	December 31, 2015	2014
	US\$'000	US\$'000
Foreign exchange losses	6,642	201
Loss on disposal of property, plant and equipment	2,453	678
Fair value losses on derivative financial instruments (note 10)	6,686	4,433
Others	1,668	275
	17,449	5,587

## NOTES TO THE CONSOLIDATED FINANCIAL STATEMENTS

## 24 EXPENSE BY NATURE

	For the year ended	
	December 31,	
	2015	2014
	US\$'000	US\$'000
Raw materials used	1,923,006	1,724,202
Changes in inventories of finished goods and work-in-progress	25,309	6,827
Employee benefit costs (note 25)	489,473	449,902
Temporary labour costs	64,194	75,343
Restructuring costs (note 19)	(64)	(253)
Supplies and tools	166,329	153,176
Depreciation on property, plant and equipment (note 6)	88,837	80,258
Amortisation on		
– land use rights (note 7)	25	25
– intangible assets (note 8)	53,418	38,538
Impairment charges/(reversal of provisions) on		
– inventories	3,209	3,897
– receivables (note 12)	(1,222)	(125)
Utilities	37,682	38,270
Transportation expenses	12,916	11,357
Operating lease expenses	12,557	12,343
Warranty expenses (note 19)	25,650	37,178
Auditors' remuneration		
– audit services	2,160	2,239
– non-audit services	1,457	2,273
Others	124,997	100,135
Total cost of sales, engineering and product development costs, selling and distribution, and administrative expenses	3,029,933	2,735,585

## NOTES TO THE CONSOLIDATED FINANCIAL STATEMENTS

## 25 EMPLOYEE BENEFIT COSTS

	For the year ended	
	December 31,	
	2015	2014
	US\$'000	US\$'000
Salary expenses	374,366	331,558
Pension costs – defined contribution plans	25,090	24,654
Pension costs – defined benefit plans (note 18)	1,044	(541)
Other employee costs	88,973	94,231
	489,473	449,902

## (a) Share-based payments

Pursuant to a shareholders' resolution passed on June 5, 2014, the Company adopted a share option scheme (the 'Scheme'). The Scheme will remain in force for a period of 10 years commencing from June 5, 2014 and the period within which the option may be exercised must expire no later than 10 years from the relevant date of grant.

The subscription price for the shares under the option to be granted will be determined by the Board of Directors and will be the highest of: (a) the closing price of the shares of the Company as stated in the daily quotations sheet issued by The Stock Exchange of Hong Kong Limited on the date of grant; (b) the average closing price of the shares of the Company as stated in the daily quotations sheet issued by The Stock Exchange of Hong Kong Limited for the five business days immediately preceding the date of grant; and (c) the nominal value of the shares of the Company.

The options will be vested and become exercisable gradually after the grantees complete a period of service of 1 to 3 years from the date of grant, and subject to the Group achieving its performance targets.

On June 11, 2014, the Board approved an initial grant of share options under the Scheme, pursuant to which options to subscribe for 11,236,860 shares, representing approximately 0.4499% of the issued share capital of the Company as at the date of grant, were granted to 15 selected participants at the exercise price of HK\$5.15 per share.

On June 10, 2015, the Board approved a second grant of share options under the Scheme, pursuant to which options to subscribe for 10,358,990 shares, representing approximately 0.415% of the issued share capital of the Company as at the date of grant, were granted to 13 selected participants at the exercise price of HK\$8.61 per share.



## NOTES TO THE CONSOLIDATED FINANCIAL STATEMENTS

**25 EMPLOYEE BENEFIT COSTS** (Continued)**(a) Share-based payments** (Continued)

Movements in the number of share options outstanding and their average exercise prices are as follows:

	Average exercise price (per share) HK\$	Outstanding options (thousands)
As at January 1, 2014	–	–
Granted	5.15	11,237
Forfeited	5.15	(702)
As at December 31, 2014	5.15	10,535
Exercisable as at December 31, 2014	–	–
<b>As at January 1, 2015</b>	<b>5.15</b>	<b>10,535</b>
<b>Granted</b>	<b>8.61</b>	<b>10,359</b>
<b>Exercised</b>	<b>5.15</b>	<b>(673)</b>
<b>Forfeited</b>	<b>7.03</b>	<b>(3,716)</b>
<b>As at December 31, 2015</b>	<b>6.90</b>	<b>16,505</b>
<b>Exercisable as at December 31, 2015</b>	<b>5.15</b>	<b>2,721</b>

Share options outstanding and not yet exercisable at the end of the period have the following vesting dates and exercise prices:

	Average exercise price (per share) HK\$	Outstanding options (thousands)
June 10, 2016	8.61	2,780
June 11, 2016	5.15	2,722
June 10, 2017	8.61	2,780
June 11, 2017	5.15	2,722
June 10, 2018	8.61	2,780

The weighted average fair value of options granted during the period determined using a binomial valuation model was HK\$3.92 per option. The significant inputs into the model were share price at the measurement date of HK\$8.61, exercise price of HK\$8.61, volatility of 39%, dividend yield of nil, an expected term of 8.08 years, and an annual risk-free interest rate of 1.63%. The volatility measured at the standard deviation of continuously compounded share returns is based on statistical analysis of historical daily trading prices of the Company's shares since the date of listing (October 7, 2013) as well as the daily trading prices of benchmarked publicly traded companies in the same industry. Considering there is limited information on the historical share price of the Company, the Group referred to benchmarked companies' historical share price in addition to our share price history to determine the historical volatility.

The fair value of the share options charged to the consolidated income statement was US\$2,725,000 for the year ended December 31, 2015 (year ended December 31, 2014: US\$1,240,000).

## NOTES TO THE CONSOLIDATED FINANCIAL STATEMENTS

**25 EMPLOYEE BENEFIT COSTS** (Continued)**(b) Directors' emoluments**

The remuneration of each director for the year ended December 31, 2015 is set out below:

Name	Fees (note (ix)) US\$'000	Salary US\$'000	Discretionary bonus (note (ii)) US\$'000	Other benefits (note (iii)) US\$'000	Total US\$'000
Mr. Guibin Zhao*(i)	200	–	534	–	734
Mr. Yi Fan (i)	–	220	429	52	701
Mr. Michael Paul Richardson (i)	–	760	210	165	1,135
Mr. Hing Lun Tsang	44	–	–	–	44
Mr. Kevin Cheng Wei	44	–	–	–	44
Mr. Jianjun Liu	44	–	–	–	44
Mr. Daen Lu	30	–	113	–	143
Mr. Xiaobo Wang	30	–	113	–	143
	392	980	1,399	217	2,988

The remuneration of each director for the year ended December 31, 2014 is set out below:

Name	Fees (note (ix)) US\$'000	Salary US\$'000	Discretionary bonus (note (ii)) US\$'000	Other benefits (note (iii)) US\$'000	Total US\$'000
Mr. Guibin Zhao*(i)	200	–	376	–	576
Mr. Yi Fan (i)	–	220	286	66	572
Mr. Michael Paul Richardson (i)	–	760	210	135	1,105
Mr. Hing Lun Tsang	32	–	–	–	32
Mr. Kevin Cheng Wei	32	–	–	–	32
Mr. Jianjun Liu	32	–	–	–	32
Mr. Daen Lu	30	–	41	–	71
Mr. Xiaobo Wang	30	–	41	–	71
	356	980	954	201	2,491

\* Chief Executive of the Company

Notes:

- (i) Individual is a member of senior management.
- (ii) Discretionary bonus comprises the annual incentive compensation plan which is payable within one year from the year end, and the deferred incentive compensation plans to be settled when all the conditions are met and with approval by the board of directors (certain of which with estimates based upon the extent of meeting certain performance targets). The amount of deferred incentive compensation includes share-based payments of the share option scheme which is calculated and disclosed in accordance with the method set out in Note 25(a). These disclosed values deviate from the intrinsic value because the Company used the binomial model to calculate the fair value of the options granted on June 10, 2015 amounting to HK\$3.92 per option. When the actual share price is lower than the exercise price of HK\$8.61 per share, the options are out-of-money and the holders will not be benefitted by exercising the options.
- (iii) Other benefits include payments made for dental, disability and healthcare coverage; contributions to social security and health-saving accounts; and other non-monetary benefits.
- (iv) During the year ended December 31, 2015, no retirement benefits by a defined benefit pension plan operated by the Group were paid or made, directly or indirectly, to or receivable by a director in respect of his services as a director or other services in connection with the management of the affairs of the Company or its subsidiaries (2014: Nil).
- (v) During the year ended December 31, 2015, no payments or benefits in respect of termination of director's services were paid or made, directly or indirectly, to or receivable by a director; nor are any payable (2014: Nil).
- (vi) During the year ended December 31, 2015, no consideration was provided to or receivable by third parties for making available director's services (2014: Nil).
- (vii) There are no loans, quasi-loans or other dealings in favour of the director, his controlled bodies corporate and connected entities (2014: Nil).
- (viii) No significant transactions, arrangements and contracts in relation to the Group's business to which the Company or any of its subsidiaries was a party and in which a director of the Company had a material interest, whether directly or indirectly, subsisted at the end of the year or at any time during the year (2014: Nil).
- (ix) Fees paid are in respect to service as a director, other emoluments are in respect of other services in connection with management of the Company or its subsidiaries.

## NOTES TO THE CONSOLIDATED FINANCIAL STATEMENTS

**25 EMPLOYEE BENEFIT COSTS** (Continued)**(c) Five highest paid individuals**

The five individuals whose emoluments were the highest in the Group for the year ended December 31, 2015 include one director (2014: one), whose emoluments are reflected in the analysis presented above. The emoluments payable to the remaining four (2014: four) individuals during the year are as follows:

	<b>For the year ended December 31,</b>	
	<b>2015</b>	2014
	<b>US\$'000</b>	US\$'000
Salaries and allowances	1,422	1,560
Discretionary bonuses	4,227	4,213
Other benefits	449	345
	<b>6,098</b>	<b>6,118</b>

The emoluments of the remaining individuals fell within the following bands:

	<b>For the year ended December 31,</b>	
	<b>2015</b>	2014
	<b>Number of individuals</b>	
HK\$5,000,000 – HK\$5,500,000 (US\$645,000 – US\$710,000)	–	1
HK\$5,500,000 – HK\$6,000,000 (US\$710,000 – US\$774,000)	1	1
HK\$6,500,000 – HK\$7,000,000 (US\$839,000 – US\$903,000)	1	–
HK\$7,000,000 – HK\$7,500,000 (US\$903,000 – US\$968,000)	1	–
HK\$11,500,000 – HK\$12,000,000 (US\$1,484,000 – US\$1,548,000)	–	1
HK\$24,000,000 – HK\$24,500,000 (US\$3,096,000 – US\$3,161,000)	–	1
HK\$27,000,000 – HK\$27,500,000 (US\$3,483,000 – US\$3,548,000)	1	–

## NOTES TO THE CONSOLIDATED FINANCIAL STATEMENTS

## 26 FINANCE COSTS, NET

	For the year ended December 31,	
	2015 US\$'000	2014 US\$'000
<b>Finance income</b>		
Interest on bank deposits	2,253	1,912
<b>Finance costs</b>		
Interest expense on bank borrowings	17,436	24,494
Interest on notes	14,769	1,836
	32,205	26,330
Interest on finance leases	75	60
Realised losses on interest rate swap	808	56
Other finance costs	5,635	1,709
	38,723	28,155
Less: amount capitalised in qualifying assets (notes 6 and 8)	(5,519)	(4,660)
	33,204	23,495
Finance costs, net	30,951	21,583

## NOTES TO THE CONSOLIDATED FINANCIAL STATEMENTS

## 27 INCOME TAX EXPENSE

	For the year ended December 31,	
	2015 US\$'000	2014 US\$'000
Current income tax	49,167	48,024
Deferred income tax (note 9)	24,049	3,315
	<b>73,216</b>	<b>51,339</b>

Taxation on the Group's profits has been calculated on the estimated assessable profits for the years at the statutory rates of 35%, 25% and 19% in US, China and Poland, respectively, from where the Group's profits were mainly generated.

The tax on the Group's profit before tax differs from the theoretical amount that would arise using the weighted average tax rate applicable to profits of the combined entities as follows:

	For the year ended December 31,	
	2015 US\$'000	2014 US\$'000
Profit before income tax	283,364	214,596
Tax calculated at rates applicable to profits in respective countries	91,175	63,440
Expenses not deductible for tax purposes	3,411	4,589
Non-taxable income	(18,252)	(7,042)
Tax credits (note (i))	(7,649)	(6,881)
Preferential rates due to tax holidays (note (ii))	(8,559)	(9,423)
Tax losses and deductible temporary differences for which no deferred tax was recognised	6,283	3,454
US state and withholding taxes	5,110	3,604
Others	1,697	(402)
Tax charge	<b>73,216</b>	<b>51,339</b>

Note:

- (i) Mainly represents U.S. production incentives and research credits.
- (ii) Derived mainly from profits subject to preferential tax rate in China for high-technology enterprises and income tax exemption up to 2026 for the Group's investment in Special Economic Zones in Poland according to the relevant Polish tax rules.

## NOTES TO THE CONSOLIDATED FINANCIAL STATEMENTS

**28 EARNINGS PER SHARE****(a) Basic**

Basic earnings per share is calculated by dividing the profit attributable to equity holders of the Company by the weighted average number of ordinary shares in issue during the year.

	<b>For the year ended December 31,</b>	
	<b>2015</b>	2014
Profit attributable to the equity holders of the Company (US\$'000)	205,432	161,398
Weighted average number of ordinary shares in issue (thousands)	2,497,875	2,497,804
Basic earnings per share (in US\$)	0.08	0.06

**(b) Diluted**

Diluted earnings per share is calculated by adjusting the weighted average number of ordinary shares outstanding to assume conversion of all dilutive potential ordinary shares. The Company's dilutive potential ordinary shares comprise shares issued under the share option scheme that are vested as at December 31, 2015. The number of shares that would have been issued assuming the exercise of the share options less the number of shares that could have been issued at fair value (determined as the average market price per share for the year) for the same total proceeds is the number of shares issued for no consideration. The resulting number of shares issued for no consideration is included in the weighted average number of ordinary shares within the denominator for calculating diluted earnings per share. For the year ended December 31, 2015, the details are within the table below. For the year ended December 31, 2014, diluted earnings per share is the same as basic earnings per share because all of the Company's potential ordinary shares are antidilutive.

	<b>For the year ended December 31,</b>	
	<b>2015</b>	2014
Profit attributable to equity holders of the Company, used to determine diluted earnings per share (US\$'000)	205,432	161,398
Weighted average number of ordinary shares in issue (thousands)	2,497,875	2,497,804
Adjustment for share options (thousands)	2,547	-
Weighted average number of ordinary shares in issue for calculating diluted earnings per share (thousands)	2,500,422	2,497,804
Diluted earnings per share (in US\$)	0.08	0.06

## NOTES TO THE CONSOLIDATED FINANCIAL STATEMENTS

## 29 DIVIDENDS

	For the year ended December 31,	
	2015 US\$'000	2014 US\$'000
Final dividend, proposed of US\$0.016 (2014: US\$0.013) per share	41,086	32,280

This final dividend was proposed by the directors at a meeting held on the date of approval of these financial statements, which is not reflected as a dividend payable in these financial statements. The dividend would be paid out of the share premium account of the Company for the year ending December 31, 2016.

## 30 CONSOLIDATED STATEMENTS OF CASH FLOWS

## (a) Cash generated from operations

	For the year ended December 31,	
	2015 US\$'000	2014 US\$'000
Profit before income tax	283,364	214,596
Adjustments for:		
Finance costs	33,204	23,495
Depreciation on property, plant and equipment	88,837	80,258
Amortisation on land use rights and intangible assets	53,443	38,563
Amortisation of deferred revenue	(23,289)	(17,075)
Impairment charges on inventories and receivables	1,987	3,772
Exchange differences	–	(492)
Fair value loss on derivative financial instruments	6,686	4,433
Share of (gain)/loss of a joint venture	(1,185)	717
Share-based compensation	2,725	1,240
Others	2,453	678
	448,225	350,185
Changes in working capital:		
Increase in receivables	(61,135)	(196,614)
Increase in inventories	(40,624)	(48,917)
Increase in payables and accruals	137,839	133,948
Increase in provisions	7,984	19,554
(Decrease)/Increase in retirement benefits and compensations	(10,980)	3,748
Increase in deferred revenue	35,711	43,195
Cash generated from operations	517,020	305,099

## (b) Major non-cash transactions

During the years ended December 31, 2015, the Group purchased property, plant and equipment which were recorded in payables in the amounts of US\$51,575,000 (December 31, 2014: US\$44,508,000).



## NOTES TO THE CONSOLIDATED FINANCIAL STATEMENTS

**31 COMMITMENTS****(a) Capital commitments**

The Group has capital commitments of US\$101,508,000 as at December 31, 2015 to purchase property, plant and equipment which are contracted but not provided for (December 31, 2014: US\$92,476,000).

**(b) Operating lease commitments**

The Group's future aggregate minimum lease payments under non-cancellable operating leases are as follows:

	As at December 31,	
	2015	2014
	US\$'000	US\$'000
Up to 1 year	11,953	10,798
1 to 5 years	26,657	29,385
Over 5 years	11,781	8,811
	50,391	48,994

**32 RELATED PARTY TRANSACTIONS****(a) Transactions with Yubei Steering System Co., Ltd. (Yubei Steering), an associate of AVIC**

	For the year ended	
	December 31,	2014
	2015	2014
	US\$'000	US\$'000
Purchase of goods	18,724	8,985

**(b) Transactions with a joint venture**

On August 20, 2013, Nexteer Automotive (Suzhou) Co., Ltd. (a wholly-owned indirect subsidiary of the Company) and Chongqing Changfeng Machine Company., Ltd. (a subsidiary controlled by China South Industries Group Corporation, a China state-owned enterprise) entered into an agreement, pursuant to which the parties shall establish a joint venture Chongqing Nexteer Steering Systems Co., Ltd. in China to manufacture and sell steering products. On January 22, 2014, the entity was established and legally registered as a joint venture in Chongqing. On September 12, 2014, Nexteer Automotive (Suzhou) Co., Ltd. (a wholly-owned indirect subsidiary of the Company) transferred its 50% ownership interest to Nexteer (China) Holding Co., Ltd. (a wholly-owned subsidiary of the Company). On September 10, 2015, Chongqing Changfeng Machine Company., Ltd. (a subsidiary controlled by China South Industries Group Corporation, a China state-owned enterprise) transferred its 50% ownership interest to Chongqing Jianshe Industry (Group) Co., Ltd.

As at December 31, 2015 the Group has invested US\$9,434,000 into the joint venture (December 31, 2014: US\$6,362,000). For the year ended December 31, 2015, the Group's share of gains from the joint venture amount to US\$1,185,000 (year ended December 31, 2014: share of losses US\$717,000).

## NOTES TO THE CONSOLIDATED FINANCIAL STATEMENTS

**32 RELATED PARTY TRANSACTIONS** (Continued)**(b) Transactions with a joint venture** (Continued)

The following table sets forth the transactions between the Group and its joint venture.

	<b>For the year ended December 31,</b>	
	<b>2015</b>	2014
	<b>US\$'000</b>	US\$'000
Sale of services (i)	6,295	651
Purchase of services	13,228	565

(i) Services include engineering services, rent and other fees.

**(c) Key management compensation**

The remunerations of the Chief Executive Officer, directors and other key management members were as follows:

	<b>For the year ended December 31,</b>	
	<b>2015</b>	2014
	<b>US\$'000</b>	US\$'000
Basic salaries, other allowances and benefits	4,574	4,973
Bonuses	6,488	7,122
Others	752	829
	<b>11,814</b>	<b>12,924</b>

These remunerations are determined based on the performance of individuals and market trends.

## NOTES TO THE CONSOLIDATED FINANCIAL STATEMENTS

**33 BALANCE SHEET OF THE COMPANY**

The balance sheet of the Company on a non-consolidated basis is as follows:

	<b>As at December 31,</b>	
	<b>2015</b>	2014
	<b>US\$'000</b>	US\$'000
<b>ASSETS</b>		
<b>Non-current assets</b>		
Investments in subsidiaries	658,315	632,964
Other receivables and prepayments	44,000	20,000
	<b>702,315</b>	652,964
<b>Current assets</b>		
Cash and cash equivalents	47,539	185,437
Other receivables and prepayments	220,870	172,373
	<b>268,409</b>	357,810
<b>Total assets</b>	<b>970,724</b>	1,010,774
<b>EQUITY</b>		
<b>Capital and reserves</b>		
Share capital	32,231	32,222
Other reserves	707,216	736,629
Accumulated losses	(20,752)	(8,176)
	<b>718,695</b>	760,675
<b>Non-current liabilities</b>		
Borrowings	246,507	245,051
<b>Current liabilities</b>		
Other payables and accruals	5,522	5,048
<b>Total equity and liabilities</b>	<b>970,724</b>	1,010,774

The balance sheet of the Company was approved by the board of directors on March 15, 2016 and was signed on its behalf.

\_\_\_\_\_  
Director

\_\_\_\_\_  
Director

## NOTES TO THE CONSOLIDATED FINANCIAL STATEMENTS

**33 BALANCE SHEET OF THE COMPANY** (Continued)

The movement in other reserves of the Company on a non-consolidated basis is as follows:

	Share premium US\$'000	Share-based compensation reserve US\$'000	Capital reserve US\$'000	Accumulated losses US\$'000	Total reserves US\$'000
As at January 1, 2014	252,643	–	504,400	(8,576)	748,467
Profit for the year	–	–	–	400	400
Value of employee services provided under share-option scheme (note 25(a))	–	1,240	–	–	1,240
Dividends paid to shareholders	(21,654)	–	–	–	(21,654)
As at December 31, 2014	230,989	1,240	504,400	(8,176)	728,453
Loss for the year	–	–	–	(12,576)	(12,576)
Value of employee services provided under share-option scheme (note 25(a))	–	2,725	–	–	2,725
Dividends paid to shareholders	(32,395)	–	–	–	(32,395)
Exercise of options	257	–	–	–	257
As at December 31, 2015	198,851	3,965	504,400	(20,752)	686,464

## NOTES TO THE CONSOLIDATED FINANCIAL STATEMENTS

## 34 SHARE CAPITAL

	Number of ordinary shares	Amount
<i>Issued and fully paid:</i>		
HK\$0.10 each at January 1, 2014, December 31, 2014 and January 1, 2015	2,497,804,000	HK\$249,780,400
Exercise of share options	673,040	HK\$67,304
HK\$0.10 each at December 31, 2015	2,498,477,040	HK\$249,847,704

## 35 PARTICULARS OF PRINCIPAL SUBSIDIARIES AND JOINT VENTURE

Name	Place of operation/ incorporation and date of incorporation	Issued and paid up capital	Attributable equity interest	Principal activities
<b>Subsidiaries</b>				
<i>Directly held:</i>				
Nexteer (China) Holding Co., Ltd.	China June 16, 2014	US\$30,000,000	100%	Investment holding
Nexteer UK Holding Ltd.	United Kingdom February 5, 2015	US\$104,120,152	100%	Investment holding
PCM (Singapore) Steering Holding Pte. Limited	Singapore November 4, 2010	US\$132,200,000 and SGD 1	100%	Investment holding

## NOTES TO THE CONSOLIDATED FINANCIAL STATEMENTS

## 35 PARTICULARS OF PRINCIPAL SUBSIDIARIES AND JOINT VENTURE (Continued)

Name	Place of operation/ incorporation and date of incorporation	Issued and paid up capital	Attributable equity interest	Principal activities
<i>Indirectly held:</i>				
Fidass II B.V.	Netherlands February 6, 2007	EUR 18,002	100%	Investment holding
Nexteer Automotive (Suzhou) Co., Ltd.	China January 24, 2007	US\$31,300,000	100%	Manufacturing of steering components
Nexteer Automotive Australia Pty Ltd	Australia January 23, 2008	AUD\$2,849,108	100%	Manufacturing of steering components
Nexteer Automotive Corporation	Delaware, US January 2, 2008	US\$1	100%	Manufacturing of steering components
Nexteer Automotive France SAS	France March 25, 2008	EUR 1,287,000	100%	Customer support/ engineering centre
Nexteer Automotive Germany GmbH	Germany January 2, 2008	EUR 25,000	100%	Customer support/ engineering centre
Nexteer Automotive India Private Limited	India February 25, 2008	INR 207,917,940	100%	Manufacturing of steering components
Nexteer Automotive Italy S.r.l.	Italy January 30, 2008	EUR 10,000	100%	Customer support/ engineering centre
Nexteer Automotive Japan LLC	Japan February 21, 2008	JPY 1	100%	Customer support/ engineering centre
Nexteer Automotive Korea Limited	Korea February 28, 2008	KRW 6,400,000,000	100%	Customer support/ engineering centre
Nexteer Automotive Luxembourg S.à r.l.	Luxembourg November 5, 2013	US\$20,000	100%	Investment Holding
Nexteer Automotive Mexico S. de R.L. de C.V.	Mexico June 10, 2014	MXN 129,912	100%	Distribution company
Nexteer Automotive Poland sp.zo.o.	Poland January 2, 1997	PLN 20,923,750	100%	Manufacturing of steering components

## NOTES TO THE CONSOLIDATED FINANCIAL STATEMENTS

## 35 PARTICULARS OF PRINCIPAL SUBSIDIARIES AND JOINT VENTURE (Continued)

Name	Place of operation/ incorporation and date of incorporation	Issued and paid up capital	Attributable equity interest	Principal activities
Nexteer Automotive Systems (Liuzhou) Co., Ltd.	China January 8, 2015	US\$10,000,000	100%	Manufacturing of steering components
Nexteer Industria e Comercio de Sistemas Automotivos Ltda.	Brazil February 22, 2007	BRL 198,328,316	100%	Manufacturing of steering components
Nexteer Lingyun Driveline (Wuhu) Co., Ltd.	China December 22, 2006	US\$22,400,000	60%	Manufacturing of steering components
Nexteer Lingyun Driveline (Zhuozhou) Co., Ltd.	China October 6, 1995	US\$22,000,000	60%	Manufacturing of steering components
Nexteer Luxembourg Holding IV S.à r.l.	Luxembourg March 18, 2015	US\$500,001	100%	Investment holding
Nexteer Luxembourg Holding V S.à r.l.	Luxembourg March 20, 2015	US\$100,001	100%	Investment holding
Nexteer Otomotiv Sanayi ve Ticaret Limited Sirketi	Turkey March 28, 2008	TRY 1,105,000	100%	Manufacturing of steering components
Nexteer Poland Holding sp. z o.o.	Poland December 23, 2010	PLN 3,895,126,650	100%	Investment holding
Nexteer US Holding I LLC	Delaware, US May 18, 2007	–	100%	Investment holding
PCM US Steering Holding LLC	Delaware, US March 9, 2009	–	100%	Investment holding
Rhodes Holding I S.à r.l.	Luxembourg January 15, 2008	EUR 22,500	100%	Investment holding
Rhodes Holding II S.à r.l.	Luxembourg January 15, 2008	EUR 4,331,151	100%	Investment holding
Rhodes I LLC	Michigan, US November 7, 2007	–	100%	Investment holding



## NOTES TO THE CONSOLIDATED FINANCIAL STATEMENTS

## 35 PARTICULARS OF PRINCIPAL SUBSIDIARIES AND JOINT VENTURE (Continued)

Name	Place of operation/ incorporation and date of incorporation	Issued and paid up capital	Attributable equity interest	Principal activities
Rhodes II LLC	Michigan, US November 7, 2007	–	100%	Investment holding
Steering Holding Pte. Ltd.	Singapore February 15, 2008	US\$6,400,000 and EUR 1	100%	Investment holding
Steering Solutions Corporation	Delaware, US October 29, 2007	US\$1	100%	Investment holding
Steering Solutions Expat Holding Corporation	Delaware, US January 2, 2008	US\$1	100%	Investment holding
Steering Solutions IP Holding Corporation	Delaware, US January 2, 2008	US\$1	100%	Investment holding
Steeringmex S. de R.L. de C.V.	Mexico December 14, 2007	MXN 100,292,971	100%	Manufacturing of steering components
<i>Joint venture:</i>				
Chongqing Nexteer Steering Systems Co., Ltd.	China January 22, 2014	RMB120,000,000	50%	Manufacturing of steering components

## FIVE YEARS' FINANCIAL SUMMARY

	2015 US\$'000	For the year ended December 31,			
		2014 US\$'000	2013 US\$'000	2012 US\$'000	2011 US\$'000
<b>RESULTS</b>					
Revenue	3,360,512	2,978,068	2,386,823	2,167,802	2,247,752
Profit before taxation	283,364	214,596	151,258	62,194	73,437
Income tax expense	(73,216)	(51,339)	(40,337)	(3,567)	(5,404)
Profit for the year	210,148	163,257	110,921	58,627	68,033
Attributable to:					
Owners of the Company	205,432	161,398	109,191	57,096	66,686
Non-controlling interests	4,716	1,859	1,730	1,531	1,347
	210,148	163,257	110,921	58,627	68,033
Earnings per share, USD					
Basic	0.08	0.06	0.06	0.03	0.04
Diluted	0.08	0.06	0.06	0.03	0.04
<b>ASSETS AND LIABILITIES</b>					
Total assets	2,456,822	2,221,972	1,805,189	1,258,871	973,490
Total liabilities	(1,602,457)	(1,513,953)	(1,214,443)	(1,067,062)	(850,472)
Total equity	854,365	708,019	590,746	191,809	123,018
Equity attributable to owners of the Company	827,422	683,619	567,703	170,931	110,828
Non-controlling interests	26,943	24,400	23,043	20,878	12,190
	854,365	708,019	590,746	191,809	123,018